



---

# **FS-1370DN**

# **PF-100**

# **SERVICE**

# **MANUAL**

Published in June 2010  
2L0SM062  
Rev-2

## **CAUTION**

RISK OF EXPLOSION IF BATTERY IS REPLACED BY AN INCORRECT TYPE. DISPOSE OF USED BATTERIES ACCORDING TO THE INSTRUCTIONS.

It may be illegal to dispose of this battery into the municipal waste stream. Check with your local solid waste officials for details in your area for proper disposal.

## **ATTENTION**

IL Y A UN RISQUE D'EXPLOSION SI LA BATTERIE EST REMPLACÉE PAR UN MODÈLE DE TYPE INCORRECT. METTRE AU REBUT LES BATTERIES UTILISÉES SELON LES INSTRUCTIONS DONNÉES.

Il peut être illégal de jeter les batteries dans des eaux d'égout municipales. Vérifiez avec les fonctionnaires municipaux de votre région pour les détails concernant des déchets solides et une mise au rebut appropriée.

## Revision history

Revision	Date	Replaced pages	Remarks
1	April 23, 2010	1-3-1, 1-3-2, 1-3-7, 1-3-10 to 1-3-14, 1-4-2, 1-4-3, 1-6-2, 1-6-6	-
2	June 3, 2010	1-3-1, 1-3-8	-

This page is intentionally left blank.

---

# Safety precautions

---

This booklet provides safety warnings and precautions for our service personnel to ensure the safety of their customers, their machines as well as themselves during maintenance activities. Service personnel are advised to read this booklet carefully to familiarize themselves with the warnings and precautions described here before engaging in maintenance activities.

## Safety warnings and precautions

Various symbols are used to protect our service personnel and customers from physical danger and to prevent damage to their property. These symbols are described below:

**⚠ DANGER:** High risk of serious bodily injury or death may result from insufficient attention to or incorrect compliance with warning messages using this symbol.

**⚠ WARNING:** Serious bodily injury or death may result from insufficient attention to or incorrect compliance with warning messages using this symbol.

**⚠ CAUTION:** Bodily injury or damage to property may result from insufficient attention to or incorrect compliance with warning messages using this symbol.

### Symbols

The triangle ( $\triangle$ ) symbol indicates a warning including danger and caution. The specific point of attention is shown inside the symbol.



General warning.



Warning of risk of electric shock.



Warning of high temperature.

⊘ indicates a prohibited action. The specific prohibition is shown inside the symbol.



General prohibited action.



Disassembly prohibited.

● indicates that action is required. The specific action required is shown inside the symbol.



General action required.





Remove the power plug from the wall outlet.











Always ground the copier.

# 1. Installation Precautions

## WARNING











- Do not use a power supply with a voltage other than that specified. Avoid multiple connections to one outlet: they may cause fire or electric shock. When using an extension cable, always check that it is adequate for the rated current. .... 
- Connect the ground wire to a suitable grounding point. Not grounding the copier may cause fire or electric shock. Connecting the earth wire to an object not approved for the purpose may cause explosion or electric shock. Never connect the ground cable to any of the following: gas pipes, lightning rods, ground cables for telephone lines and water pipes or faucets not approved by the proper authorities. .... 

## CAUTION:





- Do not place the copier on an infirm or angled surface: the copier may tip over, causing injury. .... 
- Do not install the copier in a humid or dusty place. This may cause fire or electric shock. .... 
- Do not install the copier near a radiator, heater, other heat source or near flammable material. This may cause fire. .... 
- Allow sufficient space around the copier to allow the ventilation grills to keep the machine as cool as possible. Insufficient ventilation may cause heat buildup and poor copying performance. .... 
- Always handle the machine by the correct locations when moving it. .... 
- Always use anti-toppling and locking devices on copiers so equipped. Failure to do this may cause the copier to move unexpectedly or topple, leading to injury. .... 
- Avoid inhaling toner or developer excessively. Protect the eyes. If toner or developer is accidentally ingested, drink a lot of water to dilute it in the stomach and obtain medical attention immediately. If it gets into the eyes, rinse immediately with copious amounts of water and obtain medical attention. .... 
- Advise customers that they must always follow the safety warnings and precautions in the copier's instruction handbook. .... 

## 2. Precautions for Maintenance











### WARNING

- Always remove the power plug from the wall outlet before starting machine disassembly. .... 
- Always follow the procedures for maintenance described in the service manual and other related brochures. .... 
- Under no circumstances attempt to bypass or disable safety features including safety mechanisms and protective circuits. .... 
- Always use parts having the correct specifications. .... 
- Always use the thermostat or thermal fuse specified in the service manual or other related brochure when replacing them. Using a piece of wire, for example, could lead to fire or other serious accident. .... 
- When the service manual or other serious brochure specifies a distance or gap for installation of a part, always use the correct scale and measure carefully. .... 
- Always check that the copier is correctly connected to an outlet with a ground connection. .... 
- Check that the power cable covering is free of damage. Check that the power plug is dust-free. If it is dirty, clean it to remove the risk of fire or electric shock. .... 
- Never attempt to disassemble the optical unit in machines using lasers. Leaking laser light may damage eyesight. .... 
- Handle the charger sections with care. They are charged to high potentials and may cause electric shock if handled improperly. .... 

### CAUTION

- Wear safe clothing. If wearing loose clothing or accessories such as ties, make sure they are safely secured so they will not be caught in rotating sections. .... 
- Use utmost caution when working on a powered machine. Keep away from chains and belts. .... 
- Handle the fixing section with care to avoid burns as it can be extremely hot. .... 
- Check that the fixing unit thermistor, heat and press rollers are clean. Dirt on them can cause abnormally high temperatures. .... 



- Do not remove the ozone filter, if any, from the copier except for routine replacement. .... 
- Do not pull on the AC power cord or connector wires on high-voltage components when removing them; always hold the plug itself. .... 
- Do not route the power cable where it may be stood on or trapped. If necessary, protect it with a cable cover or other appropriate item. .... 
- Treat the ends of the wire carefully when installing a new charger wire to avoid electric leaks. .... 
- Remove toner completely from electronic components. .... 
- Run wire harnesses carefully so that wires will not be trapped or damaged. .... 
- After maintenance, always check that all the parts, screws, connectors and wires that were removed, have been refitted correctly. Special attention should be paid to any forgotten connector, trapped wire and missing screws. .... 
- Check that all the caution labels that should be present on the machine according to the instruction handbook are clean and not peeling. Replace with new ones if necessary. .... 
- Handle greases and solvents with care by following the instructions below: ..... 
  - Use only a small amount of solvent at a time, being careful not to spill. Wipe spills off completely.
  - Ventilate the room well while using grease or solvents.
  - Allow applied solvents to evaporate completely before refitting the covers or turning the power switch on.
  - Always wash hands afterwards.
- Never dispose of toner or toner bottles in fire. Toner may cause sparks when exposed directly to fire in a furnace, etc. .... 
- Should smoke be seen coming from the copier, remove the power plug from the wall outlet immediately. .... 

### 3. Miscellaneous

#### WARNING

- Never attempt to heat the drum or expose it to any organic solvents such as alcohol, other than the specified refiner; it may generate toxic gas. .... 

This page is intentionally left blank.

# CONTENTS

<b>1-1 Specifications</b>	
1-1-1 Specifications .....	1-1-1
1-1-2 Parts names .....	1-1-3
(1) Overall .....	1-1-3
(2) Operation panel .....	1-1-4
1-1-3 Machine cross section .....	1-1-5
<b>1-2 Installation</b>	
1-2-1 Installation environment .....	1-2-1
1-2-2 Unpacking .....	1-2-2
(1) Removing the tapes .....	1-2-3
1-2-3 Installing the expanded memory (option) .....	1-2-4
1-2-4 Installing the memory card (optional) .....	1-2-5
<b>1-3 Maintenance Mode</b>	
1-3-1 Service mode .....	1-3-1
(1) Executing a service item .....	1-3-1
(2) Contents of service mode items .....	1-3-2
(3) Printing an event log (EVENT LOG) .....	1-3-10
<b>1-4 Troubleshooting</b>	
1-4-1 Paper misfeed detection .....	1-4-1
(1) Paper misfeed indication .....	1-4-1
(2) Paper misfeed detection condition .....	1-4-1
1-4-2 Self-diagnostic function .....	1-4-2
(1) Self-diagnostic function .....	1-4-2
(2) Self diagnostic codes .....	1-4-3
1-4-3 Image formation problems .....	1-4-7
(1) Completely blank printout .....	1-4-8
(2) All-black printout .....	1-4-8
(3) Dropouts .....	1-4-9
(4) Black dots .....	1-4-9
(5) Black horizontal streaks .....	1-4-9
(6) Black vertical streaks .....	1-4-10
(7) Unsharpness .....	1-4-10
(8) Gray background .....	1-4-10
(9) Dirt on the top edge or back of the paper .....	1-4-11
(10) Undulated printing at the right edge (scanning start position) .....	1-4-11
1-4-4 Electric problems .....	1-4-12
1-4-5 Mechanical problems .....	1-4-14
<b>1-5 Assembly and Disassembly</b>	
1-5-1 Precautions for assembly and disassembly .....	1-5-1
(1) Precautions .....	1-5-1
(2) Drum .....	1-5-1
(3) Toner container .....	1-5-1
(4) How to tell a genuine Kyocera Mita toner container .....	1-5-2
1-5-2 Outer covers .....	1-5-3
(1) Detaching and refitting the top cover .....	1-5-3
(2) Detaching and refitting the right and left covers .....	1-5-4
1-5-3 Paper feed section .....	1-5-6
(1) Detaching and refitting the paper feed roller assembly (paper feed roller and pickup roller) .....	1-5-6
(2) Detaching and refitting the retard roller assembly .....	1-5-8
(3) Detaching and refitting the MP paper feed roller .....	1-5-10
1-5-4 Developing section .....	1-5-11
(1) Detaching and refitting the developing unit .....	1-5-11
1-5-5 Drum section .....	1-5-12
(1) Detaching and refitting the drum unit .....	1-5-12
(2) Detaching and refitting the main charger unit .....	1-5-13

1-5-6	Transfer/separation section .....	1-5-14
	(1) Detaching and refitting the transfer roller .....	1-5-14
1-5-7	Fuser section .....	1-5-16
	(1) Detaching and refitting the fuser unit.....	1-5-16
	(2) Switching the fuser pressure .....	1-5-18
1-5-8	PWBs .....	1-5-19
	(1) Detaching and refitting the control PWB .....	1-5-19
	(2) Detaching and refitting the power source PWB.....	1-5-22
	(3) Detaching and refitting the high voltage PWB.....	1-5-24
1-5-9	Others .....	1-5-28
	(1) Detaching and refitting the main motor .....	1-5-28
	(2) Detaching and refitting the laser scanner unit.....	1-5-29
	(3) Detaching and refitting the eraser lamp (PWB).....	1-5-31
	(4) Direction of installing the left cooling fan motor and right cooling fan motor .....	1-5-32
<b>1-6 Firmware</b>		
1-6-1	Downloading firmware .....	1-6-1
	(1) Firmware files .....	1-6-1
	(2) Downloading the firmware from the USB memory .....	1-6-2
	(3) Downloading the firmware from the memory card.....	1-6-4
<b>2-1 Mechanical Construction</b>		
2-1-1	Paper feed/conveying section.....	2-1-1
	(1) Cassette paper feed section.....	2-1-1
	(2) MP tray paper feed section .....	2-1-2
	(3) Paper conveying section .....	2-1-3
2-1-2	Drum section.....	2-1-4
	(1) Drum section .....	2-1-4
	(2) Main charger unit.....	2-1-5
2-1-3	Optical section .....	2-1-6
	(1) Laser scanner unit.....	2-1-6
2-1-4	Developing section.....	2-1-8
2-1-5	Transfer/separation section .....	2-1-9
2-1-6	Cleaning section .....	2-1-10
2-1-7	Fuser section .....	2-1-11
2-1-8	Paper exit section .....	2-1-13
2-1-9	Duplex/conveying section .....	2-1-15
<b>2-2 Electrical Parts Layout</b>		
2-2-1	Electrical parts layout.....	2-2-1
	(1) PWBs .....	2-2-1
	(2) Switches and sensors .....	2-2-3
	(3) Other electrical components.....	2-2-4
<b>2-3 Operation of the PWBs</b>		
2-3-1	Power source PWB.....	2-3-1
2-3-2	Control PWB .....	2-3-3
<b>2-4 Appendixes</b>		
2-4-1	Appendixes .....	2-4-1
	(1) Wiring diagram .....	2-4-1
	(2) Repetitive defects gauge.....	2-4-2
	(3) Maintenance parts list .....	2-4-3

## 1-1-1 Specifications

Type .....	Desktop
Printing method.....	Electrophotography, laser scan
Paper weight.....	Cassette: 60 to 120 g/m <sup>2</sup> (Duplex: 60 to 105 g/m <sup>2</sup> ) MP tray: 60 to 220 g/m <sup>2</sup>
Paper type .....	Cassette: Plain, Preprinted, Bond, Recycled, Rough, Letterhead, Color (Colour), Prepunched, High quality, Custom 1 to 8 MP tray: Plain, Transparency, Preprinted, Labels, Bond, Recycled, Rough, Vellum, Letterhead, Color (Colour), Prepunched, Envelope, Cardstock, Thick paper, High quality, Custom 1 to 8
Paper size.....	Cassette: A4, JIS B5, A5, Folio, Legal, Letter, Oficio II, Statement, Executive, A6, B6, ISO B5, Envelope C5, 16K, Custom (105 × 148 to 216 × 356 mm/4 1/8 × 5 13/16" to 8 1/2 × 14") MP tray: A4, JIS B5, A5, Folio, Legal, Letter, Oficio II, Statement, Executive, A6, B6, ISO B5, Envelope C5, Envelope #10, Envelope #9, Envelope #6-3/4, Envelope Monarch, Envelope DL, Hagaki, Ofuku Hagaki, 16K, Yokei 2, Yokei 4, Custom (70 × 148 to 216 × 356 mm/2 13/16 × 5 13/16" to 8 1/2 × 14")
Printing speed.....	Simplex printing: 35 ppm (A4) 37 ppm (Letter) 20 ppm (A5) Duplex printing 19 ppm (A4) 20 ppm (Letter)
First print time .....	7 seconds or less (A4, feed from cassette)
Warm-up time .....	120 V AC model: Power on 20 seconds or less (22 °C/71.6 °F, 60%RH) Sleep 15 seconds or less (22 °C/71.6 °F, 60%RH) 220 - 240 V AC model: Power on 19 seconds or less (22 °C/71.6 °F, 60%RH) Sleep 14 seconds or less (22 °C/71.6 °F, 60%RH)
Paper capacity .....	Cassette: 250 sheets (80 g/m <sup>2</sup> , A4/Letter or smaller) MP tray: 50 sheets (80 g/m <sup>2</sup> , A4/Letter or smaller)
Output tray capacity .....	Simplex printing: 250 sheets (80 g/m <sup>2</sup> ) Duplex printing: 200 sheets (80 g/m <sup>2</sup> )
Continuous printing.....	1 to 999 sheets
Photoconductor.....	OPC drum (diameter 30 mm)
Image write system.....	Semiconductor laser (1 beam)
Charging system.....	Scorotron (positive charging)
Developing system .....	Mono component dry developing method Toner replenishing: Automatic from the toner container
Transfer system .....	Transfer roller (negative-charged)
Separation system .....	Small diameter separation, discharger brush
Cleaning system .....	Drum: Counter blade
Charge erasing system.....	Exposure by eraser lamp (LED)
Fusing system.....	Heat roller system
Memory.....	Standard: 128 MB Maximum: 1152 MB
Resolution.....	Fine 1200 mode, Fast 1200 mode, 600 dpi, 300 dpi
Operating environment .....	Temperature: 10 to 32.5 °C/50 to 90.5 °F Humidity: 15 to 80% Altitude: 2,500 m/8,202 ft maximum Brightness: 1,500 lux maximum

2L0

Controller .....	PowerPC 440F5/500 MHz
Supported OS .....	Microsoft Windows 2000/XP/Vista/7, Windows Server 2003/2008, Mac OS X 10.x
Interface .....	Hi-Speed USB: × 1 Network: × 1 (10BASE-T/100BASE-TX) KUIO-W slot: × 1
PDL .....	PRESCRIBE
Dimension (W × D × H) .....	375 × 393 × 267 mm 14 3/4 × 15 1/2 × 10 1/2"
Weight (without toner container) .....	12 kg/26.5 lb
Power source .....	120 V AC, 60 Hz, 8.0 A 220 to 240 V AC, 50/60 Hz, 4.2 A
Power consumption .....	120 V AC model, Standard Maximum: 925 W During printing: 584.0 W During standby: 10.3 W (EcoFuser ON), 93.3 W (EcoFuser OFF) Sleep mode: 5.5 W 120 V AC model, Full options Maximum: 935 W During printing: 593.1 W During standby: 12.9 W (EcoFuser ON), 89.1 W (EcoFuser OFF) Sleep mode: 6.8 W 220 - 240 V AC model, Standard Maximum: 987 W During printing: 553.9 W During standby: 11.0 W (EcoFuser ON), 89.3 W (EcoFuser OFF) Sleep mode: 5.5 W 220 - 240 V AC model, Full options Maximum: 998 W During printing: 561.9 W During standby: 13.5 W (EcoFuser ON), 88.2 W (EcoFuser OFF) Sleep mode: 6.9 W
Options .....	Expanded memory, Paper feeder × 2

NOTE: These specifications are subject to change without notice.

## 1-1-2 Parts names

### (1) Overall

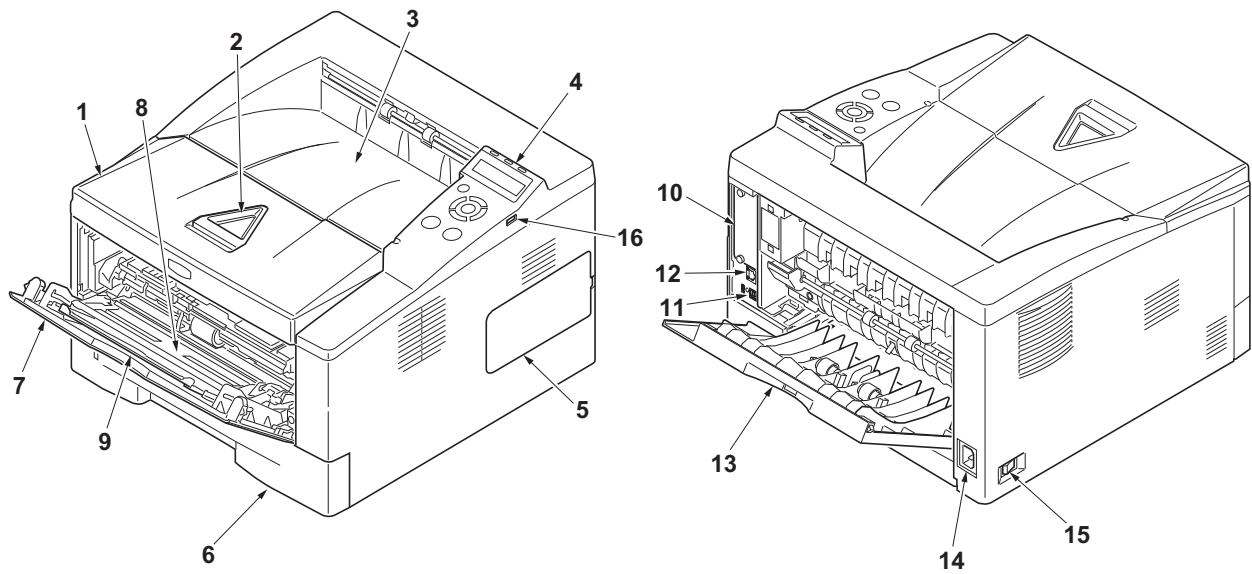

**Figure 1-1-1**

- |                     |                                   |
|---------------------|-----------------------------------|
| 1. Top cover        | 9. Sub tray                       |
| 2. Paper stopper    | 10. Optional interface slot cover |
| 3. Top tray         | 11. USB interface connector       |
| 4. Operation panel  | 12. Network interface connector   |
| 5. Right side cover | 13. Rear cover                    |
| 6. Cassette         | 14. Power cord connector          |
| 7. Front cover      | 15. Power switch                  |
| 8. MP tray          | 16. USB memory slot               |

(2) Operation panel

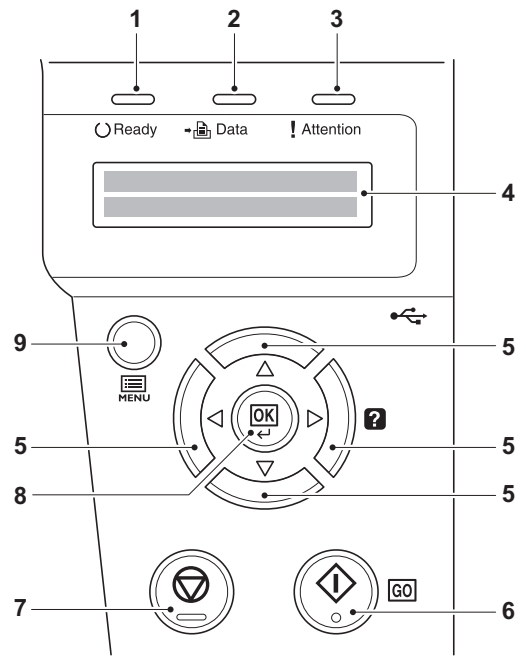

Figure 1-1-2

- 1. Ready indicator
- 2. Data indicator
- 3. Attention indicator
- 4. Message display
- 5. Cursor keys
- 6. GO key
- 7. CANCEL key
- 8. OK key
- 9. MENU key



## 1-1-3 Machine cross section

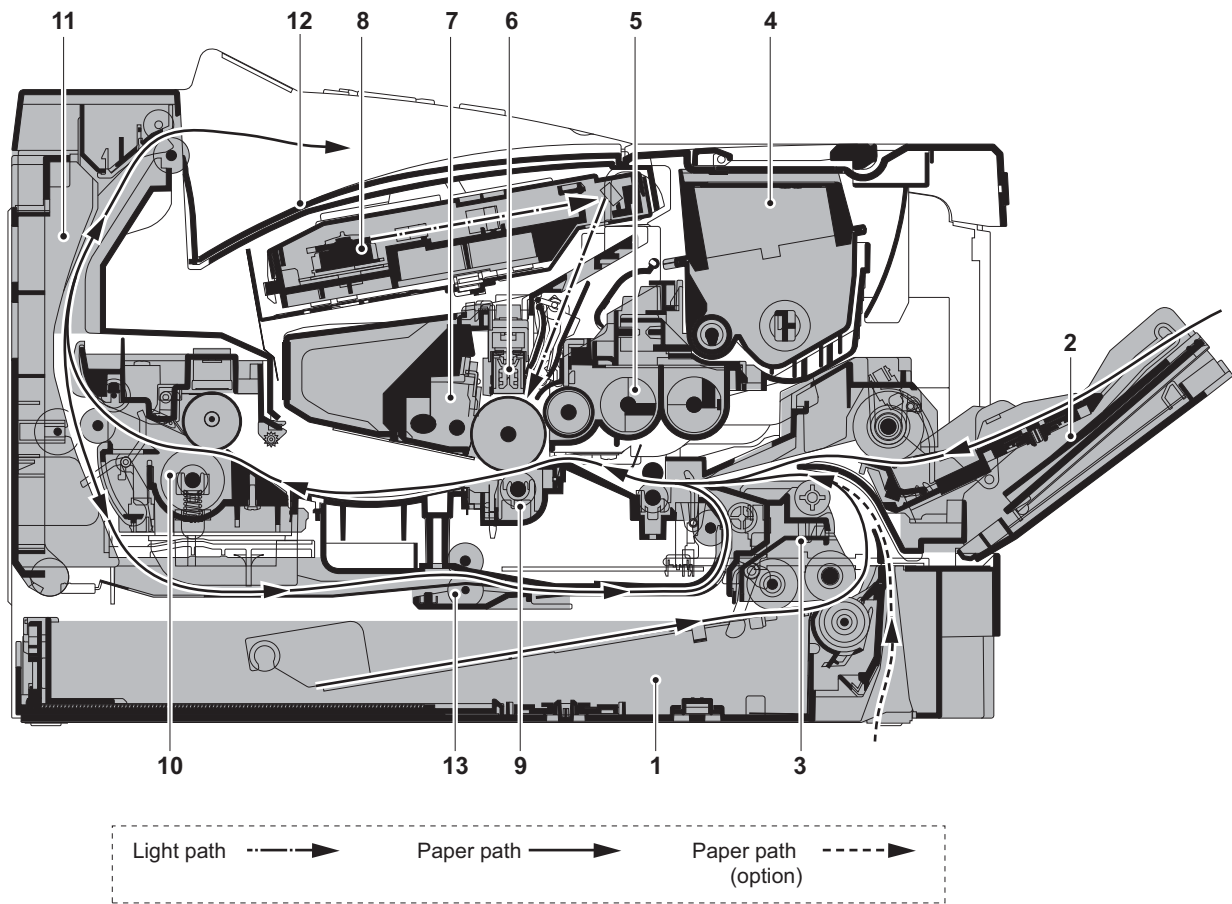

Figure 1-1-3

- |                                 |                                |
|---------------------------------|--------------------------------|
| 1. Cassette                     | 7. Drum unit                   |
| 2. MP tray                      | 8. Laser scanner unit          |
| 3. Paper feed/conveying section | 9. Transfer/separation section |
| 4. Toner container              | 10. Fuser section              |
| 5. Developing unit              | 11. Paper exit section         |
| 6. Main charger unit            | 12. Top tray                   |
|                                 | 13. Duplex/conveying section   |

This page is intentionally left blank.

### 1-2-1 Installation environment

1. Temperature: 10 to 32.5°C/50 to 90.5°F
2. Humidity: 15 to 80%RH
3. Power supply: 120 V AC, 8.0 A  
220 - 240 V AC, 4.2 A
4. Power source frequency: 50 Hz  $\pm 0.3\%$ /60 Hz  $\pm 0.3\%$
5. Installation location

Avoid direct sunlight or bright lighting. Ensure that the photoconductor will not be exposed to direct sunlight or other strong light when removing paper jams.

Avoid locations subject to high temperature and high humidity or low temperature and low humidity; an abrupt change in the environmental temperature; and cool or hot, direct air.

Avoid places subject to dust and vibrations.

Choose a surface capable of supporting the weight of the machine.

Place the machine on a level surface (maximum allowance inclination: 1°).

Avoid air-borne substances that may adversely affect the machine or degrade the photoconductor, such as mercury, acidic or alkaline vapors, inorganic gasses, NOx, SOx gases and chlorine-based organic solvents.

Select a well-ventilated location.

6. Allow sufficient access for proper operation and maintenance of the machine.

Machine front: 500 mm/19 11/16"

Machine rear: 200 mm/7 7/8"

Machine right: 300 mm/11 13/16"

Machine left: 300 mm/11 13/16"

Machine top: 200 mm/7 7/8"

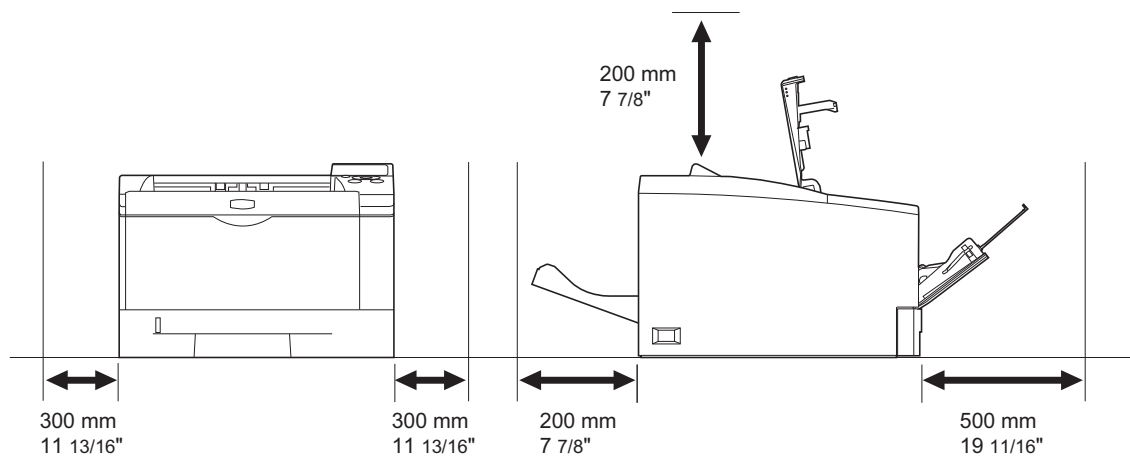

Figure 1-2-1

### 1-2-2 Unpacking

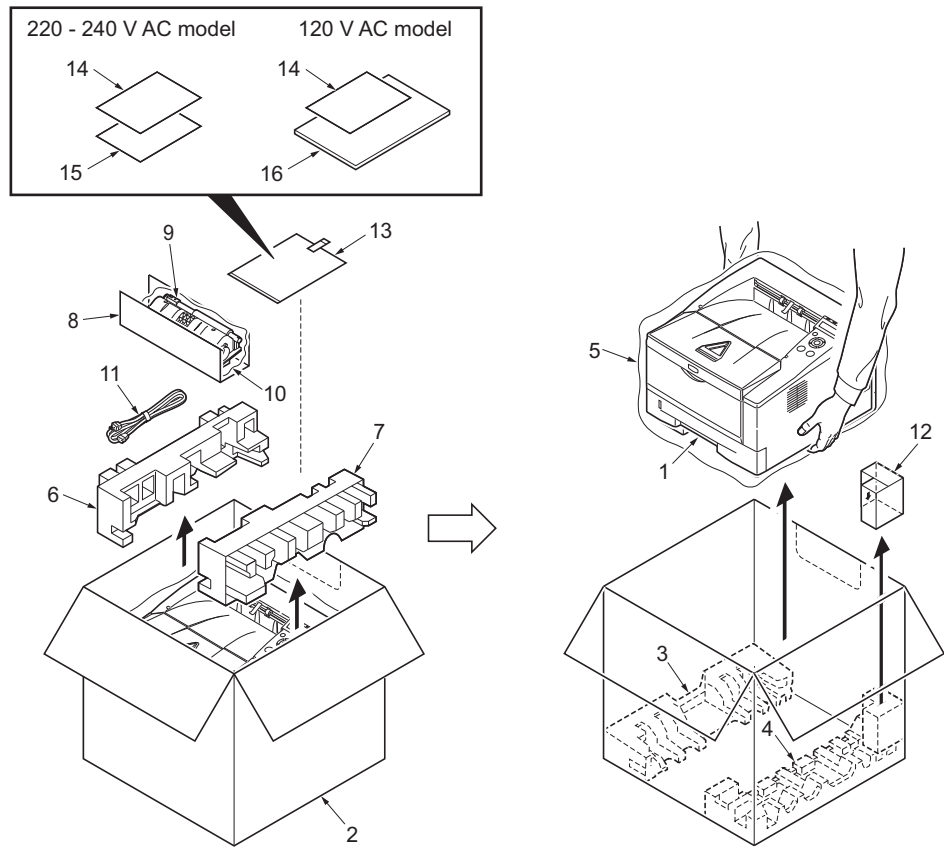
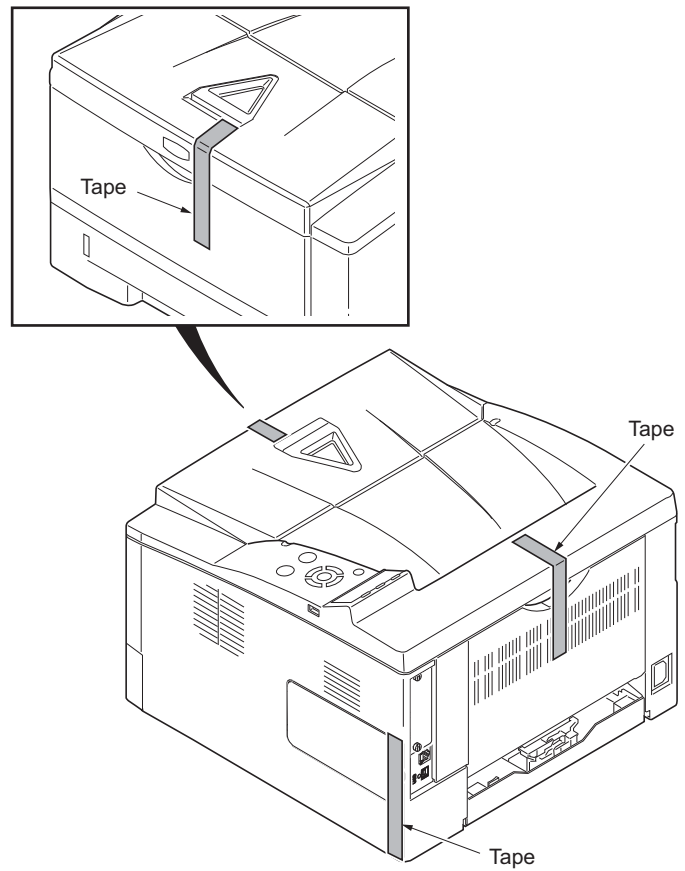

Figure 1-2-2

- |                     |                             |
|---------------------|-----------------------------|
| 1. Printer          | 9. Toner container          |
| 2. Outer case       | 10. Plastic bag             |
| 3. Bottom pad L     | 11. Power cord              |
| 4. Bottom pad R     | 12. Rear right pad          |
| 5. Machine cover    | 13. Plastic bag             |
| 6. Top pad L        | 14. Installation guide      |
| 7. Top pad R        | 15. EEA information leaflet |
| 8. Accessory spacer | 16. Operation guide         |

**(1) Removing the tapes****Procedure**

1. Remove three tapes.

**Figure 1-2-3**

### 1-2-3 Installing the expanded memory (option)

#### Procedure

1. Turn off printer power switch.  
Caution: Do not insert or remove expanded memory while printer power is on.  
Doing so may cause damage to the printer and the expanded memory.
2. Remove the right side cover.
3. Remove the tape.

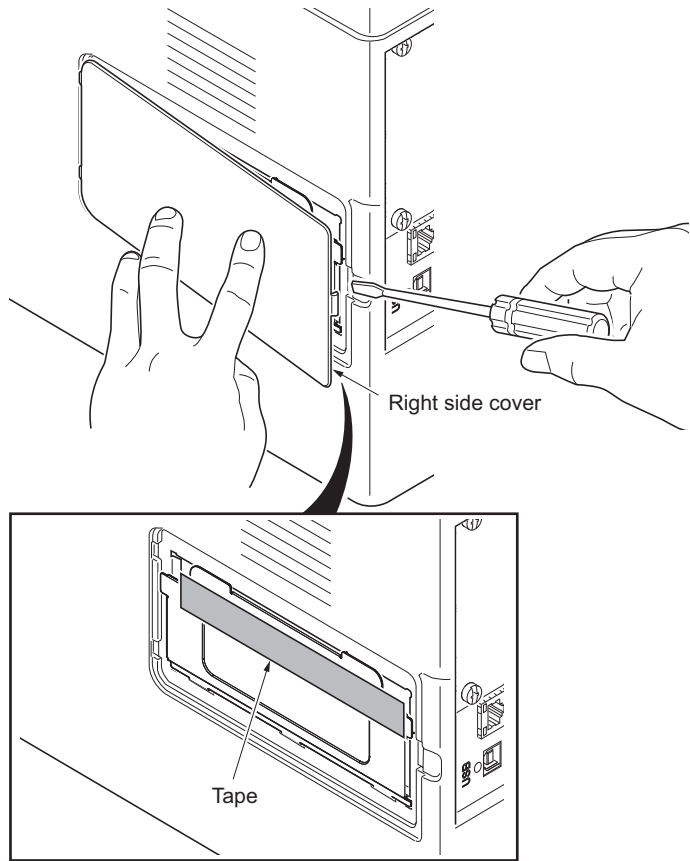

Figure 1-2-4

4. Open the memory slot cover.
  5. Insert the expanded memory into the memory socket so that the notches on the memory align with the corresponding protrusions in the slot.
  6. Close the memory slot cover.
  7. Refit the right side cover.
  8. Print a status page to check the memory expansion (See page 1-3-2).
- If memory expansion has been properly performed, information on the installed memory is printed with the total memory capacity has been increased. Standard memory capacity 128 MB.

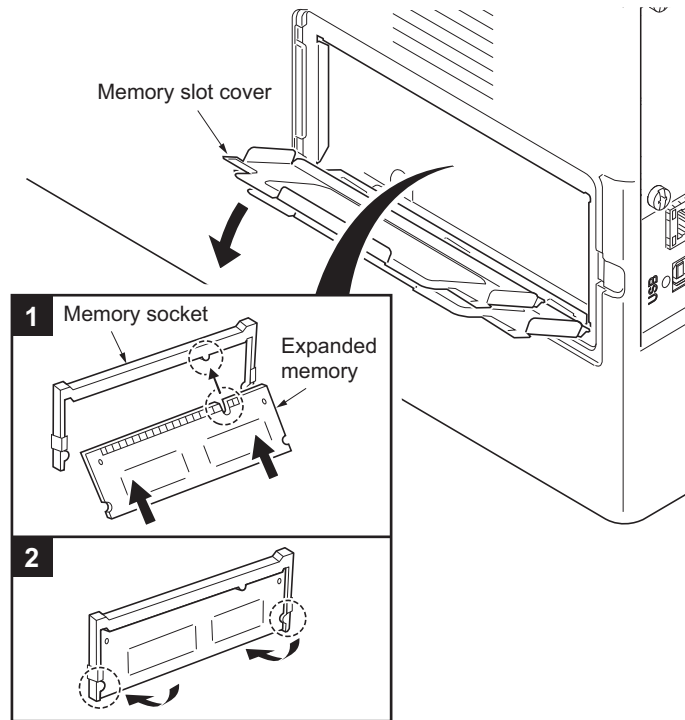

Figure 1-2-5

## 1-2-4 Installing the memory card (optional)

### Procedure

1. Turn off printer power switch.  
 Caution: Do not insert or remove memory card while printer power is on.  
 Doing so may cause damage to the printer and the memory card.
2. Open the rear cover.
3. Remove two screws and then remove the optional interface slot cover.

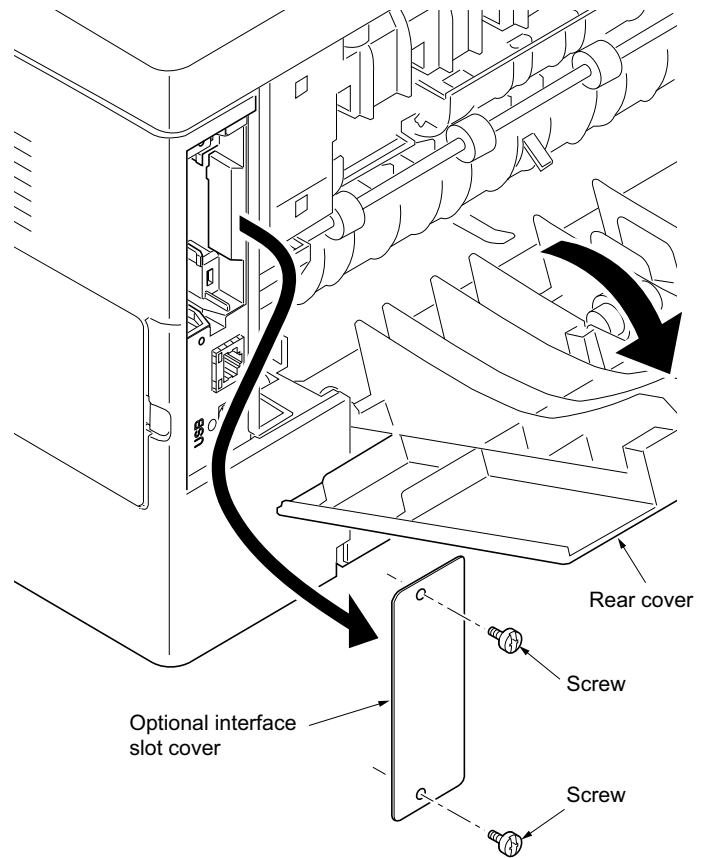

Figure 1-2-6

4. Insert the memory card into the memory card slot. Push it in all the way.
5. Secure the optional interface slot cover by using two screws.
6. Close the rear cover.
7. Format the memory card before use.

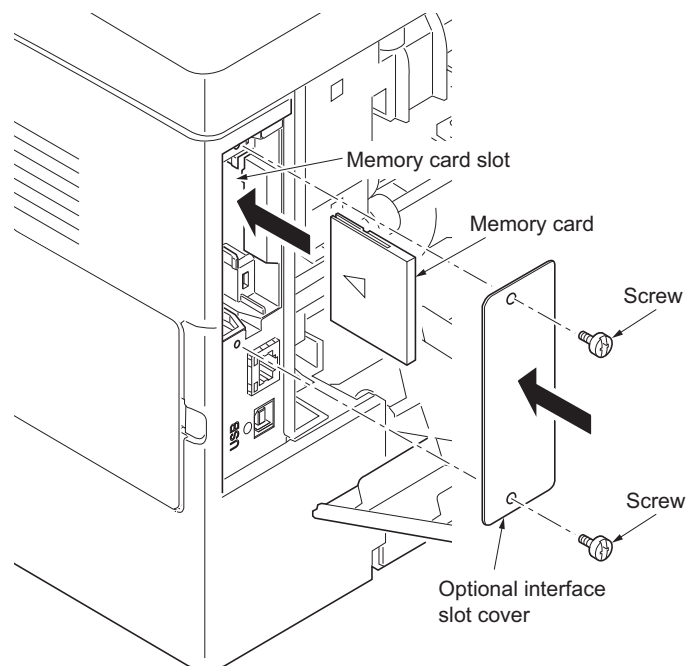

Figure 1-2-7

This page is intentionally left blank.



### 1-3-1 Service mode

The printer is equipped with a service function which can be used to maintain and service the machine.

#### (1) Executing a service item

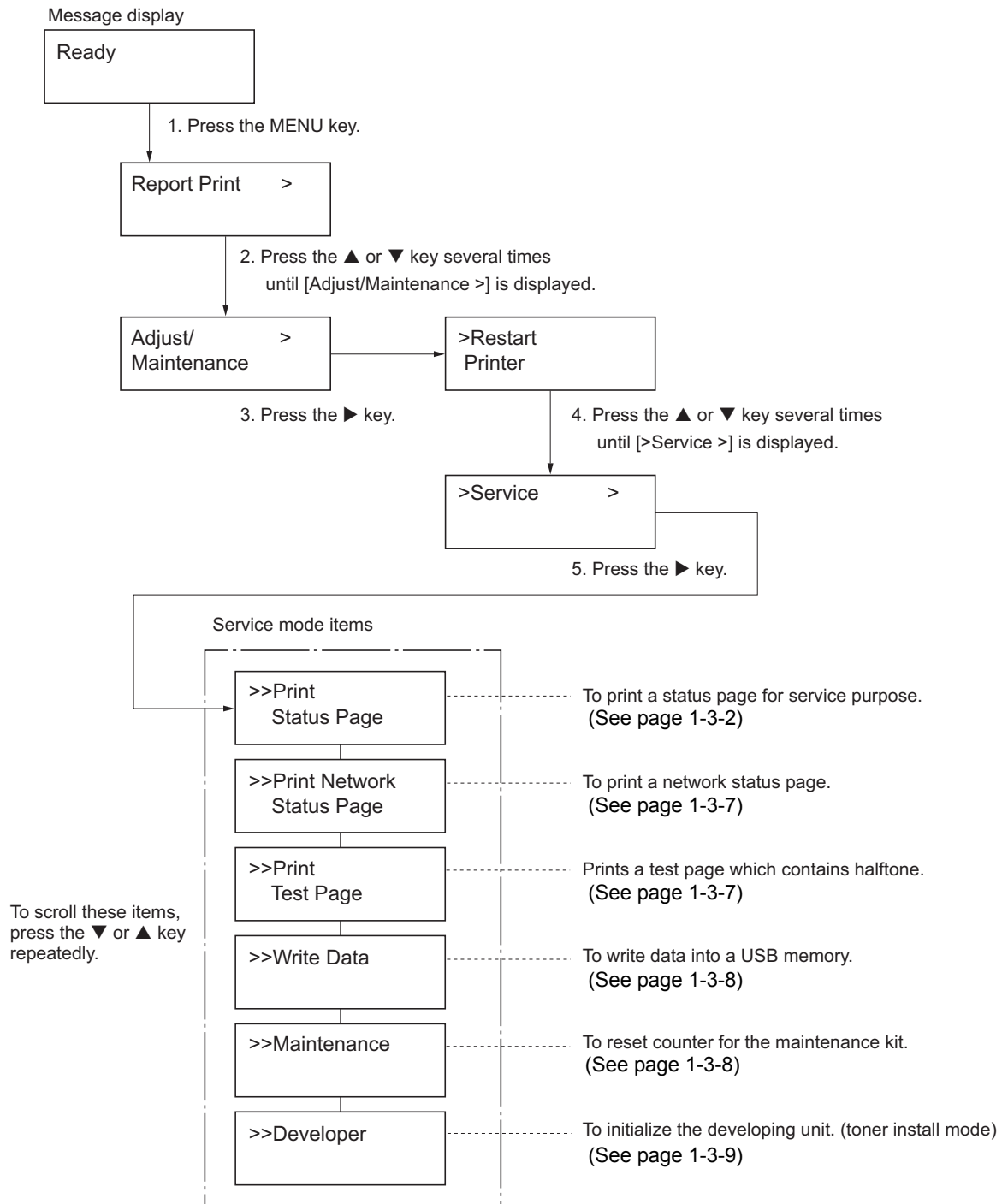

(2) Contents of service mode items

Service items	Description																																										
<div style="border: 1px solid black; padding: 5px; width: fit-content;">                     &gt;&gt;Print Status Page                 </div>	<p><b>Printing a status page for service purpose</b></p> <p><b>Description</b> Prints a status page for service purpose. The status page includes various printing settings and service cumulative.</p> <p><b>Purpose</b> To acquire the current printing environmental parameters and cumulative information.</p> <p><b>Procedure</b></p> <ol style="list-style-type: none"> <li>1. Enter the maintenance mode [&gt;&gt;Print Status Page].</li> <li>2. Press the OK key. [Print Status Page?] will be displayed.</li> <li>3. Press the OK key. [Processing] will be displayed. Two pages will be printed.</li> </ol> <p><b>Completion</b></p>																																										
	<div style="border: 1px solid black; padding: 10px;"> <h3 style="margin: 0;">Service Status Page</h3> <p style="margin: 0;">Printer</p> <div style="display: flex; justify-content: space-between; margin-top: 10px;"> <span>① Firmware version 2L0_2000.000.000</span> <span>② 2010.03.01</span> <span>③ [XXXXXXXXX][XXXXXXXXX][XXXXXXXXX][XXXXXXXXX]</span> <span>④</span> <span>⑤</span> <span>⑥</span> </div> <hr style="border: 2px solid gray; margin: 5px 0;"/> <p><b>Controller Information</b></p> <p><b>Memory Status</b></p> <table style="width: 100%; border-collapse: collapse;"> <tr> <td style="width: 30%;">⑧ Standard Size</td> <td style="width: 30%;">500.0 KB</td> <td style="width: 30%;"></td> <td style="width: 10%;"></td> </tr> <tr> <td>⑨ Option Slot</td> <td>500.0 KB</td> <td></td> <td></td> </tr> <tr> <td>⑩ Total Size</td> <td>10000.0 KB</td> <td></td> <td></td> </tr> </table> <p><b>Time</b></p> <table style="width: 100%; border-collapse: collapse;"> <tr> <td style="width: 30%;">⑪ Local Time Zone</td> <td style="width: 30%;">+01:00_Amsterdam</td> <td style="width: 30%;">e-MPS error control</td> <td style="width: 10%;">Y6</td> </tr> <tr> <td>⑫ Time Server</td> <td>10.183.53.13</td> <td></td> <td>0</td> </tr> </table> <p><b>Installed Options</b></p> <table style="width: 100%; border-collapse: collapse;"> <tr> <td style="width: 30%;">⑬ Paper feeder 2</td> <td style="width: 70%;">Installed</td> </tr> <tr> <td>⑭ Paper feeder 3</td> <td>Installed</td> </tr> <tr> <td>⑮ Memory Card</td> <td>Installed</td> </tr> </table> <p><b>Toner coverage</b> Average(%) / Usage Page(A4/Letter Conversion)</p> <table style="width: 100%; border-collapse: collapse;"> <tr> <td style="width: 30%;">⑯ K: 1.00</td> <td style="width: 70%;">/ 1111111.00</td> </tr> <tr> <td>⑰ Last Page (%)</td> <td>1.00</td> </tr> </table> <p><b>⑱ FRPO Status</b></p> <table style="width: 100%; border-collapse: collapse;"> <tr> <td style="width: 30%;">Default Pattern Switch</td> <td style="width: 30%;">B8</td> <td style="width: 30%;">0</td> <td style="width: 10%;"></td> </tr> <tr> <td>Default Font Number</td> <td>C5*10000+C2*100+C3</td> <td>00000</td> <td></td> </tr> <tr> <td colspan="4">FRPO parameters</td> </tr> </table> <div style="text-align: center; margin-top: 20px;"> <span style="font-size: 2em;">1</span> <span style="float: right;">⑦ [XXXXXXXXXXXXXXXXXXXXX]</span> </div> </div>	⑧ Standard Size	500.0 KB			⑨ Option Slot	500.0 KB			⑩ Total Size	10000.0 KB			⑪ Local Time Zone	+01:00_Amsterdam	e-MPS error control	Y6	⑫ Time Server	10.183.53.13		0	⑬ Paper feeder 2	Installed	⑭ Paper feeder 3	Installed	⑮ Memory Card	Installed	⑯ K: 1.00	/ 1111111.00	⑰ Last Page (%)	1.00	Default Pattern Switch	B8	0		Default Font Number	C5*10000+C2*100+C3	00000		FRPO parameters			
⑧ Standard Size	500.0 KB																																										
⑨ Option Slot	500.0 KB																																										
⑩ Total Size	10000.0 KB																																										
⑪ Local Time Zone	+01:00_Amsterdam	e-MPS error control	Y6																																								
⑫ Time Server	10.183.53.13		0																																								
⑬ Paper feeder 2	Installed																																										
⑭ Paper feeder 3	Installed																																										
⑮ Memory Card	Installed																																										
⑯ K: 1.00	/ 1111111.00																																										
⑰ Last Page (%)	1.00																																										
Default Pattern Switch	B8	0																																									
Default Font Number	C5*10000+C2*100+C3	00000																																									
FRPO parameters																																											

Figure 1-3-1Service status page 1

Service items	Description	
	<b>Details of service status page 1</b>	
	<b>No.</b>	<b>Items</b>
		<b>Description</b>
1	System version	-
2	System date	-
3	Engine software version	-
4	Engine software boot version	-
5	Main ROM version	-
6	Operation panel mask version	-
7	Machine serial number	-
8	Standard memory size	-
9	Option slot memory size	-
10	Total memory size	-
11	Local time zone	-
12	Time server	-
13	Optional paper feeder installing information	Paper feeder 1
14	Optional paper feeder installing information	Paper feeder 2
15	Optional memory card installing information	-
16	Page of relation to the A4/Letter	-
17	Coverage on the final output page	-
18	FRPO setting	-



Service items		Description	
<b>Details of service status page 2</b>			
No.	Items	Description	
19	NV RAM version	_ Bb 04B29 _ Bb 04B29 (a) (b) (c) (d) (e) (f)  (a) Consistency of the present software version and the database _ (underscore): OK * (Asterisk): NG (b) Database version (c) The oldest time stamp of database version (d) Consistency of the present software version and the ME firmware version _ (underscore): OK * (Asterisk): NG (e) ME firmware version (f) The oldest time stamp of the ME database version  Normal if (a) and (d) are underscored, and (b) and (e) are identical with (c) and (f).	
20	Mac address	-	
21	Destination information	-	
22	Area information	-	
23	Margin settings	0/0 (a)(b)	(a) Top margin (b) Left margin
24	Top offset for each bin	0/0/0/0/0 (a)(b)(c)(d)(e)	(a) MP tray (b) Cassette 2 (c) Cassette 3 (d) Duplex (e) Page rotation
25	Left offset for each bin	0/0/0/0/0 (a)(b)(c)(d)(e)	(a) MP tray (b) Cassette 2 (c) Cassette 3 (d) Duplex (e) Page rotation
26	L value settings	0/0/0/0/0/0/0/0 (a)(b)(c)(d)(e)(f)(g)(h)	(a) Top margin (integer) (b) Top margin (decimal place) (c) Left margin (integer) (d) Left margin (decimal place) (e) Paper length (integer) (f) Paper length (decimal place) (g) Paper width (integer) (h) Paper width (decimal place)
27	Life counter	0000000/0000000/0000000/0000000/0000000/0000000/0000000/ (a) (b) (c) (d) (e) (f) (g)  (a) Printer (b) MP tray (c) Cassette 1 (d) Cassette 2 (e) Cassette 3 (f) Duplex printing (g) Maintenance kit	

Service items		Description																						
No.	Items	Description																						
28	Operation panel lock status	0: Off 1: Partial lock 2: Full lock																						
29	USB information	0: Not connected 1: Full-Speed 2: Hi-Speed																						
30	Paper handling information	0: Paper source unit select 1: Paper source unit																						
31	Black and white printing double count mode	0: All single counts 3: Folio, Single count, Less the 330 mm (length)																						
32	Billing counting timing	-																						
33	Temperature (machine inside)	-																						
34	LXI calibration information	-																						
35	Fixed asset number	-																						
36	Job end judgment time-out time	-																						
37	Media type	Weight 0: Light 1: Normal 1 2: Normal 2 3: Normal 3 4: Heavy 1 5: Heavy 2 6: Heavy 3 7: Extra Heavy	Fuser 0: Hi 1: Middle 2: Low 3: Vellum	Duplex 0: Disable 1: Enable																				
38	SPD information	-																						
39	RFID information	-																						
40	RFID reader/writer version information	-																						
41	Toner install mode information	0: OFF 1: ON																						
42	Engine parameter information	Hexadecimal, 512 bytes																						
43	DRT table number	-																						
44	DRT parameter coefficient	-																						
45	Optional font version	-																						
46	Optional table version	-																						
47	Optional message version	-																						
48	WEB optional version	-																						
NOTE:																								
Code conversion																								
<table border="1"> <tr> <td>A</td> <td>B</td> <td>C</td> <td>D</td> <td>E</td> <td>F</td> <td>G</td> <td>H</td> <td>I</td> <td>J</td> </tr> <tr> <td>0</td> <td>1</td> <td>2</td> <td>3</td> <td>4</td> <td>5</td> <td>6</td> <td>7</td> <td>8</td> <td>9</td> </tr> </table>					A	B	C	D	E	F	G	H	I	J	0	1	2	3	4	5	6	7	8	9
A	B	C	D	E	F	G	H	I	J															
0	1	2	3	4	5	6	7	8	9															

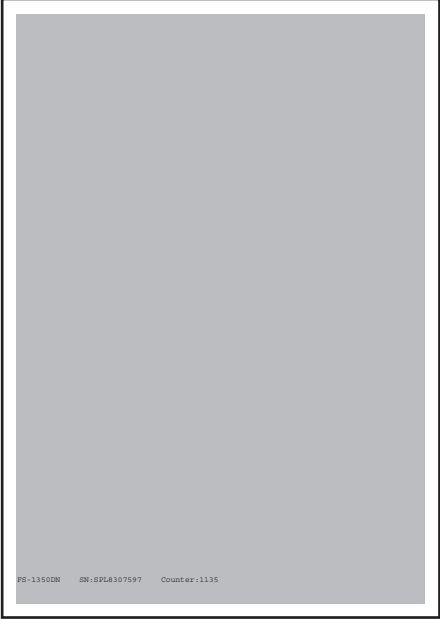
Service items	Description
<div data-bbox="172 250 435 338" style="border: 1px solid black; padding: 5px;">           &gt;&gt;Print Network Status Page         </div>	<p data-bbox="480 244 868 271"><b>Printing a status page for network</b></p> <p data-bbox="480 304 612 331"><b>Description</b></p> <p data-bbox="480 333 1310 360">On the status page for network, detailed network setting information is printed.</p> <p data-bbox="480 394 600 421"><b>Procedure</b></p> <ol data-bbox="504 423 1289 506" style="list-style-type: none"> <li>1. Enter the maintenance mode [&gt;&gt;Print Network Status Page].</li> <li>2. Press the OK key. [&gt;&gt;Print Network Status Page?] will be displayed.</li> <li>3. Press the OK key. Three sheets of network status page will be printed.</li> </ol> <p data-bbox="480 508 612 535"><b>Completion</b></p>
<div data-bbox="172 595 435 683" style="border: 1px solid black; padding: 5px;">           &gt;&gt;Print Test Page         </div>	<p data-bbox="480 589 703 616"><b>Printing a test page</b></p> <p data-bbox="480 649 612 676"><b>Description</b></p> <p data-bbox="480 678 927 705">Prints a test page which contains halftone.</p> <p data-bbox="480 707 576 734"><b>Purpose</b></p> <p data-bbox="480 736 1070 763">To check the activation of the developer and drum units.</p> <p data-bbox="480 797 600 824"><b>Procedure</b></p> <ol data-bbox="504 826 1145 909" style="list-style-type: none"> <li>1. Enter the maintenance mode [&gt;&gt;Print Test Page].</li> <li>2. Press the OK key. [&gt;&gt;Print Test Page?] will be displayed.</li> <li>3. Press the OK key. A sheet of test page will be printed.</li> </ol> <p data-bbox="480 911 612 938"><b>Completion</b></p> <div data-bbox="751 965 1193 1581" style="border: 1px solid black; text-align: center; padding: 20px;">  </div> <p data-bbox="887 1615 1023 1641" style="text-align: center;"><b>Figure 1-3-3</b></p>

Service items	Description
<div style="border: 1px solid black; padding: 5px; width: fit-content;">&gt;&gt;Write Data</div>	<p><b>Write data (USB memory data write)</b></p> <p><b>Description</b> To write data into a USB memory.</p> <p><b>Procedure</b> Install the USB memory before attempting to write data.</p> <ol style="list-style-type: none"> <li>1. Enter the maintenance mode [&gt;&gt;Write Data].</li> <li>2. Press the OK key. [&gt;&gt;Write Data?] will be displayed.</li> <li>3. Press the OK key. [Data waiting] is displayed and the printer waits for data to be written.</li> <li>4. When the data is sent, [Processing] appears and the data is written to USB memory. When data writing ends, the display returns to [Ready].</li> </ol> <p><b>Completion</b></p>
<div style="border: 1px solid black; padding: 5px; width: fit-content;">&gt;&gt;Maintenance</div>	<p><b>Counter reset for the maintenance kit</b></p> <p><b>Description</b> The "Install MK" message means that maintenance kit should be replaced at 100,000 pages of printing. The interval counter must be manually reset using this service item.</p> <p style="margin-left: 40px;">Maintenance kit MK-172 (for 120 V specifications) Maintenance kit MK-170 (for 230 V specifications) Maintenance kit MK-174 (for 240 V specifications)</p> <p>Maintenance kit includes the following units: Drum unit Developing unit</p> <p><b>Purpose</b> To reset the life counter for the developing unit and drum unit included in maintenance kit.</p> <p><b>Procedure for replacing the maintenance kit</b> Drum unit (See page 1-5-12) Developing unit (See page 1-5-11)</p> <p><b>Procedure</b></p> <ol style="list-style-type: none"> <li>1. Enter the maintenance mode [&gt;&gt;Maintenance].</li> <li>2. Press the OK key. [&gt;&gt;Maintenance?] will be displayed.</li> <li>3. Press the OK key twice. The counter for each component is reset immediately.</li> </ol> <p><b>Completion</b></p> <p>Note: Occurrences of resetting the maintenance kits are recorded on the service status page or event log in number of pages at which the maintenance kit was replaced (See page 1-3-2, 1-3-10). This may be used to determine the possibility that the counter was erroneously or unintentionally reset.</p>



Service items	Description
<div data-bbox="177 259 440 344" style="border: 1px solid black; padding: 5px; width: fit-content;">           &gt;&gt;Developer         </div>	<p data-bbox="480 244 692 271"><b>Toner install mode</b></p> <p data-bbox="480 304 612 331"><b>Description</b></p> <p data-bbox="480 333 1433 506">The new developing unit is shipped from the factory with no toner contained. The developing unit can be automatically replete with toner when a toner container is installed onto it and the printer is turned on. However, because the toner reservoir in the developing unit has a large capacity, it requires a lengthy period of time until a substantial amount of toner has been fed to get the printer ready. (A new developing unit needs approximately 260 g for triggering the sensor inside.)</p> <p data-bbox="480 508 576 535"><b>Purpose</b></p> <p data-bbox="480 537 1078 564">To execute when the developing unit has been replaced.</p> <p data-bbox="480 598 564 624"><b>Method</b></p> <ol data-bbox="501 627 1398 741" style="list-style-type: none"> <li>1. Enter the maintenance mode [&gt;&gt;Developer].</li> <li>2. Press the OK key. [&gt;&gt;Developer?] will be displayed.</li> <li>3. Press the OK key. [Ready] will be displayed.</li> <li>4. Turn off and on the printer. [Self test] [Please wait (Adding toner)] will displayed.</li> </ol> <p data-bbox="544 743 1362 826">The printer continually engages in this mode for a period of approximately 15 minutes, after which the printer reverts to the [Ready] state. [Ready] will displayed. Developing unit initialization is finished.</p> <p data-bbox="480 828 612 855"><b>Completion</b></p>

(3) Printing an event log (EVENT LOG)

Service items	Description
<p><b>Printing an event log (EVENT LOG)</b></p>	<p><b>Printing an event log (EVENT LOG)</b></p> <p><b>Description</b> Prints a history list of occurrences of paper jam, self-diagnostics, toner replacements, etc.</p> <p><b>Purpose</b> To allow machine malfunction analysis based on the frequency of paper misfeeds, self diagnostic errors and replacements.</p> <p><b>Procedure</b></p> <ol style="list-style-type: none"> <li>1. Connect the USB or network cable between printer and PC (network).</li> <li>2. Connect the power cord.</li> </ol> <div data-bbox="612 663 1302 1301" data-label="Diagram"> <p>The diagram illustrates the back panel of a printer with two interface ports. A network cable with an RJ45 connector is shown being inserted into the 'Network interface connector'. A USB cable with a standard USB-A connector is shown being inserted into the 'USB interface connector'. Arrows point from the labels to the respective connectors.</p> </div> <p style="text-align: center;"><b>Figure 1-3-4</b></p> <ol style="list-style-type: none"> <li>3. Turn printer power on. Make sure the printer is ready.</li> <li>4. Send the following PRESCRIBE command sequence from the PC to the printer.</li> </ol> <pre>!R!KCFG"ELOG";EXIT;</pre> <p><b>Note:</b> To send a PRESCRIBE command sequence to the printer, use COMMAND CENTER (the printer's embedded web) while the printer is connected to the PC via its network interface.</p> <p>A sheet of event log will be printed.</p> <p><b>Completion</b></p>

Service items	Description																																																																																																																																																																													
	<p data-bbox="432 235 662 280"><b>Detail of event log</b></p> <div data-bbox="338 291 1396 1590" style="border: 1px solid black; padding: 10px;"> <h3 data-bbox="367 313 574 358">Event Log</h3> <p data-bbox="367 358 446 392">Printer</p> <p data-bbox="367 392 1316 459"> <span data-bbox="367 392 399 425">①</span> Firmware Version 2L0_2000.000.000 2010.04.06           <span data-bbox="837 392 869 425">②</span> [XXXXXXXXXX]           <span data-bbox="965 392 997 425">③</span> [XXXXXXXXXX]           <span data-bbox="1085 392 1117 425">④</span> [XXXXXXXXXX]           <span data-bbox="1204 392 1236 425">⑤</span> [XXXXXXXXXX]         </p> <hr/> <div style="display: flex; justify-content: space-between;"> <div data-bbox="367 481 734 515"> <p><b>⑦ Paper Jam Log</b></p> <table border="1"> <thead> <tr> <th>#</th> <th>Count.</th> <th>Event Descriptions</th> </tr> </thead> <tbody> <tr><td>16</td><td>9999999</td><td>10.01.08.01.01</td></tr> <tr><td>15</td><td>8888888</td><td>10.01.08.01.02</td></tr> <tr><td>14</td><td>7777777</td><td>10.01.08.01.01</td></tr> <tr><td>13</td><td>6666666</td><td>10.01.08.01.02</td></tr> <tr><td>12</td><td>5555555</td><td>10.01.08.01.01</td></tr> <tr><td>11</td><td>4444444</td><td>10.01.08.01.02</td></tr> <tr><td>10</td><td>3333333</td><td>10.01.08.01.01</td></tr> <tr><td>9</td><td>2222222</td><td>10.01.08.01.02</td></tr> <tr><td>8</td><td>1111111</td><td>10.01.08.01.01</td></tr> <tr><td>7</td><td>999999</td><td>10.01.08.01.02</td></tr> <tr><td>6</td><td>888888</td><td>10.01.08.01.01</td></tr> <tr><td>5</td><td>777777</td><td>10.01.08.01.02</td></tr> <tr><td>4</td><td>666666</td><td>10.01.08.01.01</td></tr> <tr><td>3</td><td>555555</td><td>10.01.08.01.02</td></tr> <tr><td>2</td><td>444444</td><td>10.01.08.01.01</td></tr> <tr><td>1</td><td>1</td><td>10.01.08.01.02</td></tr> </tbody> </table> </div> <div data-bbox="925 481 1244 515"> <p><b>⑧ Service Call Log</b></p> <table border="1"> <thead> <tr> <th>#</th> <th>Count.</th> <th>Service Code</th> </tr> </thead> <tbody> <tr><td>8</td><td>1111111</td><td>00.0000</td></tr> <tr><td>7</td><td>999999</td><td>00.0000</td></tr> <tr><td>6</td><td>888888</td><td>00.0000</td></tr> <tr><td>5</td><td>777777</td><td>00.0000</td></tr> <tr><td>4</td><td>666666</td><td>00.0000</td></tr> <tr><td>3</td><td>555555</td><td>00.0000</td></tr> <tr><td>2</td><td>444444</td><td>00.0000</td></tr> <tr><td>1</td><td>1</td><td>00.0000</td></tr> </tbody> </table> </div> <div data-bbox="925 750 1276 784"> <p><b>⑨ Maintenance Log</b></p> <table border="1"> <thead> <tr> <th>#</th> <th>Count.</th> <th>Item</th> </tr> </thead> <tbody> <tr> <td></td> <td></td> <td>Log Data Nothing...</td> </tr> </tbody> </table> </div> <div data-bbox="925 974 1228 1008"> <p><b>⑩ Unknown Toner Log</b></p> <table border="1"> <thead> <tr> <th>#</th> <th>Count.</th> <th>Item</th> </tr> </thead> <tbody> <tr><td>5</td><td>1111111</td><td>00.00</td></tr> <tr><td>4</td><td>999999</td><td>00.00</td></tr> <tr><td>3</td><td>888888</td><td>00.00</td></tr> <tr><td>2</td><td>777777</td><td>00.00</td></tr> <tr><td>1</td><td>666666</td><td>00.00</td></tr> </tbody> </table> </div> </div> </div> <div style="margin-top: 20px;"> <p><b>⑪ Counter Log</b></p> <table border="1"> <tbody> <tr> <td>J00: 0</td> <td>J13: 1</td> <td>J25: 1</td> <td>C0000: 0</td> <td>C0012: 12</td> <td rowspan="2" style="vertical-align: middle;">(h) { T00: 10 M01: 20</td> </tr> <tr> <td>J01: 1</td> <td>J14: 1</td> <td>J26: 1</td> <td>C0001: 1</td> <td>C0013: 13</td> </tr> <tr> <td>J02: 11</td> <td>J15: 1</td> <td>J27: 1</td> <td>C0002: 2</td> <td>C0014: 14</td> <td></td> </tr> <tr> <td>J03: 222</td> <td>J16: 1</td> <td>J28: 1</td> <td>C0003: 3</td> <td>C0015: 15</td> <td></td> </tr> <tr> <td>J04: 1</td> <td>J17: 1</td> <td>J29: 1</td> <td>C0004: 4</td> <td>C0016: 16</td> <td></td> </tr> <tr> <td>J05: 1</td> <td>J18: 1</td> <td>J30: 1</td> <td>C0005: 5</td> <td>C0017: 17</td> <td></td> </tr> <tr> <td>J06: 1</td> <td>J19: 1</td> <td>J31: 1</td> <td>C0006: 6</td> <td>C0018: 18</td> <td></td> </tr> <tr> <td>J07: 1</td> <td>J20: 1</td> <td>J32: 1</td> <td>C0007: 7</td> <td>C0019: 19</td> <td></td> </tr> <tr> <td>J08: 1</td> <td>J21: 1</td> <td>J33: 1</td> <td>C0008: 8</td> <td>C0020: 20</td> <td></td> </tr> <tr> <td>J09: 1</td> <td>J22: 1</td> <td>J34: 1</td> <td>C0009: 9</td> <td>C0021: 21</td> <td></td> </tr> <tr> <td>J10: 1</td> <td>J23: 1</td> <td>J35: 1</td> <td>C0010: 10</td> <td>C0022: 22</td> <td></td> </tr> <tr> <td>J12: 999</td> <td>J24: 1</td> <td>J36: 1</td> <td>C0011: 11</td> <td>C0023: 23</td> <td></td> </tr> </tbody> </table> </div>	#	Count.	Event Descriptions	16	9999999	10.01.08.01.01	15	8888888	10.01.08.01.02	14	7777777	10.01.08.01.01	13	6666666	10.01.08.01.02	12	5555555	10.01.08.01.01	11	4444444	10.01.08.01.02	10	3333333	10.01.08.01.01	9	2222222	10.01.08.01.02	8	1111111	10.01.08.01.01	7	999999	10.01.08.01.02	6	888888	10.01.08.01.01	5	777777	10.01.08.01.02	4	666666	10.01.08.01.01	3	555555	10.01.08.01.02	2	444444	10.01.08.01.01	1	1	10.01.08.01.02	#	Count.	Service Code	8	1111111	00.0000	7	999999	00.0000	6	888888	00.0000	5	777777	00.0000	4	666666	00.0000	3	555555	00.0000	2	444444	00.0000	1	1	00.0000	#	Count.	Item			Log Data Nothing...	#	Count.	Item	5	1111111	00.00	4	999999	00.00	3	888888	00.00	2	777777	00.00	1	666666	00.00	J00: 0	J13: 1	J25: 1	C0000: 0	C0012: 12	(h) { T00: 10 M01: 20	J01: 1	J14: 1	J26: 1	C0001: 1	C0013: 13	J02: 11	J15: 1	J27: 1	C0002: 2	C0014: 14		J03: 222	J16: 1	J28: 1	C0003: 3	C0015: 15		J04: 1	J17: 1	J29: 1	C0004: 4	C0016: 16		J05: 1	J18: 1	J30: 1	C0005: 5	C0017: 17		J06: 1	J19: 1	J31: 1	C0006: 6	C0018: 18		J07: 1	J20: 1	J32: 1	C0007: 7	C0019: 19		J08: 1	J21: 1	J33: 1	C0008: 8	C0020: 20		J09: 1	J22: 1	J34: 1	C0009: 9	C0021: 21		J10: 1	J23: 1	J35: 1	C0010: 10	C0022: 22		J12: 999	J24: 1	J36: 1	C0011: 11	C0023: 23	
#	Count.	Event Descriptions																																																																																																																																																																												
16	9999999	10.01.08.01.01																																																																																																																																																																												
15	8888888	10.01.08.01.02																																																																																																																																																																												
14	7777777	10.01.08.01.01																																																																																																																																																																												
13	6666666	10.01.08.01.02																																																																																																																																																																												
12	5555555	10.01.08.01.01																																																																																																																																																																												
11	4444444	10.01.08.01.02																																																																																																																																																																												
10	3333333	10.01.08.01.01																																																																																																																																																																												
9	2222222	10.01.08.01.02																																																																																																																																																																												
8	1111111	10.01.08.01.01																																																																																																																																																																												
7	999999	10.01.08.01.02																																																																																																																																																																												
6	888888	10.01.08.01.01																																																																																																																																																																												
5	777777	10.01.08.01.02																																																																																																																																																																												
4	666666	10.01.08.01.01																																																																																																																																																																												
3	555555	10.01.08.01.02																																																																																																																																																																												
2	444444	10.01.08.01.01																																																																																																																																																																												
1	1	10.01.08.01.02																																																																																																																																																																												
#	Count.	Service Code																																																																																																																																																																												
8	1111111	00.0000																																																																																																																																																																												
7	999999	00.0000																																																																																																																																																																												
6	888888	00.0000																																																																																																																																																																												
5	777777	00.0000																																																																																																																																																																												
4	666666	00.0000																																																																																																																																																																												
3	555555	00.0000																																																																																																																																																																												
2	444444	00.0000																																																																																																																																																																												
1	1	00.0000																																																																																																																																																																												
#	Count.	Item																																																																																																																																																																												
		Log Data Nothing...																																																																																																																																																																												
#	Count.	Item																																																																																																																																																																												
5	1111111	00.00																																																																																																																																																																												
4	999999	00.00																																																																																																																																																																												
3	888888	00.00																																																																																																																																																																												
2	777777	00.00																																																																																																																																																																												
1	666666	00.00																																																																																																																																																																												
J00: 0	J13: 1	J25: 1	C0000: 0	C0012: 12	(h) { T00: 10 M01: 20																																																																																																																																																																									
J01: 1	J14: 1	J26: 1	C0001: 1	C0013: 13																																																																																																																																																																										
J02: 11	J15: 1	J27: 1	C0002: 2	C0014: 14																																																																																																																																																																										
J03: 222	J16: 1	J28: 1	C0003: 3	C0015: 15																																																																																																																																																																										
J04: 1	J17: 1	J29: 1	C0004: 4	C0016: 16																																																																																																																																																																										
J05: 1	J18: 1	J30: 1	C0005: 5	C0017: 17																																																																																																																																																																										
J06: 1	J19: 1	J31: 1	C0006: 6	C0018: 18																																																																																																																																																																										
J07: 1	J20: 1	J32: 1	C0007: 7	C0019: 19																																																																																																																																																																										
J08: 1	J21: 1	J33: 1	C0008: 8	C0020: 20																																																																																																																																																																										
J09: 1	J22: 1	J34: 1	C0009: 9	C0021: 21																																																																																																																																																																										
J10: 1	J23: 1	J35: 1	C0010: 10	C0022: 22																																																																																																																																																																										
J12: 999	J24: 1	J36: 1	C0011: 11	C0023: 23																																																																																																																																																																										

⑥ [XXXXXXXXXXXXXXXXXXXXX]

Figure 1-3-5 Event log

Service items		Description		
No.	Items	Description		
1	Firmware version	-		
2	Engine software version	-		
3	Engine boot version	-		
4	Main ROM version	-		
5	Panel mask version	-		
6	Machine serial number	-		
7	Paper Jam Log	#	Count.	Event
		Remembers 1 to 16 of occurrence. If the occurrence of the previous paper jam is less than 16, all of the paper jams are logged. When the occurrence exceeded 16, the oldest occurrence is removed.	The total page count at the time of the paper jam.	Log code (2 digit, hexadecimal, 5 categories)  (a) Cause of a paper jam (b) Paper source (c) Paper size (d) Paper type (e) Paper exit

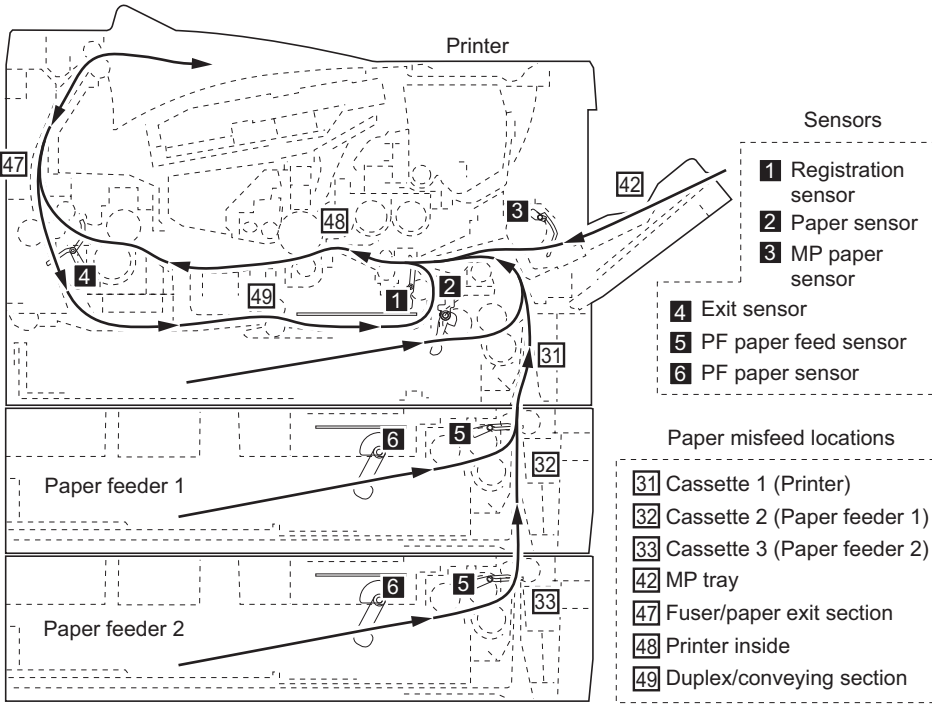
Service items		Description
7 cont.		<p>(a) Cause of paper jam</p> <p>10: Paper does not arrive at the registration sensor. [42] (MP tray)            10: Paper does not arrive at the registration sensor. [31] (Cassette 1)            10: Paper does not arrive at the registration sensor. [31] (Cassette 2)            10: Paper does not arrive at the registration sensor. [31] (Cassette 3)            10: Paper does not arrive at the registration sensor. [49] (Duplex conveying)            11: Paper does not pass the registration sensor. [48]            12: Paper remains at the registration sensor when power is turned on. [48]            20: Paper does not arrive at the exit sensor. [48]            21: Paper does not pass the exit sensor. [47]            22: Paper remains at the exit sensor when power is turned on. [47]            30: Paper does not arrive at the paper feeder 1's PF paper feed sensor. [32] (Cassette 2)            30: Paper does not arrive at the paper feeder 1's PF paper feed sensor. [33] (Cassette 3)            31: Paper does not arrive at the paper feeder 1's PF paper feed sensor. [32] (Cassette 2)            32: Paper remains at the paper feeder 1's PF paper feed sensor when power is turned on. [32] (Cassette 2)            40: Paper does not arrive at the paper feeder 2's PF paper feed sensor. [33] (Cassette 3)            41: Paper does not pass the paper feeder 2's PF paper sensor. [33] (Cassette 3)            42: Paper remains at the paper feeder 2's PF paper feed sensor when power is turned on. [33] (Cassette 3)            A1: Paper does not arrive at the exit sensor. [47]            A3: Paper does not pass the exit sensor. [49]            E0: Paper misfeed occurs due to forced stop when an error occurs during printing. (such as opening of a cover) [00]            F0 to FE: Paper misfeed by another cause. [00]</p> <p>Note:            Within [ ] indicate paper misfeed locations. (Refer to figure 1-3-6 below.)</p>  <p style="text-align: center;"><b>Figure 1-3-6</b></p>

Service items		Description																																												
7 cont.		(b) Detail of paper source (Hexadecimal)																																												
		00: MP tray 01: Cassette 1 (Printer) 02: Cassette 2 (Paper feeder 1) 03: Cassette 3 (Paper feeder 2) 04 to 09: -																																												
		(c) Detail of paper size (Hexadecimal)																																												
		<table border="0"> <tr> <td>00: (indefinite)</td> <td>0B: B4</td> <td>23: Special 2</td> </tr> <tr> <td>01: Monarch</td> <td>0C: Ledger</td> <td>24: A3 wide</td> </tr> <tr> <td>02: Business</td> <td>0D: A5</td> <td>25: Ledger wide</td> </tr> <tr> <td>03: International DL</td> <td>0E: A6</td> <td>26: Full bleed paper (12 × 8)</td> </tr> <tr> <td>04: International C5</td> <td>0F: B6</td> <td>27: 8K</td> </tr> <tr> <td>05: Executive</td> <td>10: Commercial #9</td> <td>28: 16K-R</td> </tr> <tr> <td>06: Letter-R</td> <td>11: Commercial #6</td> <td>A8: 16K-E</td> </tr> <tr> <td>86: Letter-E</td> <td>12: ISO B5</td> <td>32: Statement-R</td> </tr> <tr> <td>07: Legal</td> <td>13: Custom size</td> <td>B2: Statement-E</td> </tr> <tr> <td>08: A4R</td> <td>1E: C4</td> <td>33: Folio</td> </tr> <tr> <td>88: A4E</td> <td>1F: Postcard</td> <td>34: Western type 2</td> </tr> <tr> <td>09: B5R</td> <td>20: Reply-paid postcard</td> <td>35: Western type 4</td> </tr> <tr> <td>89: B5E</td> <td>21: Oficio II</td> <td></td> </tr> <tr> <td>0A: A3</td> <td>22: Special 1</td> <td></td> </tr> </table>			00: (indefinite)	0B: B4	23: Special 2	01: Monarch	0C: Ledger	24: A3 wide	02: Business	0D: A5	25: Ledger wide	03: International DL	0E: A6	26: Full bleed paper (12 × 8)	04: International C5	0F: B6	27: 8K	05: Executive	10: Commercial #9	28: 16K-R	06: Letter-R	11: Commercial #6	A8: 16K-E	86: Letter-E	12: ISO B5	32: Statement-R	07: Legal	13: Custom size	B2: Statement-E	08: A4R	1E: C4	33: Folio	88: A4E	1F: Postcard	34: Western type 2	09: B5R	20: Reply-paid postcard	35: Western type 4	89: B5E	21: Oficio II		0A: A3	22: Special 1	
		00: (indefinite)	0B: B4	23: Special 2																																										
		01: Monarch	0C: Ledger	24: A3 wide																																										
		02: Business	0D: A5	25: Ledger wide																																										
		03: International DL	0E: A6	26: Full bleed paper (12 × 8)																																										
		04: International C5	0F: B6	27: 8K																																										
		05: Executive	10: Commercial #9	28: 16K-R																																										
06: Letter-R	11: Commercial #6	A8: 16K-E																																												
86: Letter-E	12: ISO B5	32: Statement-R																																												
07: Legal	13: Custom size	B2: Statement-E																																												
08: A4R	1E: C4	33: Folio																																												
88: A4E	1F: Postcard	34: Western type 2																																												
09: B5R	20: Reply-paid postcard	35: Western type 4																																												
89: B5E	21: Oficio II																																													
0A: A3	22: Special 1																																													
(d) Detail of paper type (Hexadecimal)																																														
<table border="0"> <tr> <td>01: Plain</td> <td>0A: Color</td> <td>15: Custom 1</td> </tr> <tr> <td>02: Transparency</td> <td>0B: Prepunched</td> <td>16: Custom 2</td> </tr> <tr> <td>03: Preprint</td> <td>0C: Envelope</td> <td>17: Custom 3</td> </tr> <tr> <td>04: Labels</td> <td>0D: Cardstock</td> <td>18: Custom 4</td> </tr> <tr> <td>05: Bond</td> <td>0E: Coated</td> <td>19: Custom 5</td> </tr> <tr> <td>06: Recycle</td> <td>0F: 2nd side</td> <td>1A: Custom 6</td> </tr> <tr> <td>07: Vellum</td> <td>10: Media 16</td> <td>1B: Custom 7</td> </tr> <tr> <td>08: Rough</td> <td>11: High quality</td> <td>1C: Custom 8</td> </tr> <tr> <td>09: Letter head</td> <td></td> <td></td> </tr> </table>			01: Plain	0A: Color	15: Custom 1	02: Transparency	0B: Prepunched	16: Custom 2	03: Preprint	0C: Envelope	17: Custom 3	04: Labels	0D: Cardstock	18: Custom 4	05: Bond	0E: Coated	19: Custom 5	06: Recycle	0F: 2nd side	1A: Custom 6	07: Vellum	10: Media 16	1B: Custom 7	08: Rough	11: High quality	1C: Custom 8	09: Letter head																			
01: Plain	0A: Color	15: Custom 1																																												
02: Transparency	0B: Prepunched	16: Custom 2																																												
03: Preprint	0C: Envelope	17: Custom 3																																												
04: Labels	0D: Cardstock	18: Custom 4																																												
05: Bond	0E: Coated	19: Custom 5																																												
06: Recycle	0F: 2nd side	1A: Custom 6																																												
07: Vellum	10: Media 16	1B: Custom 7																																												
08: Rough	11: High quality	1C: Custom 8																																												
09: Letter head																																														
(e) Detail of paper exit location (Hexadecimal)																																														
01: Face down tray (FU) 02 to 48: -																																														
8	Service Call (Self diagnostic error) Log	#	Count.	Service Code																																										
		Remembers 1 to 8 of occurrence of self diagnostics error. If the occurrence of the previous diagnostics error is less than 8, all of the diagnostics errors are logged.	The total page count at the time of the self diagnostics error.	Self diagnostic error code (See page 1-4-3)  Example 01.6000  01 means a self-diagnostic error; 6000 means a self diagnostic error code.																																										

Service items		Description		
<b>No.</b>	<b>Items</b>	<b>Description</b>		
9	Maintenance Log	<p><b>#</b></p> <p>Remembers 1 to 8 of occurrence of replacement. If the occurrence of the previous replacement of toner container is less than 8, all of the occurrences of replacement are logged.</p>	<p><b>Count.</b></p> <p>The total page count at the time of the replacement of the toner container.</p>	<p><b>Item</b></p> <p>Code of maintenance replacing item (1 byte, 2 categories)</p> <p>First byte (Replacing item) 01: Toner container</p> <p>Second byte (Type of replacing item) 00: Black (Fixed)</p> <p>First byte (Replacing item) 02: Maintenance kit</p> <p>Second byte (Type of replacing item) 01: (Fixed)</p>
10	Unknown Toner Log	<p><b>#</b></p> <p>Remembers 1 to 5 of occurrence of unknown toner detection.</p> <p>If the occurrence of the previous unknown toner detection is less than 5, all of the unknown toner detection are logged.</p>	<p><b>Count.</b></p> <p>The total page count at the time of the "Toner Empty" error with using an unknown toner container.</p>	<p><b>Item</b></p> <p>Unknown toner log code (1 byte, 2 categories)</p> <p>First byte 01: Fixed (Toner container)</p> <p>Second byte 00: Black (Fixed)</p>
11	Counter Log	<p><b>(f) Jam</b></p> <p>Indicates the log counter of paper jams depending on location.</p> <p>Refer to Paper Jam Log.</p> <p>All instances including those are not occurred are displayed.</p>	<p><b>(g) Self diagnostic error</b></p> <p>Indicates the log counter of self diagnostics errors depending on cause. (See page 1-4-3)</p> <p>Example C6000: 4</p> <p>Self diagnostics error 6000 has happened four times.</p>	<p><b>(h) Maintenance item replacing</b></p> <p>Indicates the log counter depending on the maintenance item for maintenance.</p> <p>T: Toner container 00: Black</p> <p>Example T00: 1</p> <p>The (black) toner container has been replaced once.</p>

This page is intentionally left blank.



### 1-4-1 Paper misfeed detection

#### (1) Paper misfeed indication

When a paper misfeed occurs, the printer immediately stops printing and displays the paper misfeed message on the operation panel. To remove paper misfed in the printer, pull out the paper cassette, open the front cover, rear cover or duplexer's cover, or remove the drum unit.

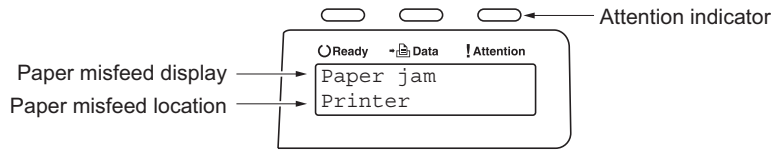

Figure 1-4-1

#### (2) Paper misfeed detection condition

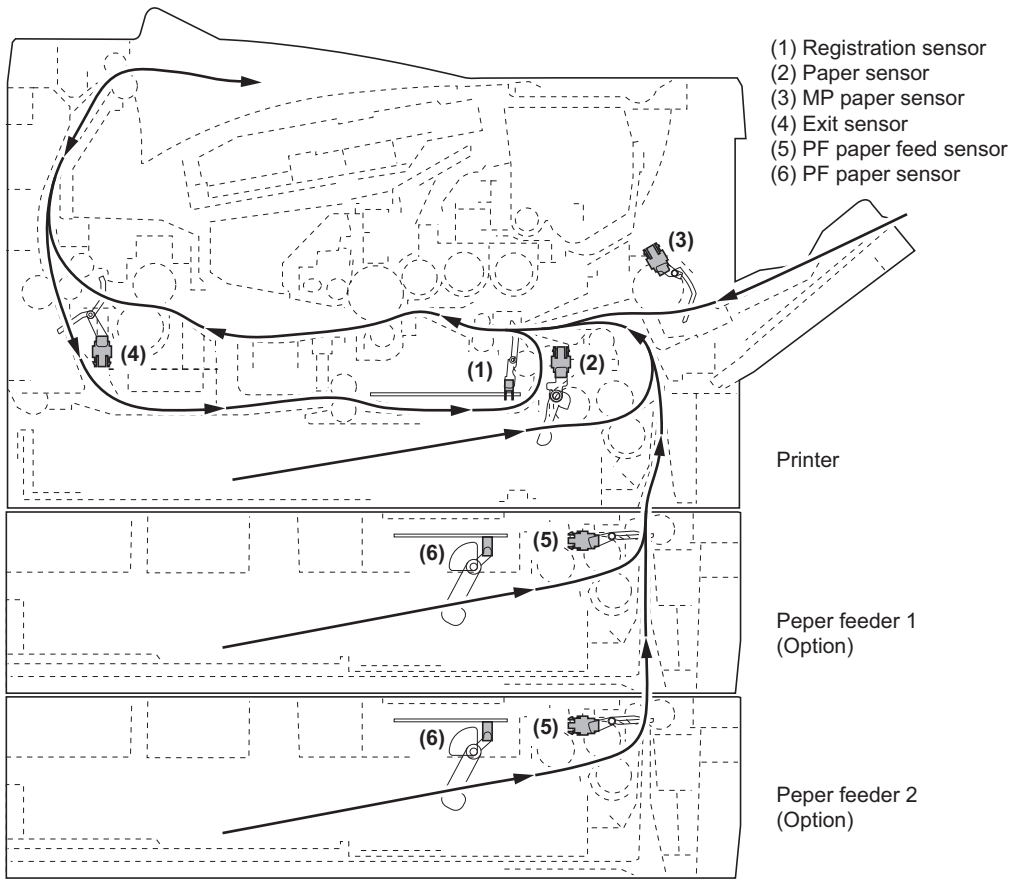

Figure 1-4-2

### 1-4-2 Self-diagnostic function

#### (1) Self-diagnostic function

This printer is equipped with self-diagnostic function. When a problem is detected, the printer stops printing and display an error message on the operation panel. An error message consists of a message prompting a contact to service personnel and a four-digit error code indicating the type of the error. (The display varies depending on the type of the error.)

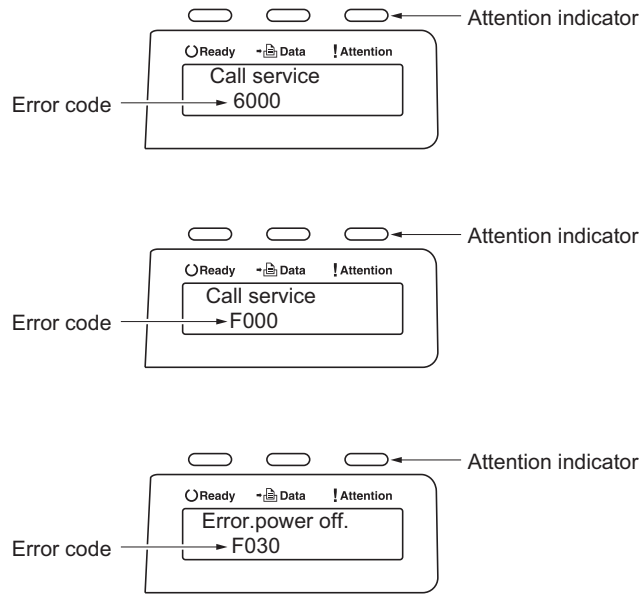

Figure 1-4-3

## (2) Self diagnostic codes

Code	Contents	Remarks	
		Causes	Check procedures/corrective measures
0100	Backup memory device error	Defective flash memory (U10).	Replace the control PWB (See page 1-5-19).
		Defective control PWB.	Replace the control PWB (See page 1-5-19).
0110	Backup memory data error	Defective flash memory (U10).	Replace the control PWB (See page 1-5-19).
		Defective control PWB.	Replace the control PWB (See page 1-5-19).
0120	MAC address data error	Defective control PWB.	Replace the control PWB (See page 1-5-19).
0150	Control PWB EEPROM error Detecting control PWB EEPROM (U300) communication error.	Improper installation control PWB EEPROM (U300).	Check the installation of the EEPROM (U300) and remedy if necessary (See page 1-5-19).
		Defective control PWB.	Replace the control PWB (See page 1-5-19).
0170	Billing counting error	Defective control PWB.	Replace the control PWB (See page 1-5-19).
0420	Paper feeder communication error Communication error between control PWB and optional paper feeder.	Improper installation paper feeder.	Follow installation instruction carefully again.
		Defective harness between control PWB (YC318) and paper feeder interface connector, or improper connector insertion.	Reinsert the connector. Also check for continuity within the connector harness. If none, remedy or replace the harness.
		Defective control PWB.	Replace the control PWB (See page 1-5-19).
		Defective harness between PF main PWB (YC5) and paper feeder interface connector, or improper connector insertion.	Reinsert the connector. Also check for continuity within the connector harness. If none, remedy or replace the harness (Refer to the service manual for the paper feeder).
		Defective PF main PWB.	Replace the PF main PWB (Refer to the service manual for the paper feeder).

Code	Contents	Remarks	
		Causes	Check procedures/corrective measures
2000	<b>Main motor error</b> The main motor ready input is not given for 2 s during the main motor is ON.	Defective harness between main motor (CN1) and control PWB (YC305), or improper connector insertion.	Reinsert the connector. Also check for continuity within the connector harness. If none, remedy or replace the harness.
		Defective drive transmission system of the main motor.	Check if the rollers and gears rotate smoothly. If not, grease the bushings and gears. Check for broken gears and replace if any.
		Defective main motor.	Replace the main motor (See page 1-5-28).
		Defective control PWB.	Replace the control PWB (See page 1-5-19).
4000	<b>Polygon motor (laser scanner unit) error</b> The polygon motor ready input is not given for 6 s during the polygon motor is ON.	Defective harness between polygon motor and control PWB (YC319), or improper connector insertion.	Reinsert the connector. Also check for continuity within the connector harness. If none, remedy or replace the harness.
		Defective laser scanner unit.	Replace the laser scanner unit (See page 1-5-29).
		Defective control PWB.	Replace the control PWB (See page 1-5-19).
4200	<b>BD error (laser scanner unit) error</b>	Defective laser scanner unit.	Replace the laser scanner unit (See page 1-5-29).
		Defective control PWB.	Replace the control PWB (See page 1-5-19).
6000	<b>Broken fuser heater lamp wire</b> The fuser temperature does not rise after the fuser heater lamp has been turned on.	Poor contact in the fuser thermistor connector terminals.	Reinsert the connector (See page 1-5-16).
		Poor contact in the fuser heater lamp connector terminals.	Reinsert the connector (See page 1-5-16).
		Fuser thermistor installed incorrectly.	Replace the fuser unit (See page 1-5-16).
		Fuser thermal cut-out triggered.	Replace the fuser unit (See page 1-5-16).
		Fuser heater lamp installed incorrectly.	Replace the fuser unit (See page 1-5-16).
		Broken fuser heater lamp wire.	Replace the fuser unit (See page 1-5-16).
6020	<b>Abnormally high fuser thermistor temperature</b> Fuser thermistor detects abnormally temperature.	Shorted fuser thermistor.	Replace the fuser unit (See page 1-5-16).
		Defective control PWB.	Replace the control PWB (See page 1-5-19).

Code	Contents	Remarks	
		Causes	Check procedures/corrective measures
6030	<b>Broken fuser thermistor wire</b> Input from fuser thermistor is 0 (A/D value).	Poor contact in the fuser thermistor connector terminals.	Reinsert the connector (See page 1-5-16).
		Broken fuser thermistor wire.	Replace the fuser unit (See page 1-5-16).
		Fuser thermistor installed incorrectly.	Replace the fuser unit (See page 1-5-16).
		Fuser thermal cut-out triggered.	Replace the fuser unit (See page 1-5-16).
		Fuser heater lamp installed incorrectly.	Replace the fuser unit (See page 1-5-16).
		Broken fuser heater lamp wire.	Replace the fuser unit (See page 1-5-16).
6400	<b>Zero cross signal error</b> The zero cross signal does not reach the control PWB for specified time.	Defective harness between high voltage PWB (YC202) and control PWB (YC311), or improper connector insertion.	Reinsert the connector. Also check for continuity within the connector harness. If none, remedy or replace the harness.
		Defective harness between power source PWB (YC103) and high voltage PWB (YC201), or improper connector insertion.	Reinsert the connector. Also check for continuity within the connector harness. If none, remedy or replace the harness.
		Defective power source PWB.	Replace the power source PWB (See page 1-5-22).
		Defective control PWB.	Replace the control PWB (See page 1-5-19).
F000	<b>Control PWB - Operation panel PWB communication error</b>	Defective harness between operation panel PWB (YC1) and control PWB (YC7), or improper connector insertion.	Reinsert the connector. Also check for continuity within the connector harness. If none, remedy or replace the harness.
		Defective operation panel PWB.	Replace the operation panel PWB.
		Defective control PWB.	Replace the control PWB (See page 1-5-19).
F010	<b>Control PWB checksum error</b>	Defective code ROM (flash memory).	Turn the power switch off/on to restart the printer. If the error is not resolved, replace the control PWB (See page 1-5-19).
		Defective control PWB.	Replace the control PWB (See page 1-5-19).

Code	Contents	Remarks	
		Causes	Check procedures/corrective measures
F020	Control PWB RAM checksum error	Defective main memory (RAM) on the control PWB.	Turn the power switch off/on to restart the printer. If the error is not resolved, replace control PWB (See page 1-5-19).
		Defective expanded memory (DIMM).	Replace the expanded memory (DIMM) (See page 1-2-4).
F030	Control PWB general failure	Defective control PWB.	Turn the power switch off/on to restart the printer. If the error is not resolved, replace control PWB (See page 1-5-19).
F040	Control PWB engine communication error	Defective control PWB.	Turn the power switch off/on to restart the printer. If the error is not resolved, replace control PWB (See page 1-5-19).
F050	Control PWB engine checksum error	Some error may have occurred when downloading the firmware of the control PWB.	Download the firmware of the control PWB again using the memory card (See page 1-6-4).
		Defective control PWB.	Turn the power switch off/on to restart the printer. If the error is not resolved, replace control PWB (See page 1-5-19).
F186	Control PWB video data control error	Defective control PWB.	Turn the power switch off/on to restart the printer. If the error is not resolved, replace control PWB (See page 1-5-19).

**1-4-3 Image formation problems**

(1) Completely blank printout.

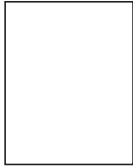

See page 1-4-8

(2) All-black printout.



See page 1-4-8

(3) Dropouts.

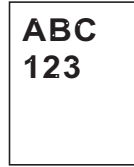

See page 1-4-9

(4) Black dots.

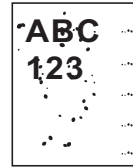

See page 1-4-9

(5) Black horizontal streaks.

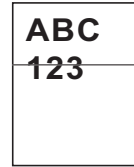

See page 1-4-9

(6) Black vertical streaks.

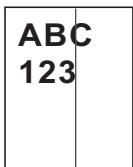

See page 1-4-10

(7) Unsharpness.

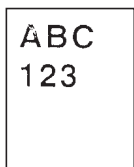

See page 1-4-10

(8) Gray background.

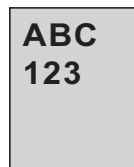

See page 1-4-10

(9) Dirt on the top edge or back of the paper.

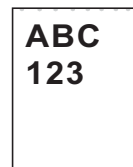

See page 1-4-11

(10) Undulated printing at the right edge (scanning start position).

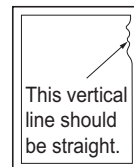

See page 1-4-11

**(1) Completely blank printout.**

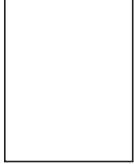
<b>Print example</b>	<b>Causes</b>	<b>Check procedures/corrective measures</b>
	Defective drum unit or developing unit.	Open the top cover and check that the drum unit and developing unit are correctly seated. Investigate that the terminals between the main charger unit and the drum unit are not in loose contact (See page 1-5-12 and 1-5-11).
	Defective transfer bias output or developing bias output.	Replace the high voltage PWB (See page 1-5-24).
	Poor contact of developing bias terminal (spring) and high voltage output terminal B (J401, J402, J403) on the high voltage PWB. Poor contact of transfer bias terminal (spring) and transfer bias terminal T (J201, J202, J203) on the high voltage PWB.	Check the high voltage PWB visually and correct or replace if necessary (See page 1-5-24).
	Defective laser scanner unit.	Replace the laser scanner unit (See page 1-5-29).
	Defective control PWB.	Replace the control PWB (See page 1-5-19).

**(2) All-black printout.**

<b>Print example</b>	<b>Causes</b>	<b>Check procedures/corrective measures</b>
	Defective main charger unit.	Open the top cover and check that the drum unit and developing unit are correctly seated (See page 1-5-12). Investigate that the terminals between the main charger unit and the drum unit are not in loose contact.
	Poor contact of main charger terminal (spring) and main charger output terminal M on the high voltage PWB.	Check the high voltage PWB visually and correct or replace if necessary (See page 1-5-24).
	Defective main charging output.	Replace the high voltage PWB (See page 1-5-24).
	Broken main charger wire.	Replace the main charger unit (See page 1-5-13).
	Defective control PWB.	Replace the control PWB (See page 1-5-19).

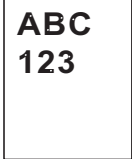

**(3) Dropouts.**

Print example	Causes	Check procedures/corrective measures
	Defective developing roller (developing unit).	If the defects occur at regular intervals of 62.8 mm/2 1/2" (See page 2-4-2), the problem may be the damaged developing roller (in the developing unit). Replace the developing unit (See page 1-5-11).
	Defective drum unit.	If the defects occur at regular intervals of 94 mm/3 11/16" (See page 2-4-2), the problem may be the damaged drum (in the drum unit). Replace the drum unit (See page 1-5-12).
	Defective fuser unit (heat roller or press roller).	If the defects occur at regular intervals of 73.162 mm/2 7/8", or 78.5 mm/3 1/16" (See page 2-4-2), the problem may be the damaged heat roller or press roller (in the fuser unit). Replace fuser unit (See page 1-5-16).
	Defective paper specifications.	Paper with rugged surface or dump tends to cause dropouts. Replace paper with the one that satisfies the paper specifications.
	Defective transfer roller installation.	The transfer roller must be supported by the bushes at the both ends. Clean the bush to remove oil and debris. Replace the transfer roller if necessary (See page 1-5-14).
	Defective transfer bias output.	Replace the high voltage PWB or control PWB (See page 1-5-24 or 1-5-19).

**(4) Black dots.**

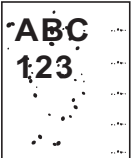
Print example	Causes	Check procedures/corrective measures
	Defective drum unit or developing unit.	If the defects occur at regular intervals of 94 mm/3 11/16" (See page 2-4-2), the problem may be the damaged drum (in the drum unit). Replace drum unit (See page 1-5-12). If the defects occur at random intervals, the toner may be leaking from the developing unit or drum unit. Replace the developing unit or drum unit (See page 1-5-11 or 1-5-12).

**(5) Black horizontal streaks.**

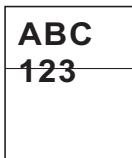
Print example	Causes	Check procedures/corrective measures
	Defective drum unit's ground.	Check that the drum shaft and the grounding tab (printer) are in good contact. Apply the grounding tab a small amount of electroconductive grease as required.
	Defective drum unit.	Replace the drum unit (See page 1-5-12).

**(6) Black vertical streaks.**

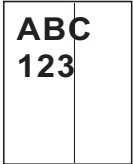
Print example	Causes	Check procedures/corrective measures
	Adhesion of oxide to main charger wire.	Remove the drum unit (See page 1-5-12). Slide the charger cleaner (green) left and right 2 or 3 times to clean the charger wire, then return it to its original position (CLEANER HOME POSITION). Refer to the operation guide.
	Defective drum unit.	A streak of toner remaining on drum after printing means that the cleaning blade (in the drum unit) is not working properly. Replace the drum unit (See page 1-5-12).
	Defective developing roller (developing unit).	Replace the developing unit (See page 1-5-11).

**(7) Unsharpness.**

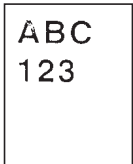
Print example	Causes	Check procedures/corrective measures
	Defective paper specifications.	Replace paper with the one that satisfies the paper specification.
	Defective transfer roller installation.	The transfer roller must be supported by the bushes at the both ends. Clean the bush to remove oil and debris. Replace the transfer roller if necessary (See page 1-5-14).
	Defective transfer bias output.	Replace the high voltage PWB or control PWB (See page 1-5-24 or 1-5-19).
	EcoPrint mode setting.	The EcoPrint mode can provides faint, unsharp printing because it acts to conserve toner for draft printing purpose. For normal printing, turn the EcoPrint mode off by using the operator panel. For details, refer to the operation guide.

**(8) Gray background.**

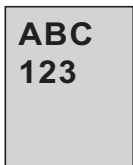
Print example	Causes	Check procedures/corrective measures
	Print density setting.	The print density may be set too high. Try adjusting the print density. For details, refer to the operation guide.
	Defective potential on the drum surface.	Replace the drum unit (See page 1-5-12).
	Defective main charger grid.	Clean the main charger grid (See page 1-5-13).
	Defective developing roller (developing unit).	If a developing unit which is known to work normally is available for check, replace the current developing unit in the printer with the normal one. If the symptom disappears, replace the developing unit with a new one (See page 1-5-11).

**(9) Dirt on the top edge or back of the paper.**

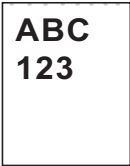
Print example	Causes	Check procedures/corrective measures
	Toner contamination in various parts.	Dirty edges and back of the paper can be caused by toner accumulated on such parts as the paper chute guide, paper conveying paths, the bottom of the drum and developing unit, and the fuser unit inlet. Clean these areas and parts to remove toner.
	Defective transfer roller.	If the transfer roller is contaminated with toner, clean the transfer roller using a vacuum cleaner or by continuously printing a low density page until the symptom has faded away.

**(10) Undulated printing at the right edge (scanning start position).**

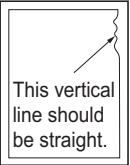
Print example	Causes	Check procedures/corrective measures
	Defective polygon motor (laser scanner unit).	Replace the laser scanner unit (See page 1-5-29).
	Defective control PWB.	Replace the control PWB (See page 1-5-19).

### 1-4-4 Electric problems

Problem	Causes	Check procedures/corrective measures
(1) The machine does not operate when the power switch is turned on.	No electricity at the power outlet.	Measure the input voltage.
	The power cord is not plugged in properly.	Check the contact between the power plug and the outlet.
	The top cover is not closed completely.	Check the top cover.
	Broken power cord.	Check for continuity. If none, replace the cord.
	Defective power switch.	Check for continuity across the contacts. If none, replace the power source PWB (See page 1-5-22).
	Blown fuse in the power source PWB.	Check for continuity. If none, remove the cause of blowing and replace the power source PWB (See page 1-5-22).
	Defective interlock switch.	Check for continuity across the contacts of interlock switch. If none, replace the power source PWB (See page 1-5-22).
	Defective power source PWB.	Replace the power source PWB (See page 1-5-22).
	Defective control PWB.	Replace the control PWB (See page 1-5-19).
(2) Right cooling fan motor does not operate.	Broken right cooling fan motor coil.	Check for continuity across the coil. If none, replace the right cooling fan motor.
	Defective harness between right cooling fan motor and control PWB (YC315), or improper connector insertion.	Reinsert the connector. Also check for continuity within the connector harness. If none, remedy or replace the harness.
	Defective control PWB.	Replace the control PWB (See page 1-5-19).
(3) Left cooling fan motor does not operate.	Broken left cooling fan motor coil.	Check for continuity across the coil. If none, replace the left cooling fan motor.
	Defective harness between left cooling fan motor and control PWB (YC104), or improper connector insertion.	Reinsert the connector. Also check for continuity within the connector harness. If none, remedy or replace the harness.
	Defective control PWB.	Replace the control PWB (See page 1-5-19).
(4) Registration clutch does not operate.	Broken registration clutch coil.	Check for continuity across the coil. If none, replace the registration clutch.
	Defective harness between registration clutch and control PWB (YC308), or improper connector insertion.	Reinsert the connector. Also check for continuity within the connector harness. If none, remedy or replace the harness.
	Defective control PWB.	Replace the control PWB (See page 1-5-19).
(5) Paper feed clutch does not operate.	Broken paper feed clutch coil.	Check for continuity across the coil. If none, replace the paper feed clutch.
	Defective harness between paper feed clutch and control PWB (YC308), or improper connector insertion.	Reinsert the connector. Also check for continuity within the connector harness. If none, remedy or replace the harness.
	Defective control PWB.	Replace the control PWB (See page 1-5-19).

<b>Problem</b>	<b>Causes</b>	<b>Check procedures/corrective measures</b>
(6) Developing clutch does not operate.	Broken developing clutch coil.	Check for continuity across the coil. If none, replace the developing clutch.
	Defective harness between developing clutch and control PWB (YC308), or improper connector insertion.	Reinsert the connector. Also check for continuity within the connector harness. If none, remedy or replace the harness.
	Defective control PWB.	Replace the control PWB (See page 1-5-19).
(7) MP paper feed solenoid does not operate.	Broken MP paper feed solenoid coil.	Check for continuity across the coil. If none, replace the MP paper feed solenoid.
	Defective harness between MP paper feed solenoid and control PWB (YC309), or improper connector insertion.	Reinsert the connector. Also check for continuity within the connector harness. If none, remedy or replace the harness.
	Defective control PWB.	Replace the control PWB (See page 1-5-19).
(8) Duplex solenoid does not operate.	Broken duplex solenoid coil.	Check for continuity across the coil. If none, replace the duplex solenoid.
	Defective harness between duplex solenoid and control PWB (YC317), or improper connector insertion.	Reinsert the connector. Also check for continuity within the connector harness. If none, remedy or replace the harness.
	Defective control PWB.	Replace the control PWB (See page 1-5-19).
(9) Eraser lamp does not turn on.	Defective harness between eraser lamp (YC701) and control PWB (YC316), or improper connector insertion.	Reinsert the connector. Also check for continuity within the connector harness. If none, remedy or replace the harness.
	Defective eraser lamp (PWB).	Replace the eraser lamp (PWB) (See page 1-5-31).
	Defective control PWB.	Replace the control PWB (See page 1-5-19).
(10) Paper indicator is flashing when paper is present in the cassette.	Defective paper sensor.	Replace the paper sensor.
	Defective harness between paper sensor and control PWB (YC306), or improper connector insertion.	Reinsert the connector. Also check for continuity within the connector harness. If none, remedy or replace the harness.
(11) A paper jam in the paper feed/conveying section or fuser section is indicated when the power switch is turned on.	A piece of paper torn from paper is caught around registration sensor or exit sensor.	Check and remove if any.
	Defective registration sensor on the high voltage PWB.	Replace the high voltage PWB (See page 1-5-24).
	Defective exit sensor.	Replace the exit sensor.
(12) Attention indicator is lit when the top cover is closed.	Defective interlock switch on the power source PWB.	Check for continuity across the interlock switch. If there is no continuity when the interlock switch is on, replace the power source PWB (See page 1-5-22).

**1-4-5 Mechanical problems**

<b>Problem</b>	<b>Causes/check procedures</b>	<b>Corrective measures</b>
(1) No primary paper feed.	Check if the surfaces of the paper feed roller is dirty with paper powder.	Clean with isopropyl alcohol.
	Check if the paper feed roller is deformed.	Check visually and replace any deformed paper feed roller (assembly) (See page 1-5-6).
	Defective paper feed clutch installation.	Check visually and remedy if necessary.
(2) No secondary paper feed.	Check if the surfaces of the upper and lower registration rollers are dirty with paper powder.	Clean with isopropyl alcohol.
	Defective registration clutch installation.	Check visually and remedy if necessary.
(3) Skewed paper feed.	Paper width guide in a cassette installed incorrectly.	Check the paper width guide visually and correct or replace if necessary.
(4) Multiple sheets of paper are fed at one time.	Check if the separator pad or MPF separation pad is worn.	Replace the separator pad if it is worn.
	Check if the paper is curled.	Replace the paper.
(5) Paper jams.	Check if the paper is excessively curled.	Replace the paper.
	Check if the contact between the upper and lower registration rollers is correct.	Check visually and remedy if necessary.
	Check if the heat roller or press roller is extremely dirty or deformed.	Replace the fuser unit (See page 1-5-16).
	Check if the contact between the ejection roller and fuser ejection pulley is correct.	Check visually and remedy if necessary.
(6) Toner drops on the paper conveying path.	Check if the drum unit or developing unit is extremely dirty.	Clean the drum unit or developing unit (See page 1-5-11 or 1-5-12).
(7) Abnormal noise is heard.	Check if the pulleys, rollers and gears operate smoothly.	Grease the bearings and gears.
	Check if the following electromagnetic clutches are installed correctly: Paper feed clutch, registration clutch and developing clutch.	Check visually and remedy if necessary.

## **1-5-1 Precautions for assembly and disassembly**

### **(1) Precautions**

Be sure to turn the power switch off and disconnect the power plug before starting disassembly.

When handling PWBs, do not touch connectors with bare hands or damage the PWB.

Do not touch any PWB containing ICs with bare hands or any object prone to static charge.

When removing the hook of the connector, be sure to release the hook.

Take care not to get the wire caught.

To reassemble the parts, use the original screws. If the types and the sizes of screws are not known, refer to the PARTS LIST.

### **(2) Drum**

Note the following when handling or storing the drum.

When removing the drum unit, never expose the drum surface to strong direct light.

Keep the drum at an ambient temperature between 0 °C/32 °F and 40 °C/104 °F and at a relative humidity not higher than 90% RH. Avoid abrupt changes in temperature and humidity.

Avoid exposure to any substance which is harmful to or may affect the quality of the drum.

Do not touch the drum surface with any object. Should it be touched by hands or stained with oil, clean it.

### **(3) Toner container**

Store the toner container in a cool, dark place.

Avoid direct light and high humidity.

**(4) How to tell a genuine Kyocera Mita toner container**

As a means of brand protection, the Kyocera Mita toner container utilizes an optical security technology to enable visual validation. A validation viewer is required to accomplish this.

Hold the validation viewer over the left side part of the brand protection seal on the toner container. Through each window of the validation viewer, the left side part of the seal should be seen as follows:

A black-colored band when seen through the left side window

A shiny or gold-colored band when seen through the right side window

The above will reveal that the toner container is a genuine Kyocera Mita branded toner container, otherwise, it is a counterfeit.

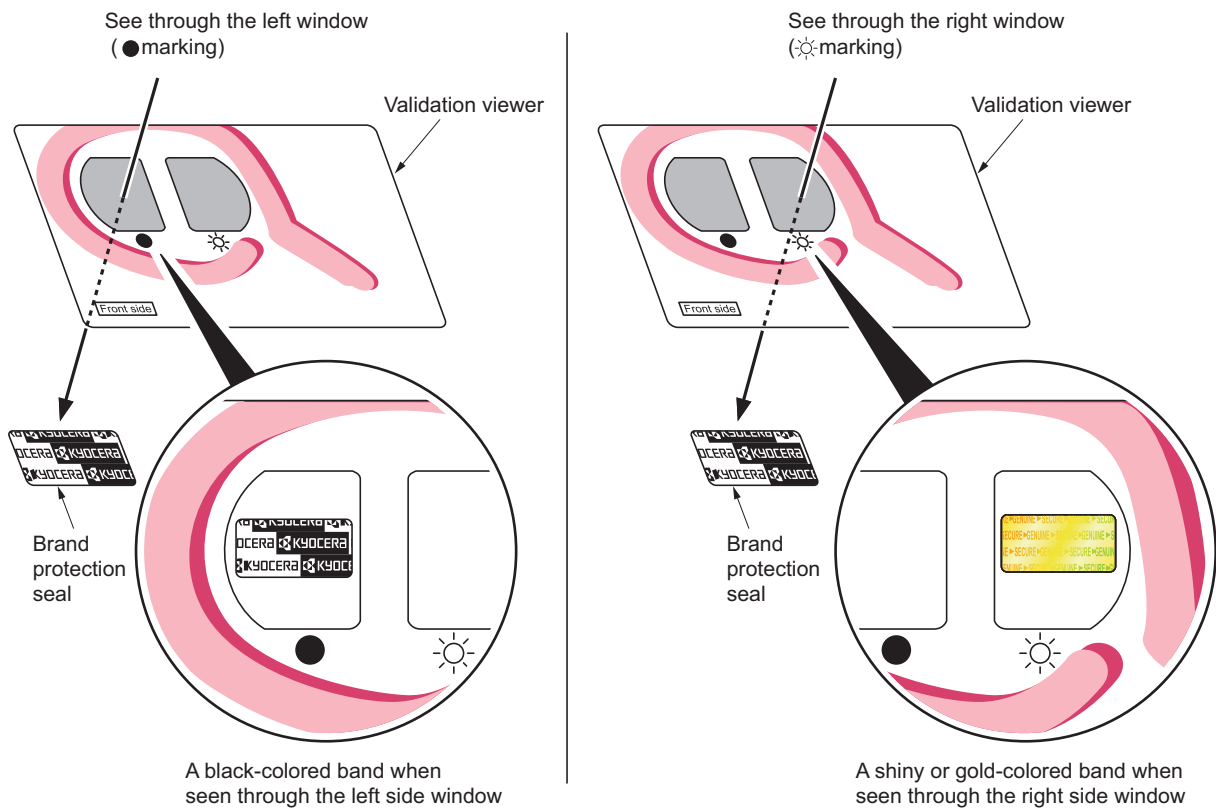

**Figure 1-5-1**

The brand protection seal has an incision as shown below to prohibit reuse.

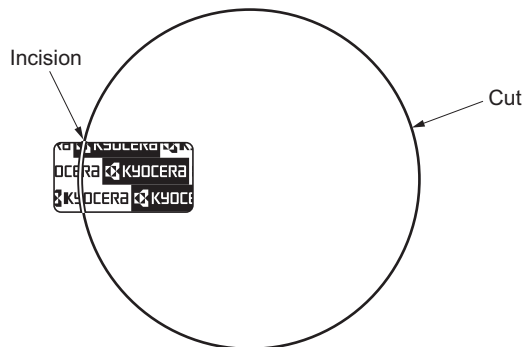

**Figure 1-5-2**



## 1-5-2 Outer covers

### (1) Detaching and refitting the top cover

#### Procedure

1. Open the top cover.
2. Remove two screws.

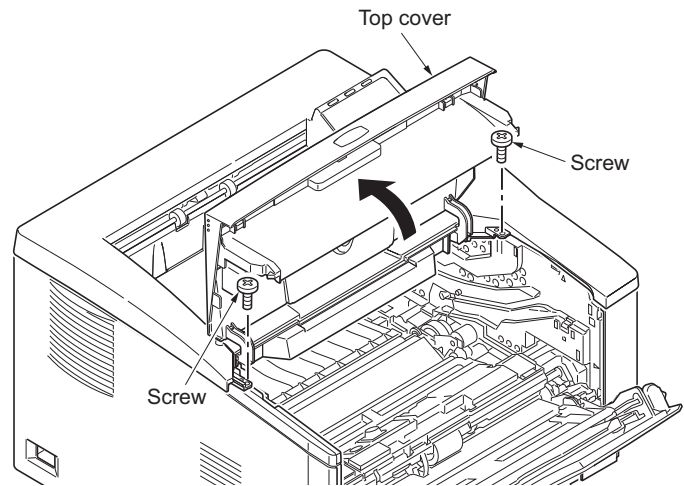

Figure 1-5-3

3. Extract the boss from the hole.
4. Unhook the A hook.
5. Unhook two B hooks.
6. Remove the connector.
7. Remove the top cover.

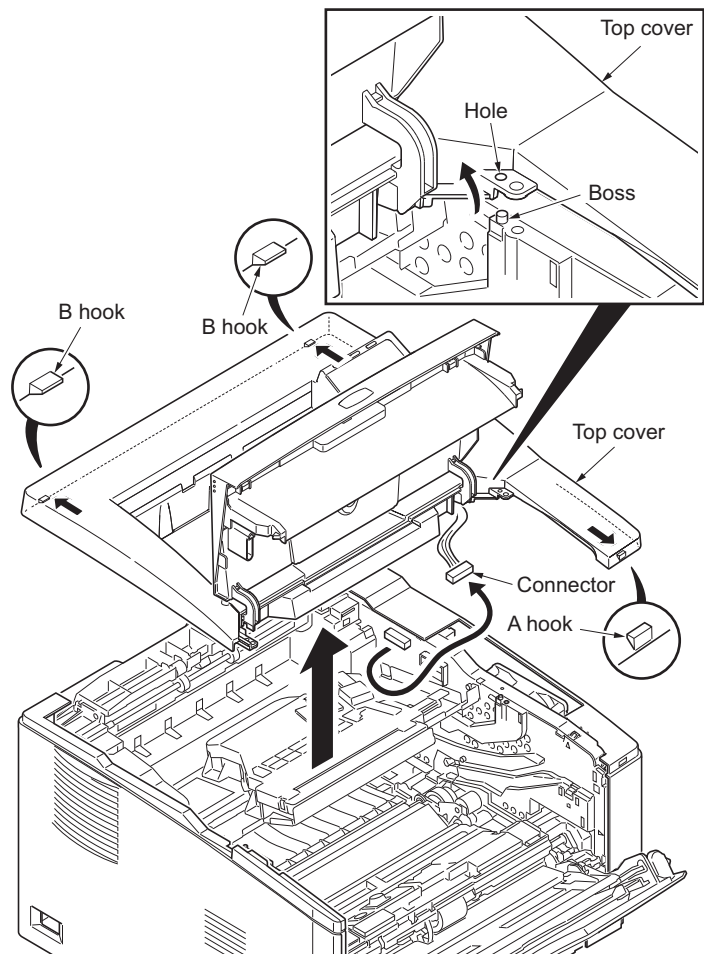
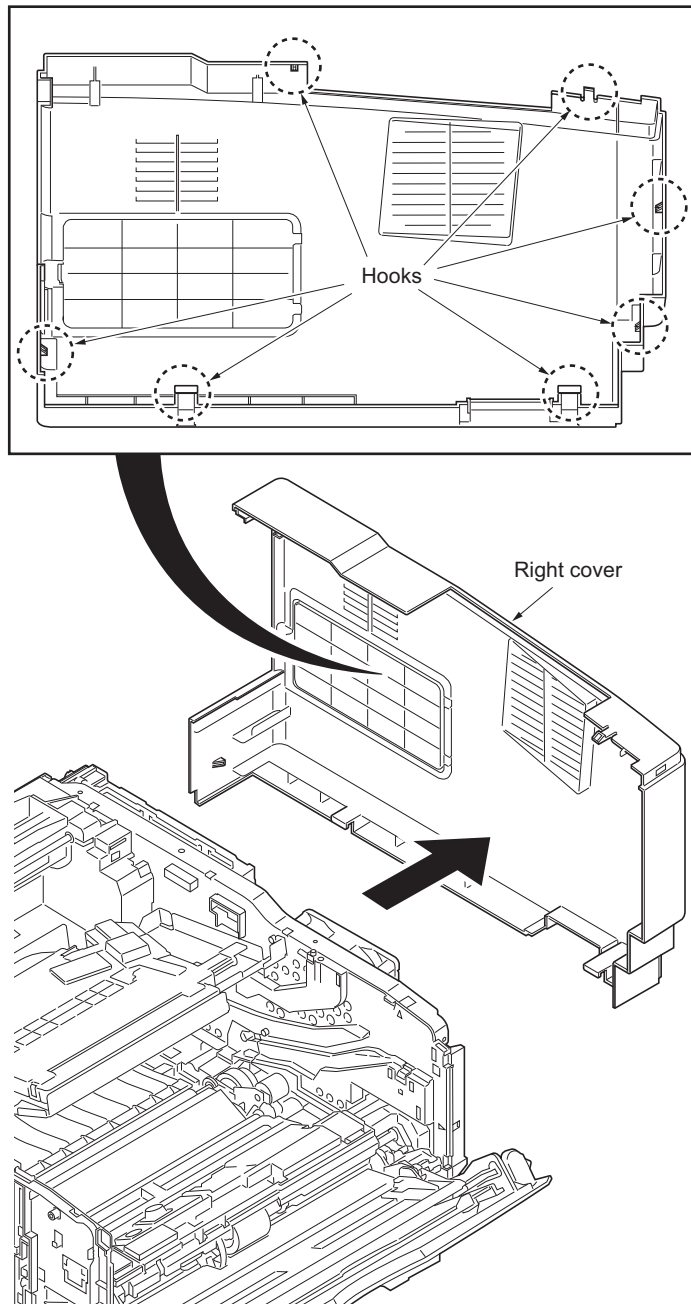

Figure 1-5-4

**(2) Detaching and refitting the right and left covers**

**Procedure**

1. Remove the top cover (See page 1-5-3).
2. Remove the cassette (See page 1-5-6).
3. Open the front cover.
4. Unhook seven hooks and then remove the right cover.



**Figure 1-5-5**

5. Unhook seven hooks and then remove the left cover.

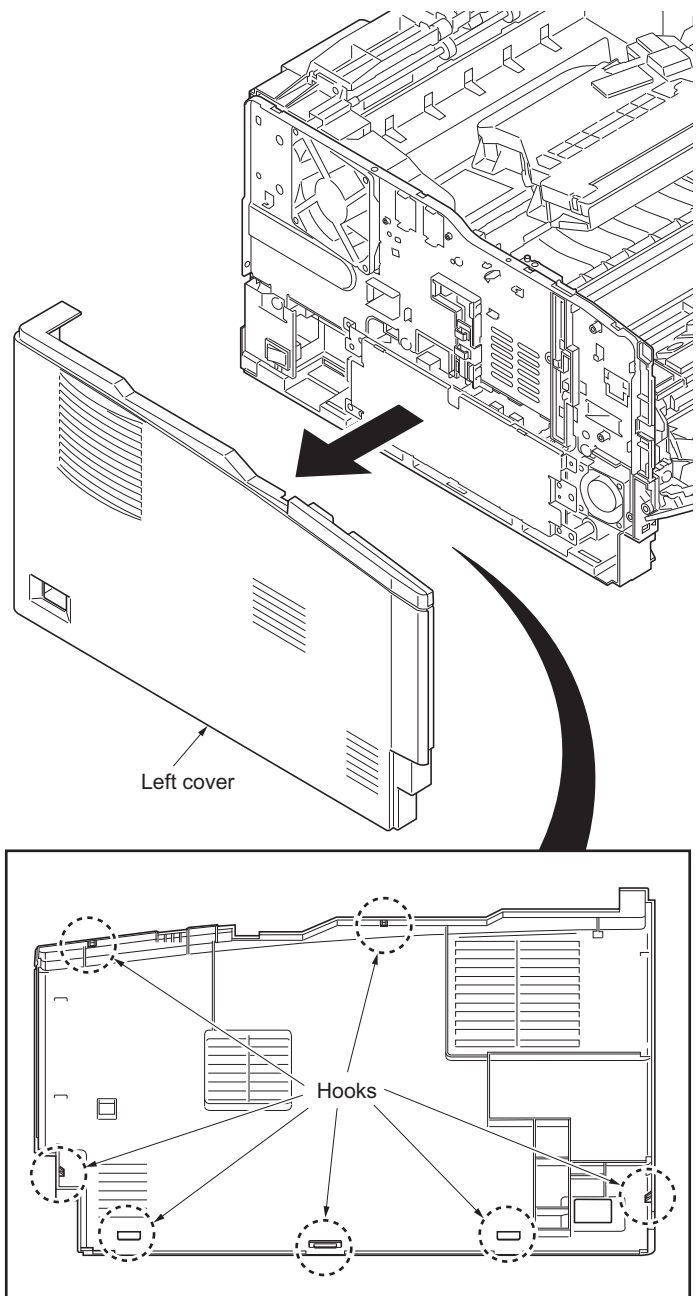

Figure 1-5-6

### 1-5-3 Paper feed section

#### (1) Detaching and refitting the paper feed roller assembly (paper feed roller and pickup roller)

##### Procedure

1. Remove the cassette.

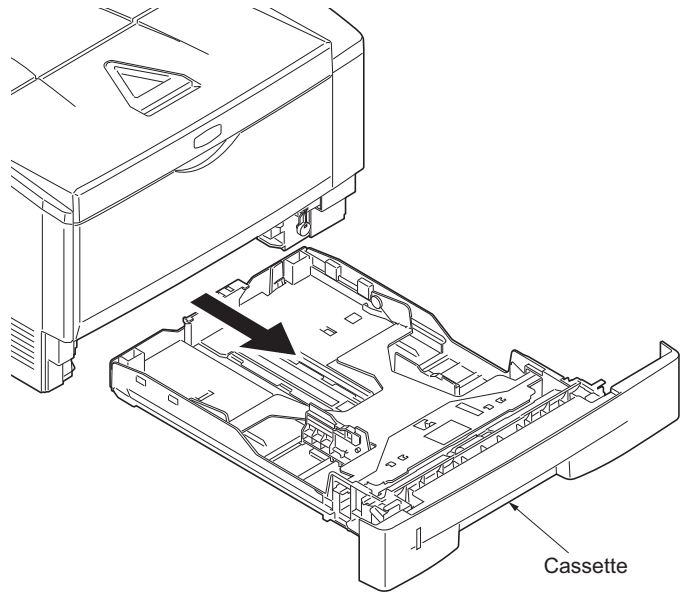

Figure 1-5-7

2. Slide the feed shaft.
3. While pressing the lever and then remove the paper feed roller assembly.

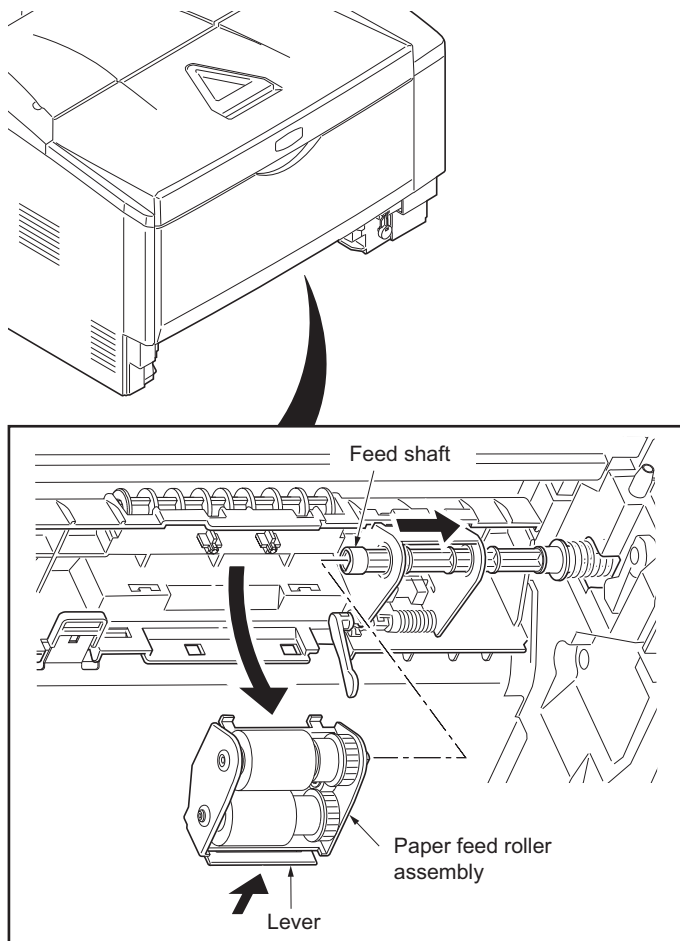
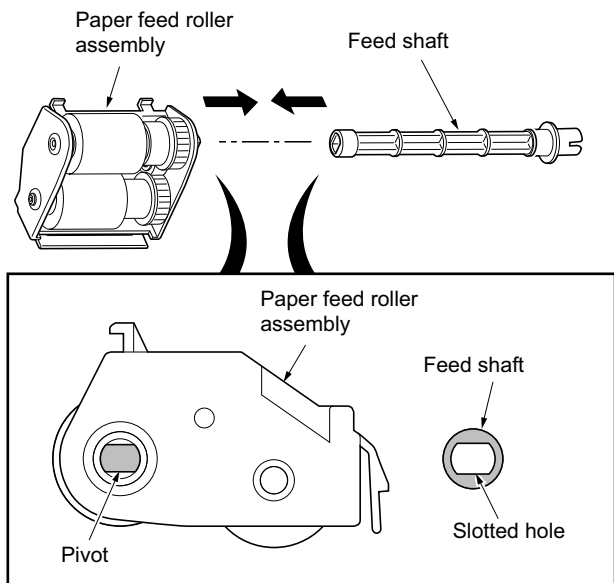

Figure 1-5-8

4. Check or replace the paper feed roller assembly and refit all the removed parts. When refitting the paper feed roller assembly, be sure to align the paper feed roller pivot with the slotted hole on the feed shaft.

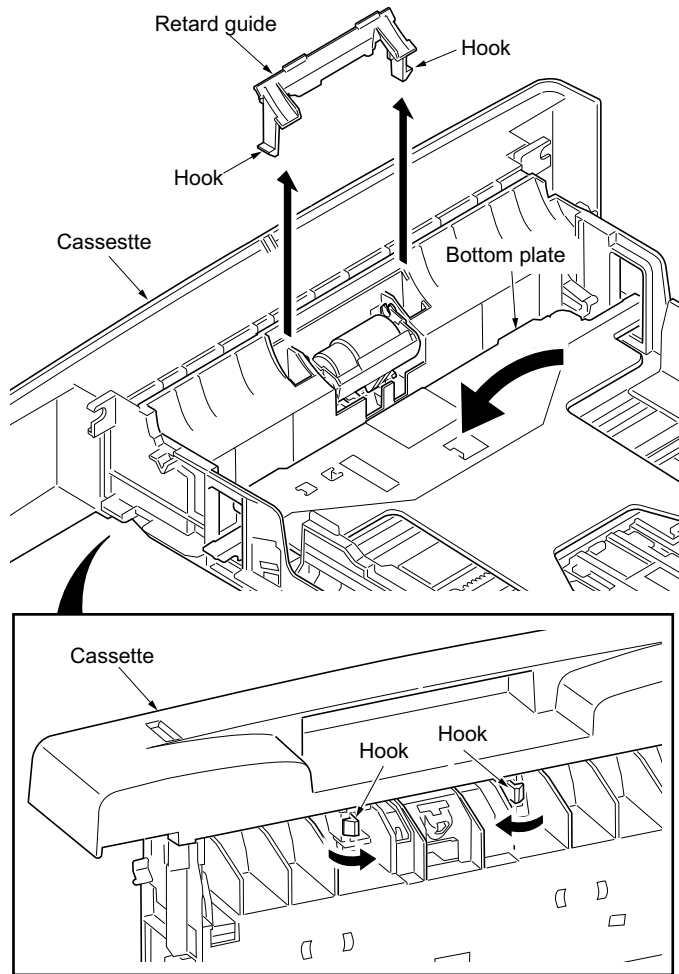

**Figure 1-5-9**

**(2) Detaching and refitting the retard roller assembly**

**Procedure**

1. Remove the cassette (See page 1-5-6).
2. Push the bottom plate down until it locks.
3. Unhook two hooks and then remove the retard guide.



**Figure 1-5-10**

4. Remove the retard roller assembly.

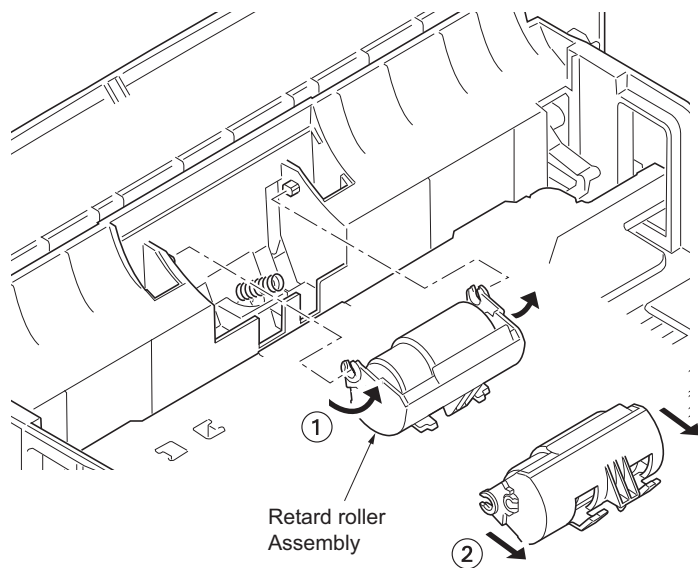

**Figure 1-5-11**

5. Check or replace the retard roller assembly and refit all the removed parts.  
Caution: Before refitting the retard roller assembly, firmly install the spring onto the projection of the retard roller assembly.

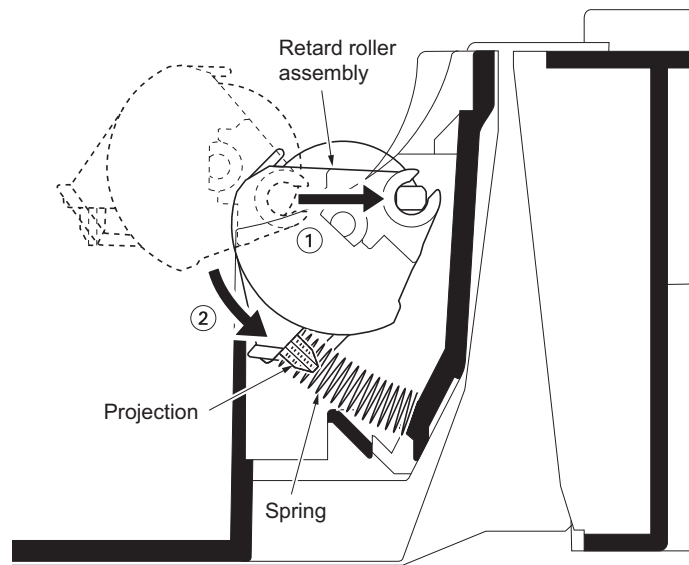
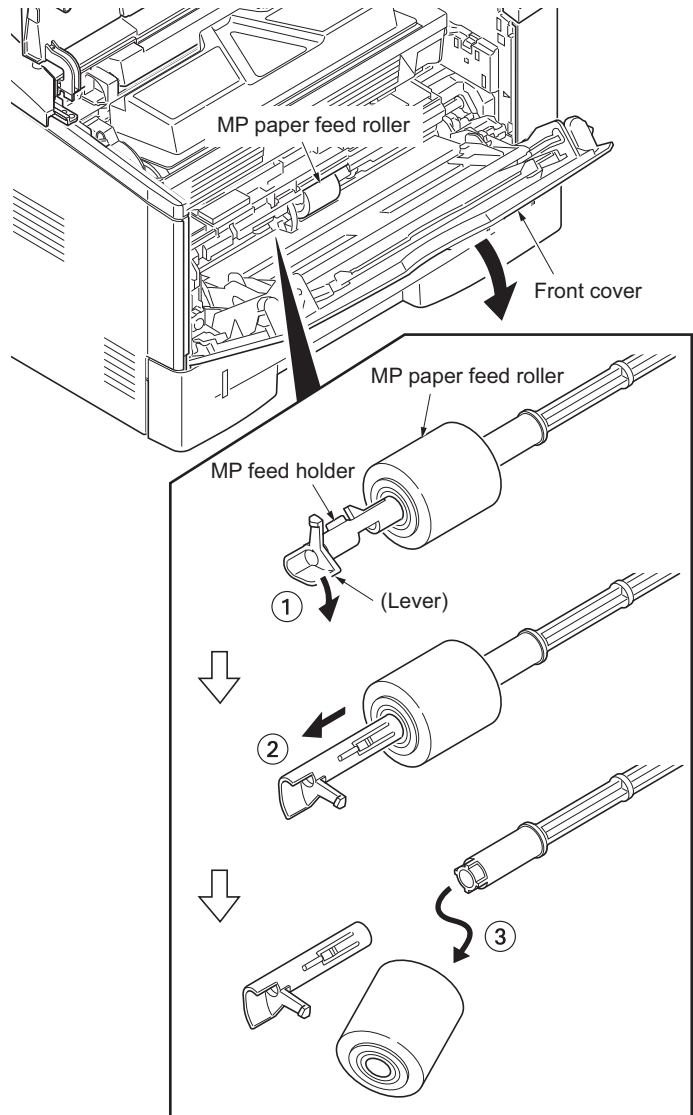

Figure 1-5-12

**(3) Detaching and refitting the MP paper feed roller**

**Procedure**

1. Open the front cover.
2. Pull the MP feed holder (lever) down (1).
3. Slide the MP feed holder (2).
4. Remove the MP paper feed roller (3).



**Figure 1-5-13**

5. Check or replace the MP paper feed roller and refit all the removed parts. When refitting the MP paper feed roller, be sure to align the MPF feed shaft pivot with the slotted hole on the MP paper feed roller.

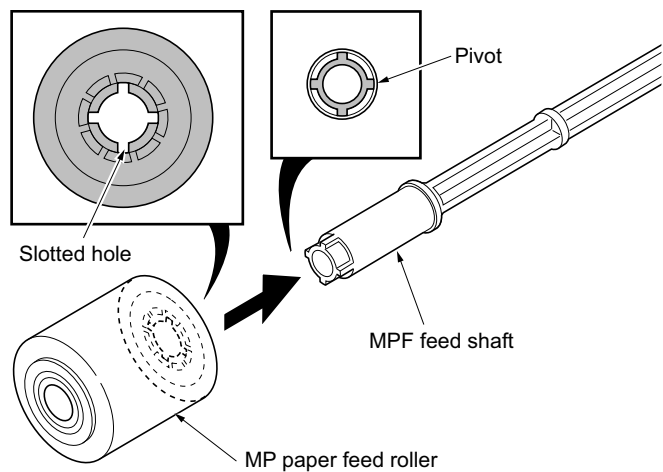

**Figure 1-5-14**



## 1-5-4 Developing section

### (1) Detaching and refitting the developing unit

#### Procedure

1. Open the top cover.
2. Open the front cover.
3. Remove the developing unit (with toner container).
4. Check or replace the developing unit and refit all the removed parts.
5. When the developing unit is replaced with a new one, carry out the following procedure.
6. Perform toner install mode in the service mode (see page 1-3-9).

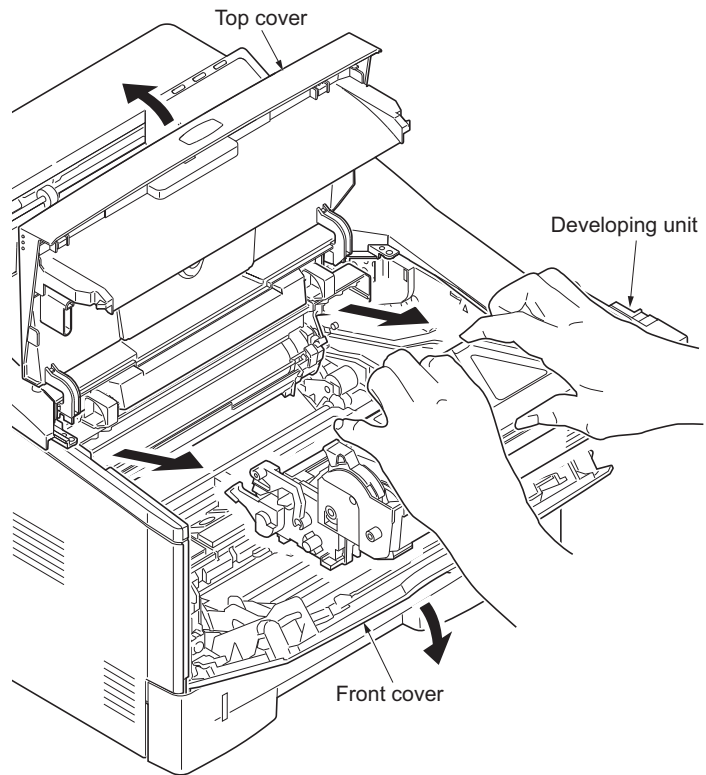

Figure 1-5-15

## 1-5-5 Drum section

### (1) Detaching and refitting the drum unit

#### Procedure

1. Remove the developing unit (See page 1-5-11).
2. Remove the drum unit.
3. Check or replace the drum unit and refit all the removed parts.

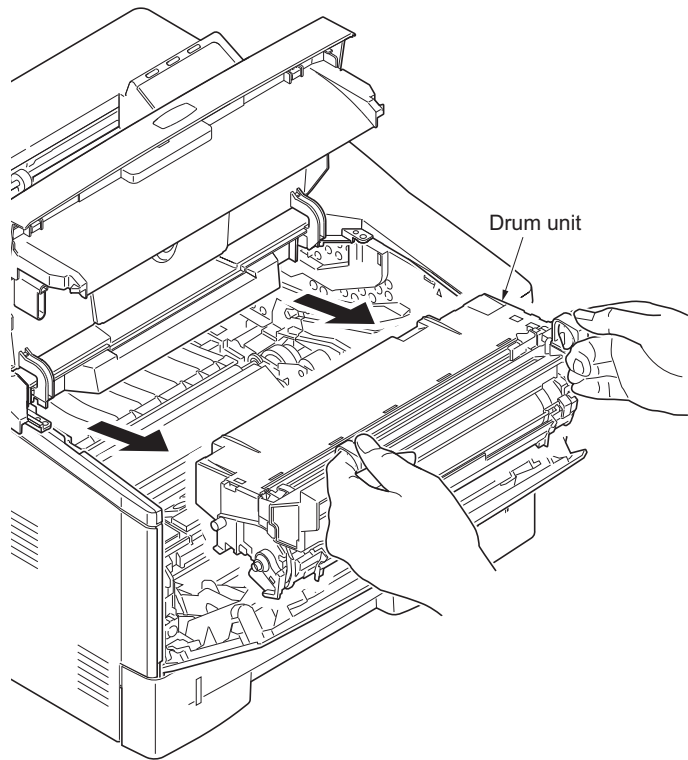
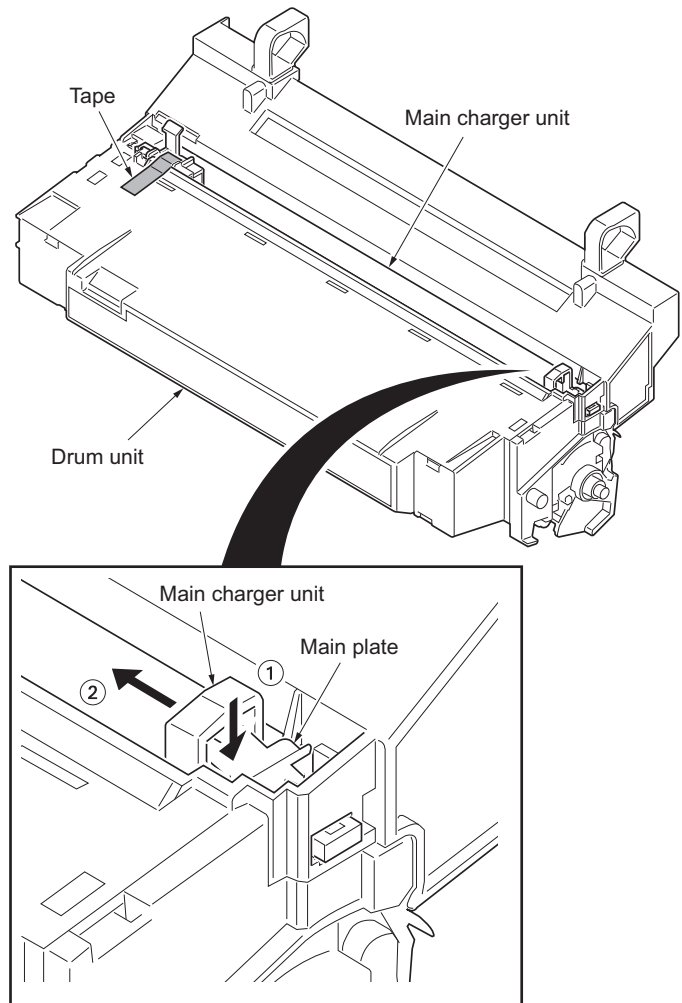

Figure 1-5-16

**(2) Detaching and refitting the main charger unit****Procedure**

1. Remove the drum unit (See page 1-5-12).
2. Remove the tape.
3. While pushing on the main plate (1), slide the main charger unit (2).

**Figure 1-5-17**

4. Remove the main charger unit by lifting it.
5. Check or replace the main charger unit and refit all the removed parts.

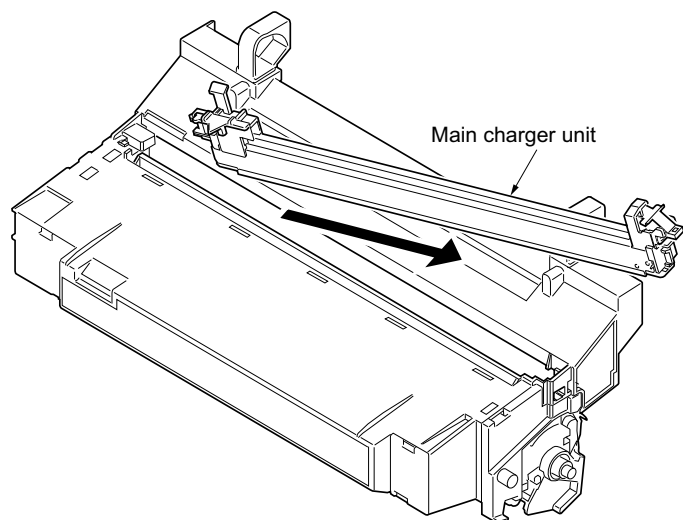
**Figure 1-5-18**

### 1-5-6 Transfer/separation section

#### (1) Detaching and refitting the transfer roller

##### Procedure

1. Remove the developing unit (See page 1-5-11).
2. Remove the drum unit (See page 1-5-12).
3. Slide the paper chute guide and unhook the hooks.
4. Remove the paper chute guide.

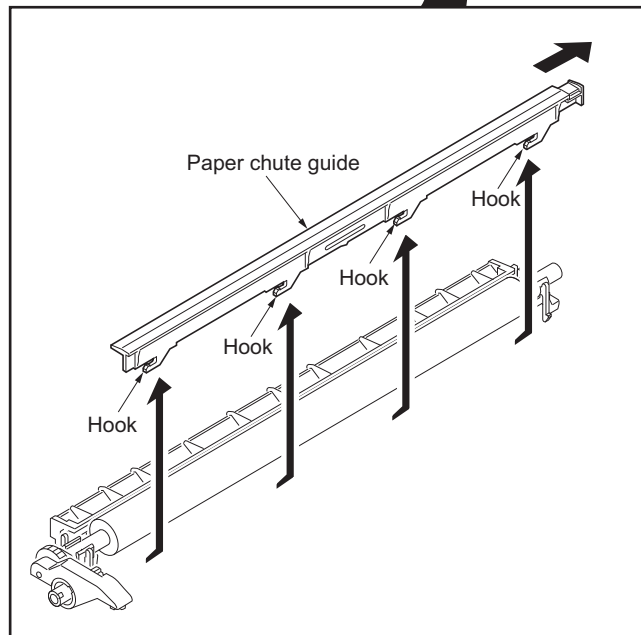
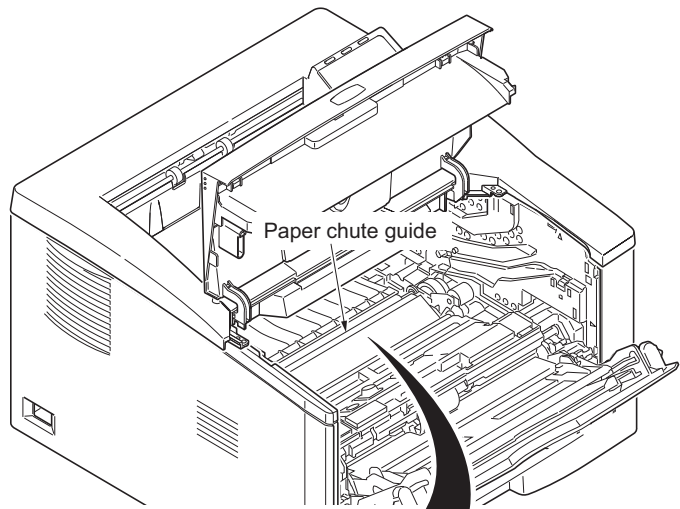

Figure 1-5-19

5. Remove the transfer roller's shaft from the both transfer bushes.
6. Remove the gear Z16 from the transfer roller.

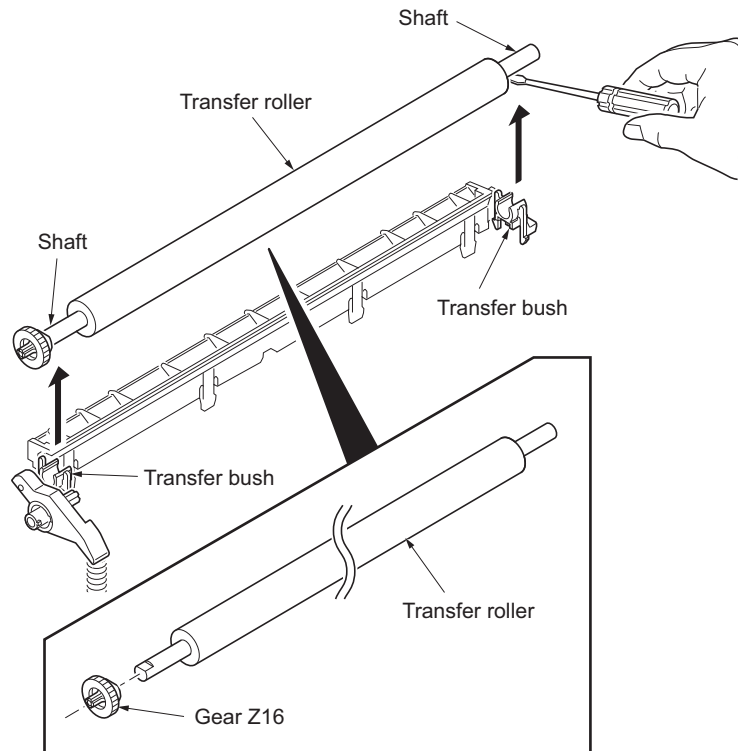

Figure 1-5-20

7. Check or replace the transfer roller and refit all the removed parts.  
**Caution:** When refitting the transfer roller, be careful about following point.  
 Push the release lever to raise the lever end, then insert the front of gear Z16 under the release lever end.

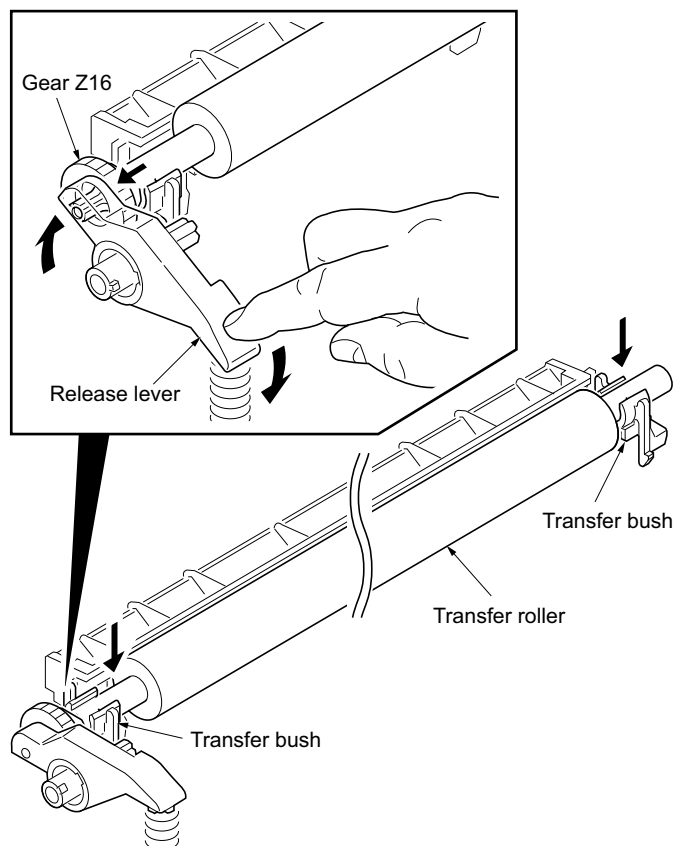

Figure 1-5-21

### 1-5-7 Fuser section

#### (1) Detaching and refitting the fuser unit

##### Procedure

1. Remove the outer covers (See page 1-5-3).
2. Remove two connectors.
3. Release the wires from wire clamps.

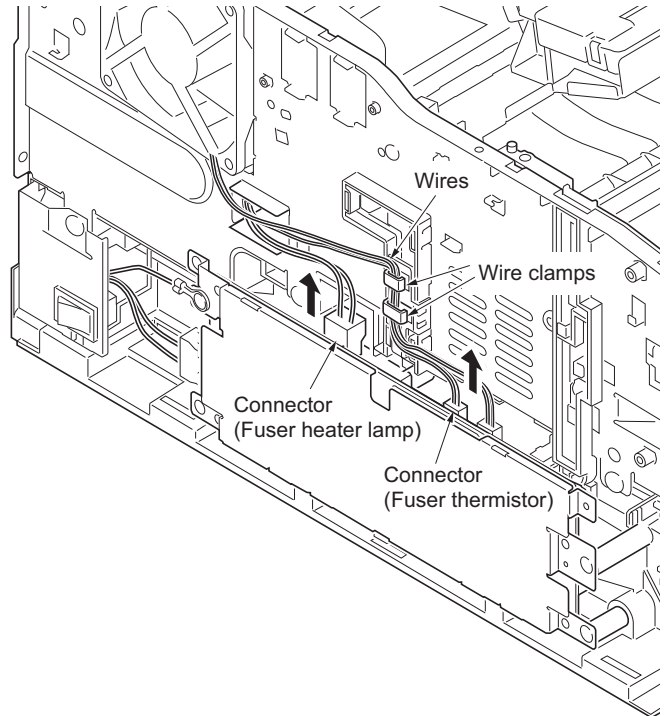

Figure 1-5-22

4. Remove the connector.

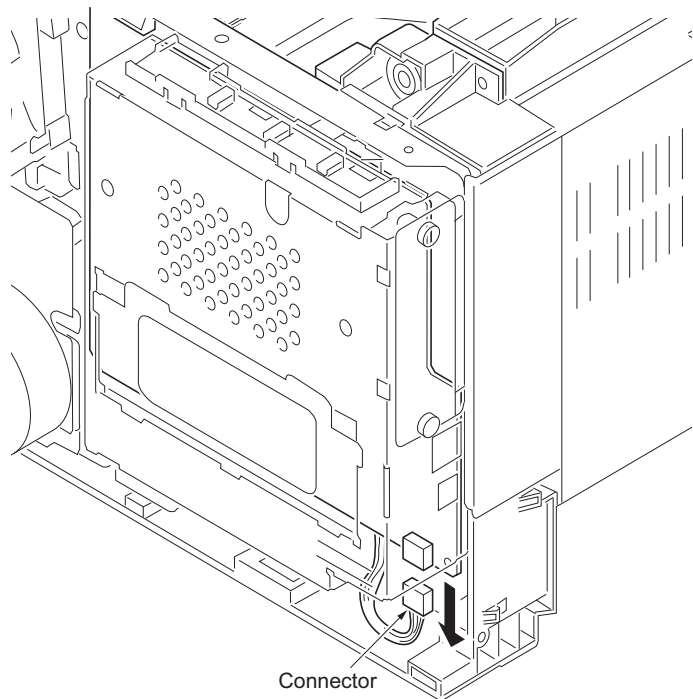
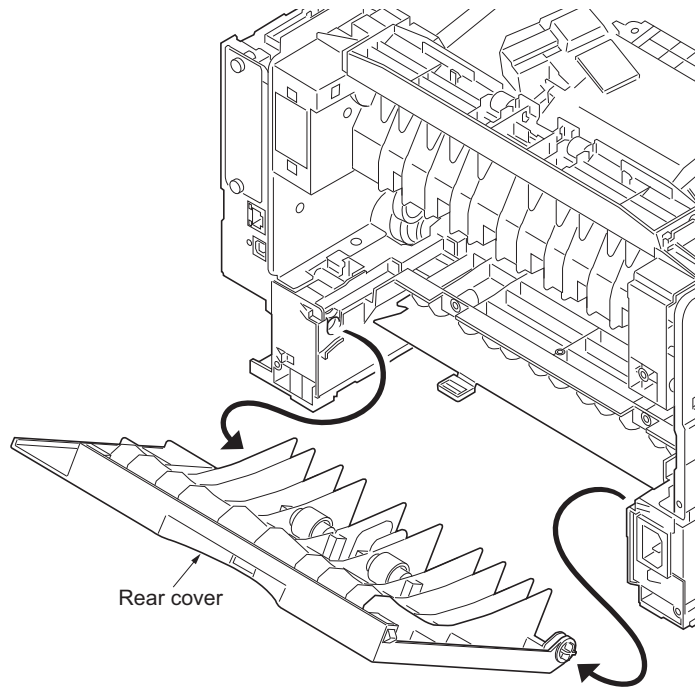

Figure 1-5-23

5. Open the rear cover and then remove the rear cover.



**Figure 1-5-24**

6. Remove two screws and then remove the fuser unit.
7. Check or replace the fuser unit and refit all the removed parts.

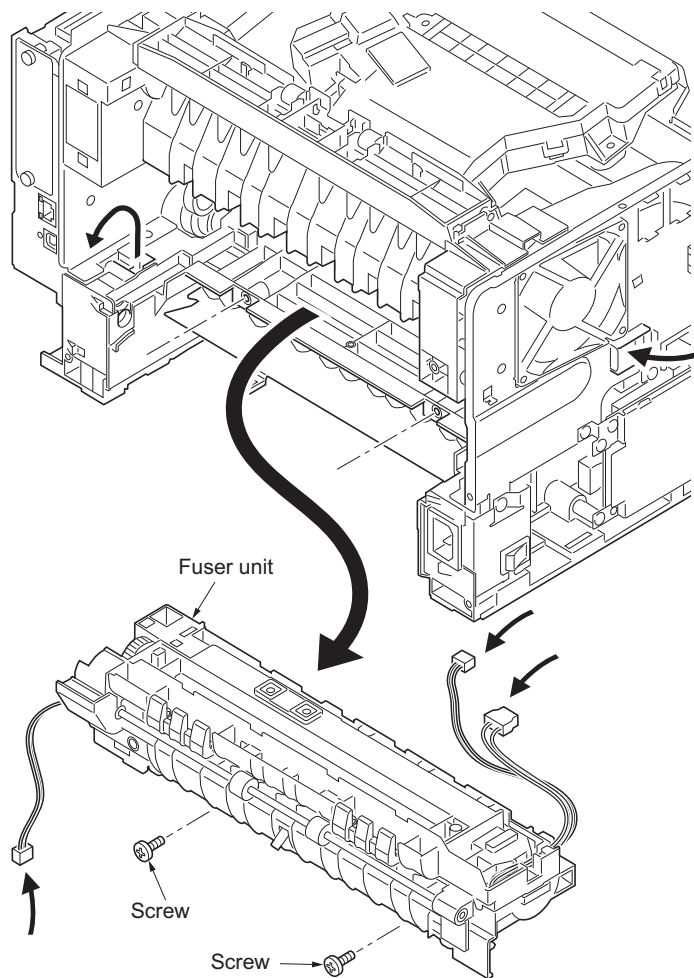

**Figure 1-5-25**

**(2) Switching the fuser pressure**

The fuser pressure may be decreased to suppress the print quality problems such as paper creases and curls. It must be cautioned that decreasing the fuser pressure could cause loose toner fusing.

**Procedure**

1. Remove the cassette (See page 1-5-6).
2. Open the duplex cover.
3. Slide the fuser lever R and L.

Normal:  
Flush with the front of the machine.

Fuser pressure decreased:  
Flush with the rear of the machine.

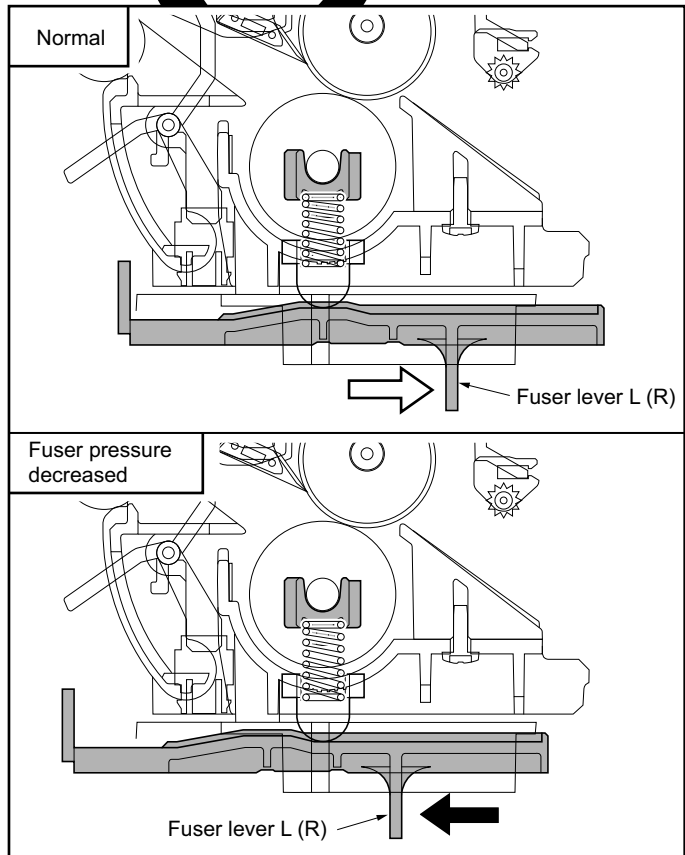
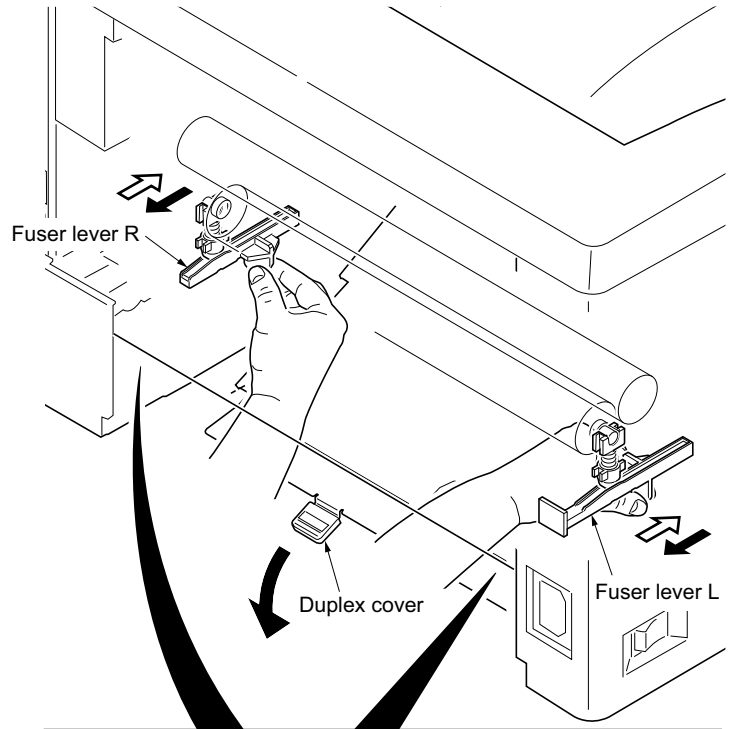

**Figure 1-5-26**



## 1-5-8 PWBs

### (1) Detaching and refitting the control PWB

#### Procedure

1. Remove the right cover (See page 1-5-4).
2. Remove the fourteen connectors from the control PWB.
3. Release the wires from the wire clamps.

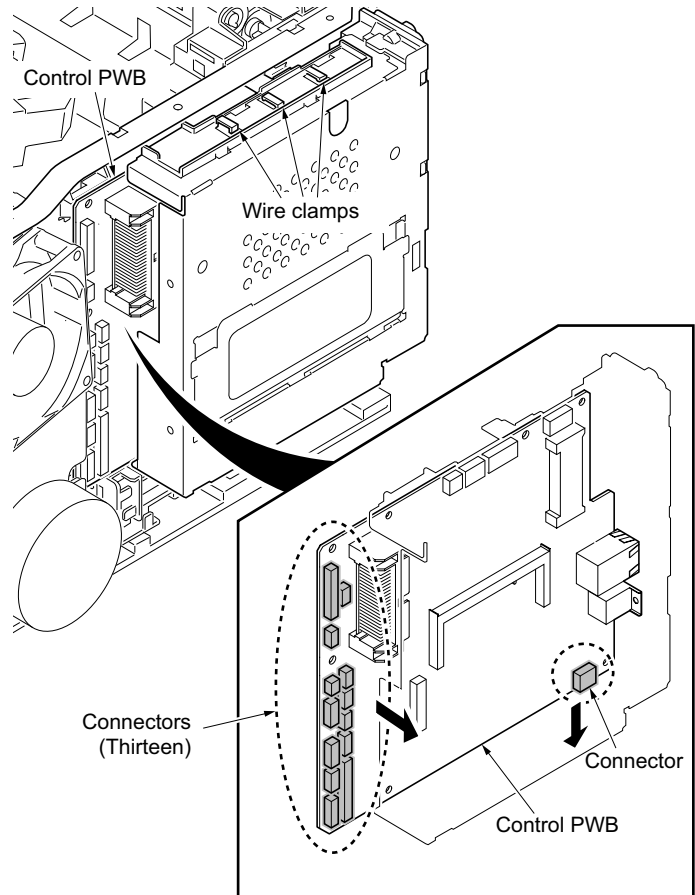

Figure 1-5-27

4. Remove five screws.
5. Remove the four connectors from the control PWB.
6. Unhook the hook and then remove the control PWB assembly.

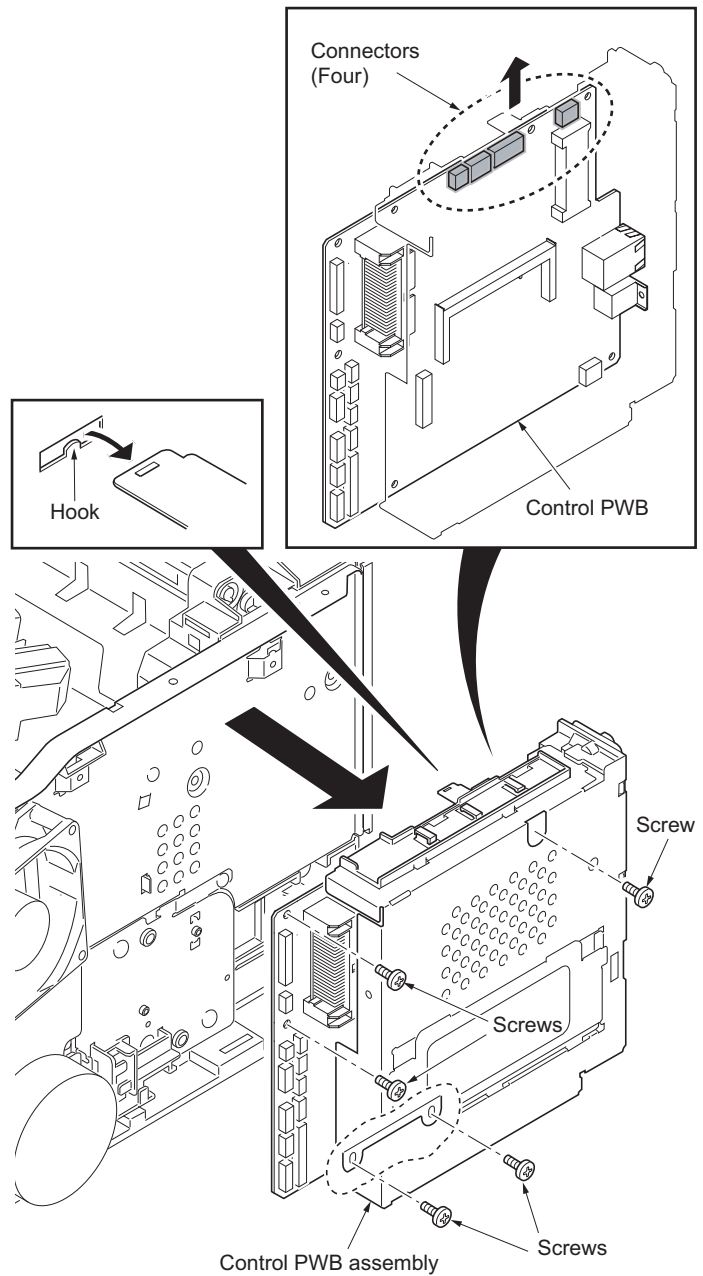
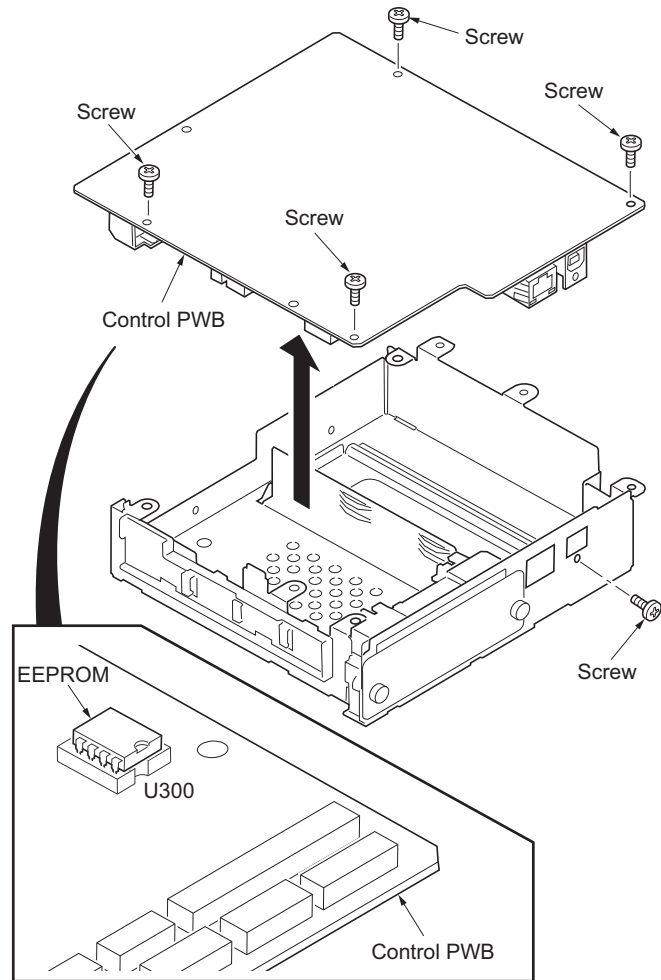

Figure 1-5-28

7. Remove five screws and then remove the control PWB.
8. Check or replace the control PWB and refit all the removed parts.  
To replace the control PWB, remove the EEPROM (U300) from the old control PWB and mount it to the new control PWB.

**Figure 1-5-29**

**(2) Detaching and refitting the power source PWB**

**Procedure**

1. Remove the left cover (See page 1-5-4).
2. Remove four connectors.

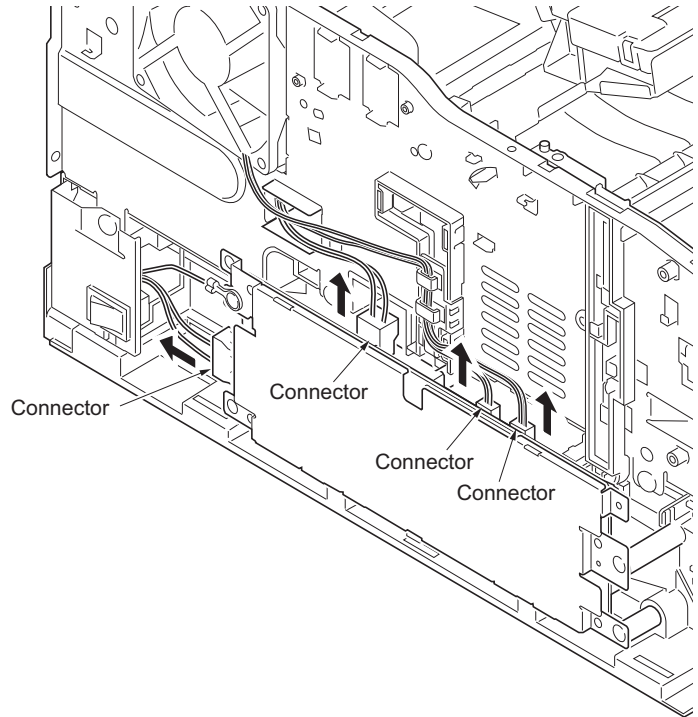

**Figure 1-5-30**

3. Remove four P tight screws, two screws and ground terminal.
4. Remove the power source PWB assembly from the high voltage PWB's connector.

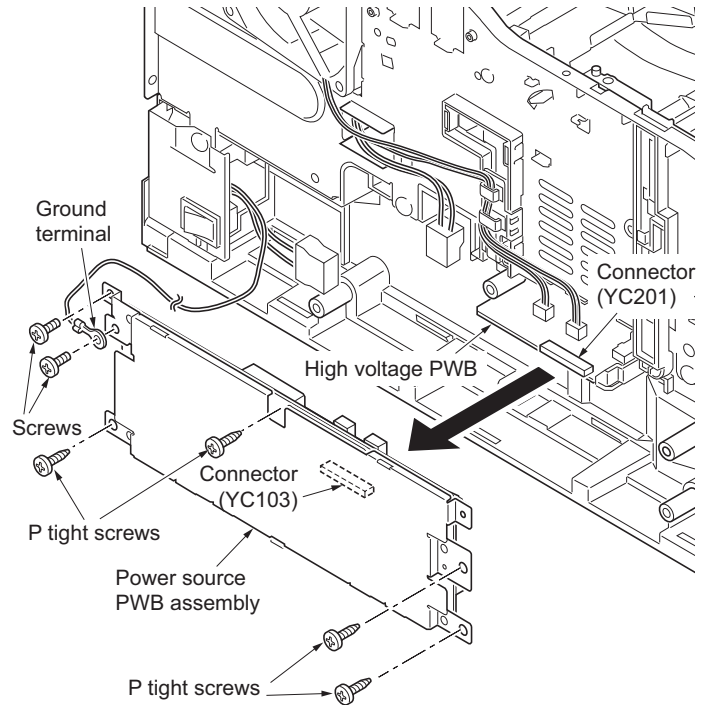

**Figure 1-5-31**

5. Remove four screws and then remove the power source plate from the power source PWB.
6. Check or replace the power source PWB and refit all the removed parts.  
Caution: The power source film must be installed in the specified position.

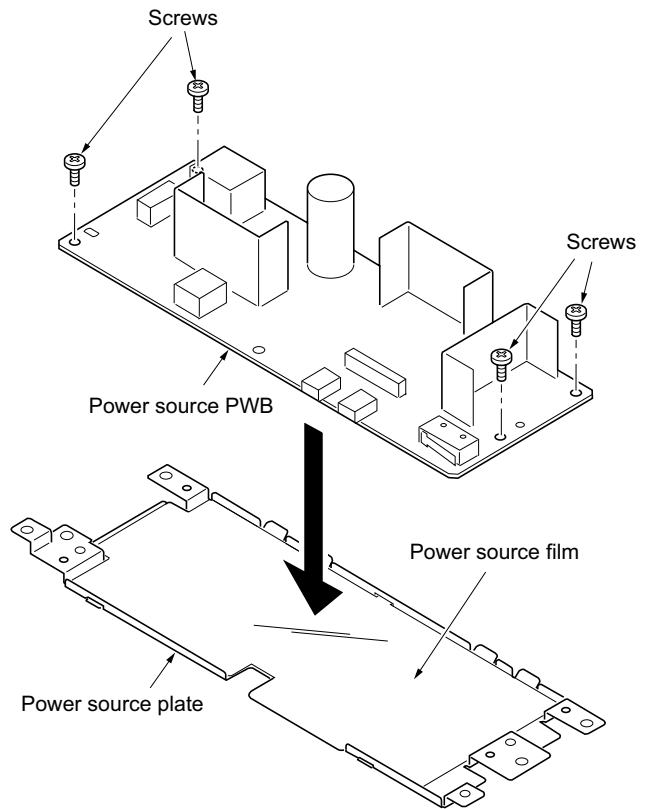

**Figure 1-5-32**

**(3) Detaching and refitting the high voltage PWB****Procedure**

1. Remove the developing unit (See page 1-5-11).
2. Remove the drum unit (See page 1-5-12).
3. Remove the cassette (See page 1-5-6).
4. Remove the outer covers (See page 1-5-3).
5. Remove the power source PWB (See page 1-5-22).
6. Turn the printer with the bottom side up.
7. Remove the stop ring.
8. Remove the DU holder.

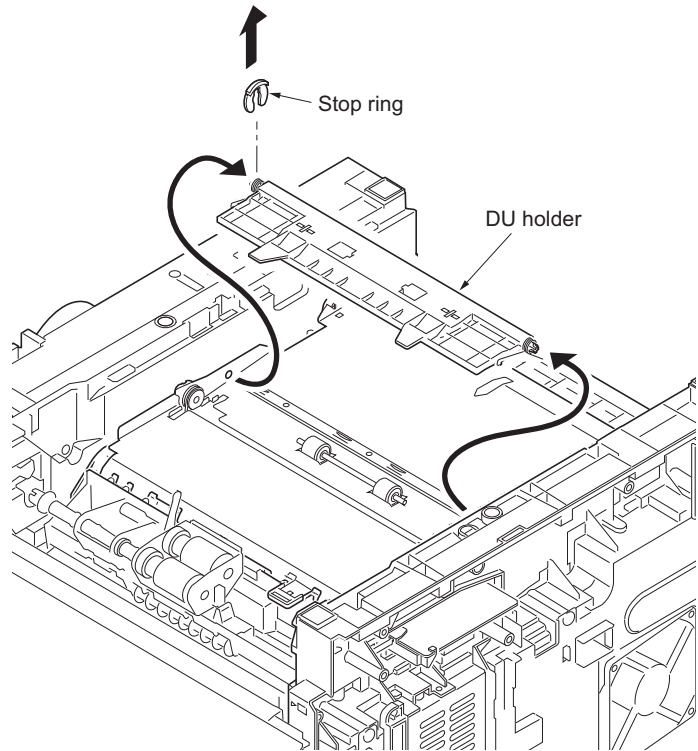
**Figure 1-5-33**

9. Pull out the DU bush.
10. Remove the DU cover assembly.

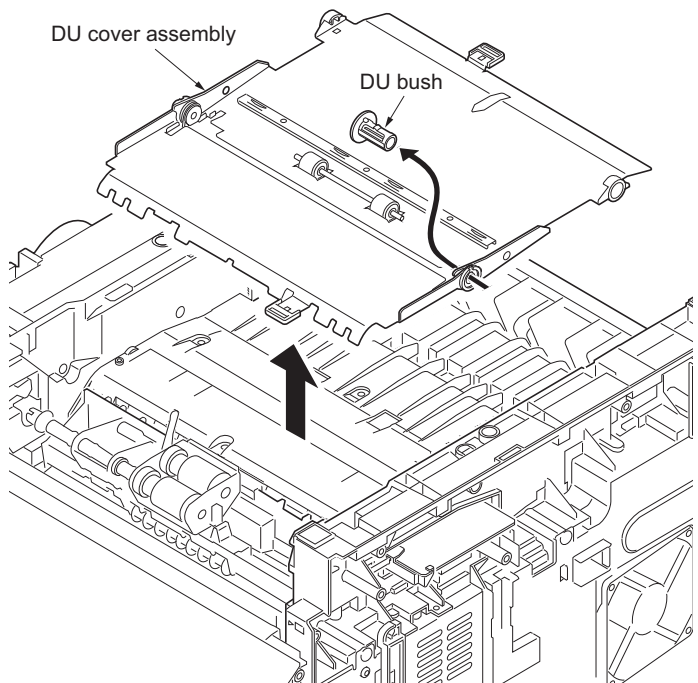
**Figure 1-5-34**

11. Remove four screws.
12. Unhook three hooks and then remove the lower base cover.

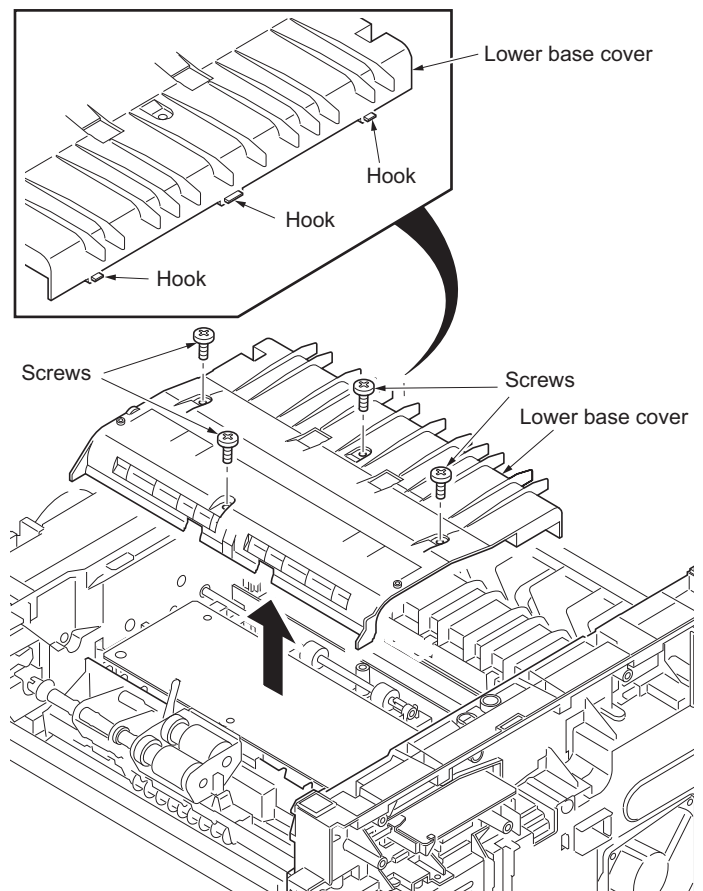

**Figure 1-5-35**

- 13. Remove the spring.
- 14. Remove the cassette pin.

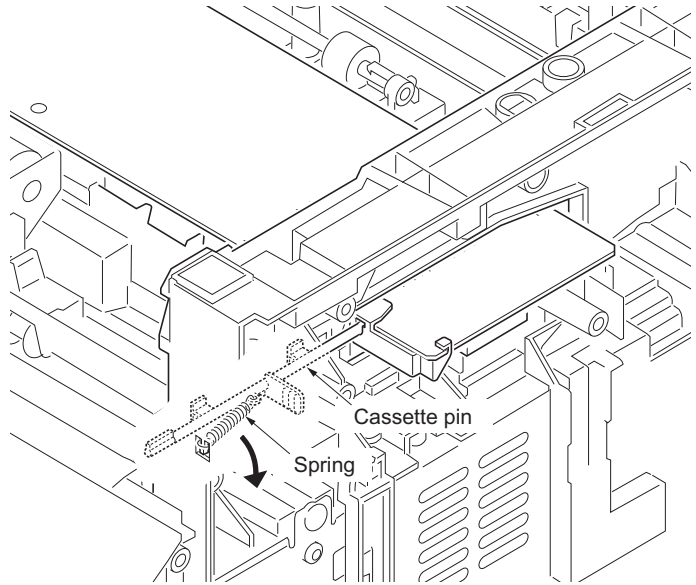

Figure 1-5-36

- 15. Remove two connectors and then remove the high voltage PWB.
- 16. Remove the cassette pin holder from the high voltage PWB.

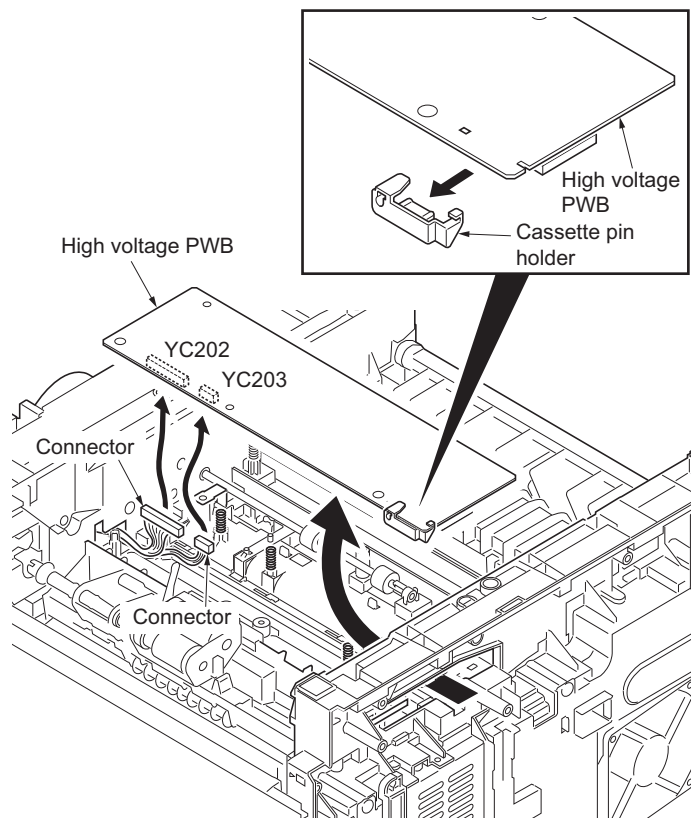

Figure 1-5-37



17. Check or replace the high voltage PWB and refit all the removed parts.

When refitting the high voltage PWB, be careful about following points.

- Position the ground plate so that it is atop the high voltage PWB.
- Each interface is firmly in contact with each spring.
- The bias contact pin must be installed in the specified position.
- The cassette pin must be inserted in the cassette pin holder.

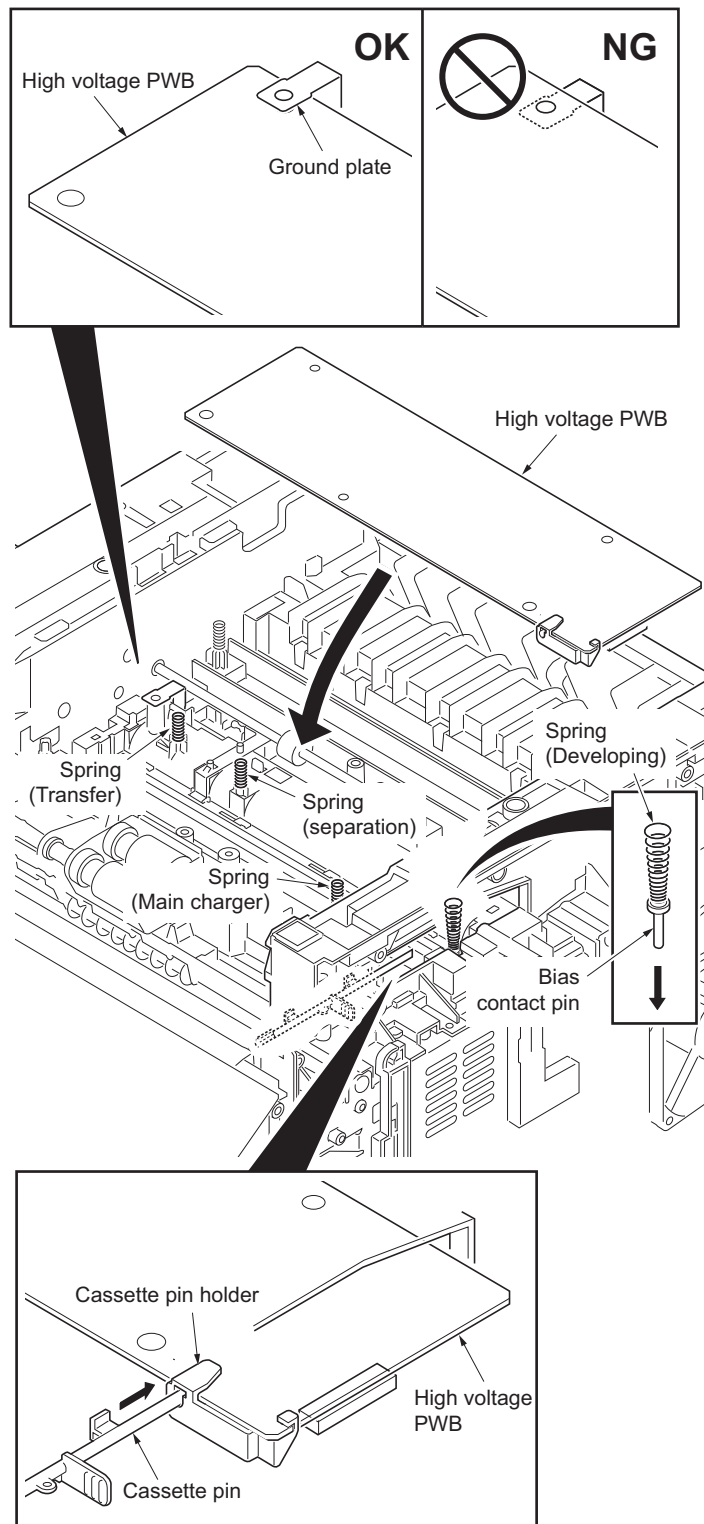

Figure 1-5-38

### 1-5-9 Others

#### (1) Detaching and refitting the main motor

##### Procedure

1. Remove the right cover (See page 1-5-4).
2. Remove the connector.

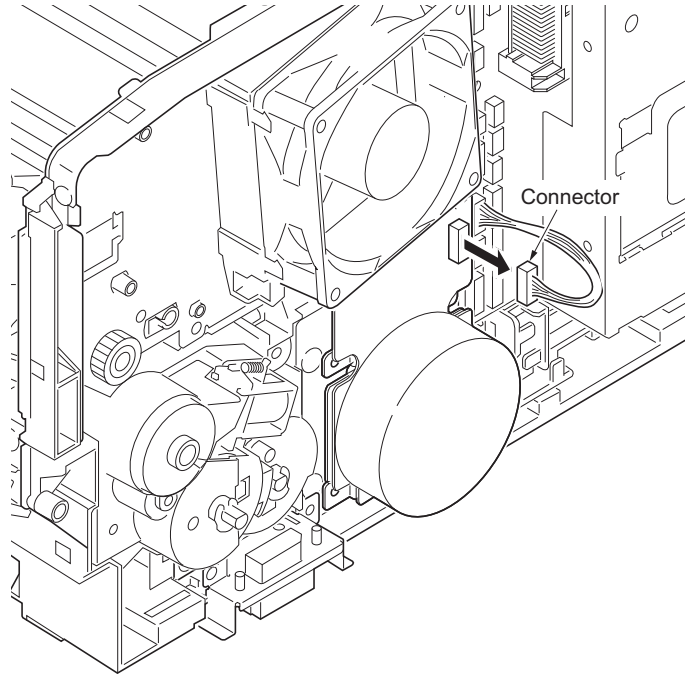

Figure 1-5-39

3. Remove the M3 screw and two M4 screws.
4. Remove the main motor.
5. Check or replace the main motor and refit all the removed parts.

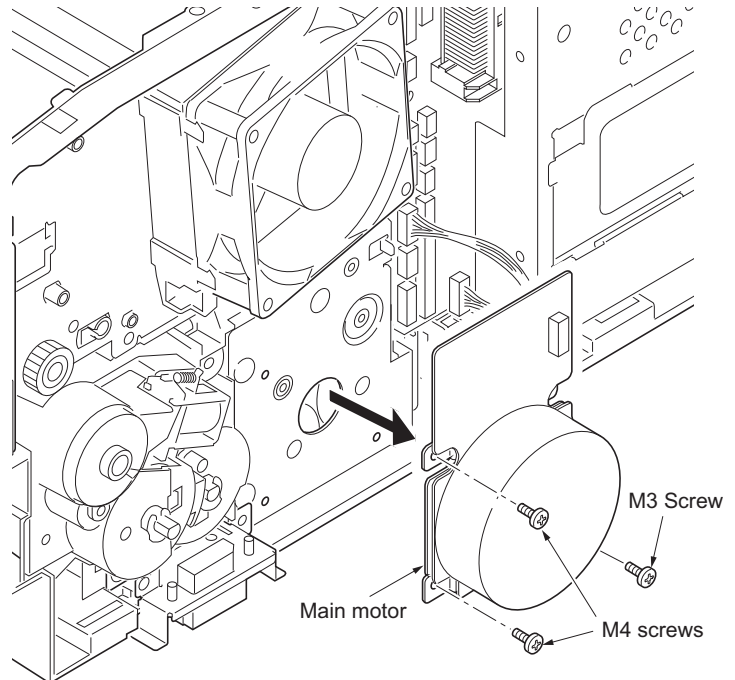
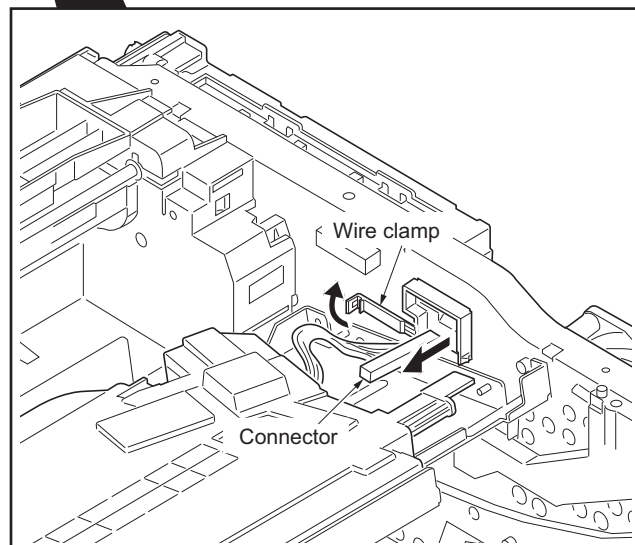
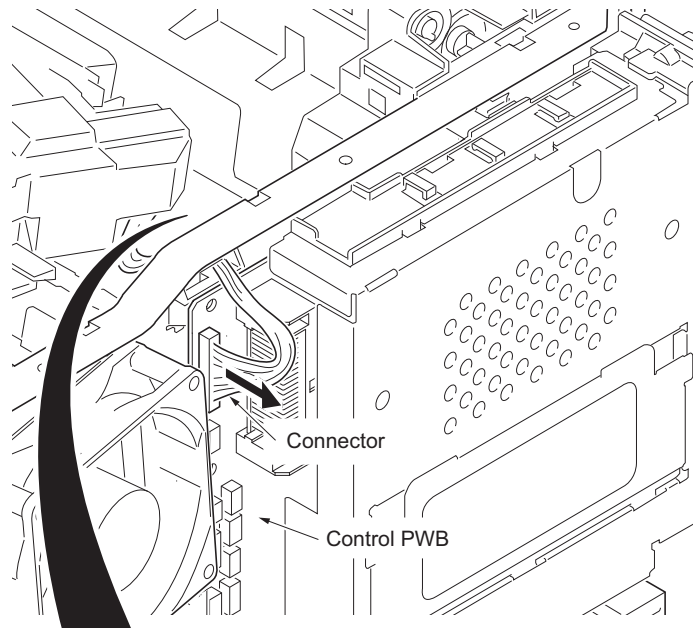

Figure 1-5-40

**(2) Detaching and refitting the laser scanner unit****Procedure**

1. Remove the right cover (See page 1-5-4).
2. Remove the connector from the control PWB.
3. Release the wire clamp.
4. Draw in the connector inside.

**Figure 1-5-41**

5. Remove four screws and then remove the laser scanner unit.
6. Check or replace the laser scanner unit and refit all the removed parts.

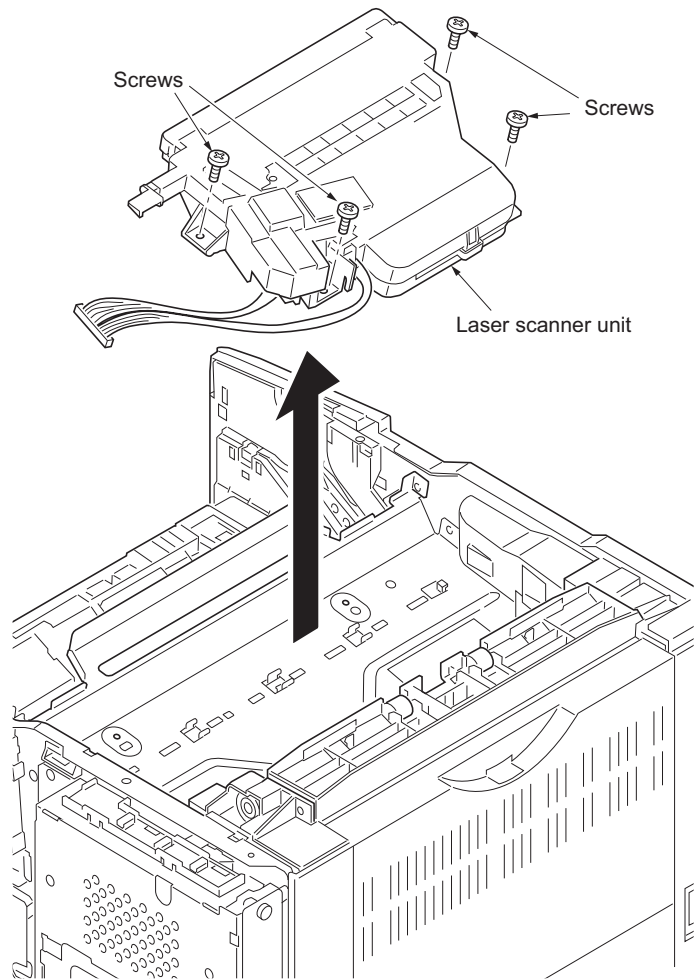
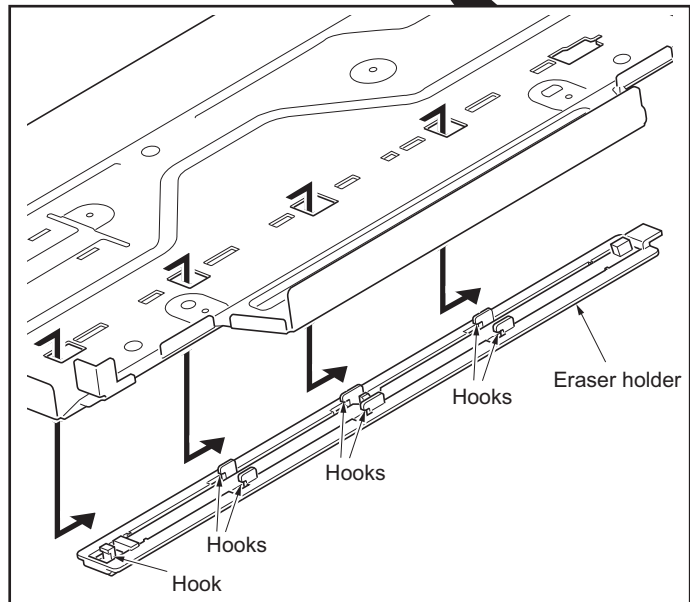
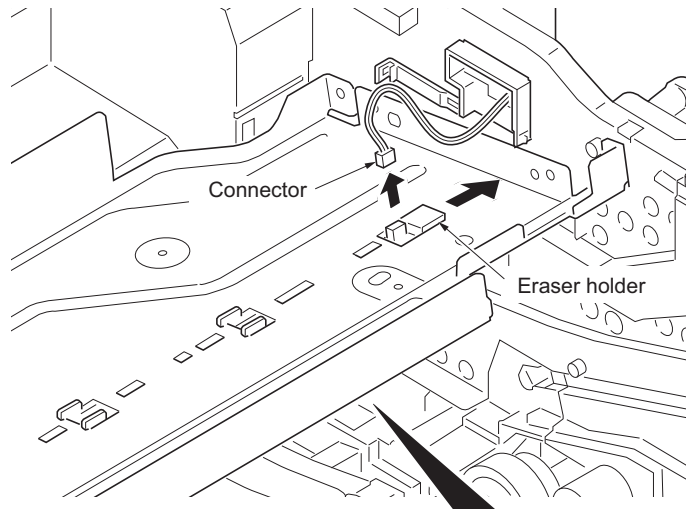

Figure 1-5-42

**(3) Detaching and refitting the eraser lamp (PWB)****Procedure**

1. Remove the laser scanner unit (See page 1-5-29).
2. Remove the connector.
3. Slide the eraser holder.
4. Unhook the hooks and then remove the eraser holder.

**Figure 1-5-43**

5. Remove the eraser lamp (PWB) from the eraser holder.
6. Check or replace the eraser lamp (PWB) and refit all the removed parts.

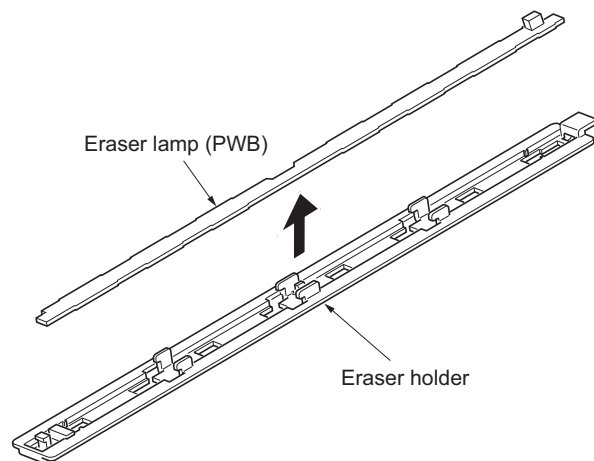
**Figure 1-5-44**

**(4) Direction of installing the left cooling fan motor and right cooling fan motor**

When detaching or refitting the left cooling fan motor or right cooling fan motor, be careful of the airflow direction (intake or exhaust).

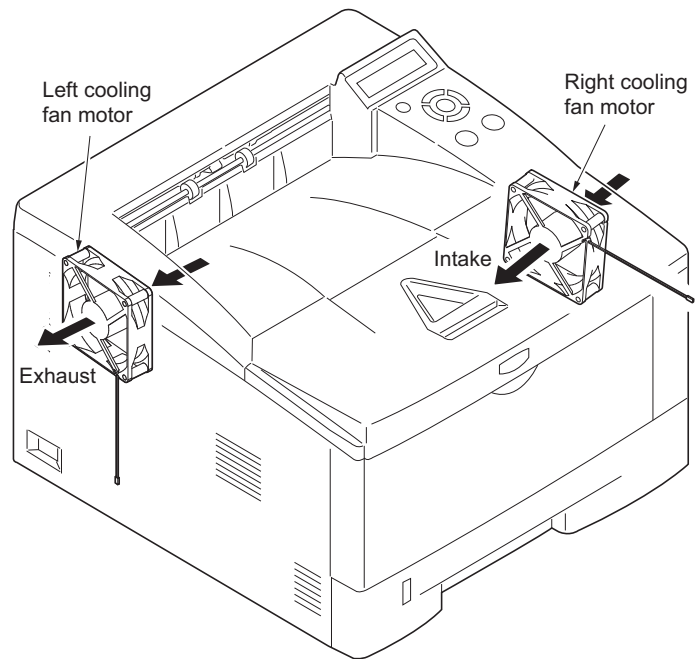

**Figure 1-5-45**

## 1-6-1 Downloading firmware

### (1) Firmware files

Firmware files are named after the following codes:

#### Firmware file name example

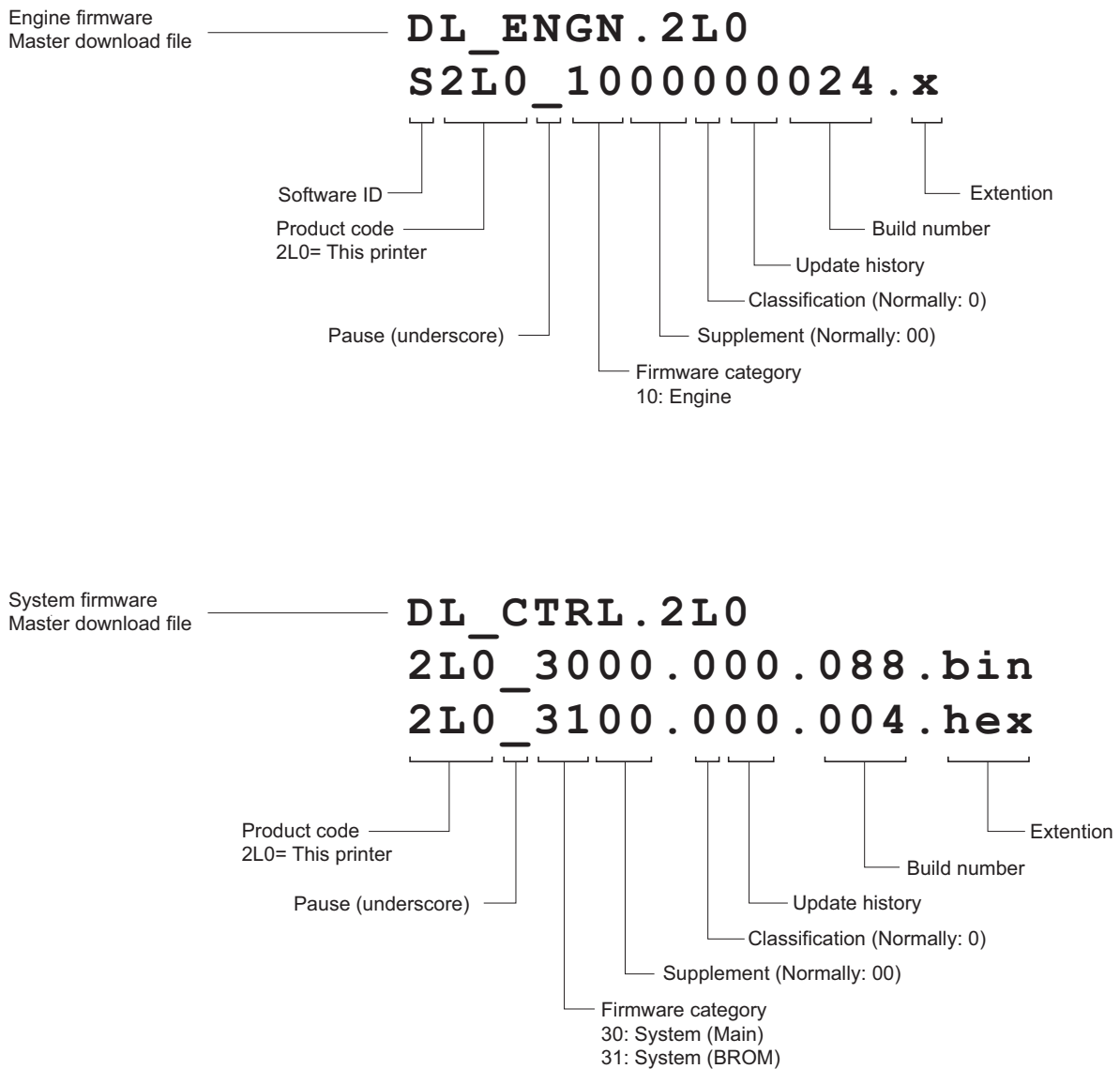

Figure 1-6-1

**(2) Downloading the firmware from the USB memory**

To download data written in a USB memory to the printer, proceed as explained in this section.

**CAUTION**

Downloading firmware takes several minutes. Do not turn power off during downloading. If downloading is interrupted by an accidental power failure, etc., the control PWB may have to be replaced.

**Procedure**

1. Turn printer power off.
2. Insert the USB memory to the PC's USB slot.
3. Copy the firmware files to download to the root directory of the USB memory.
4. Remove the USB memory from the PC's USB slot.
5. Insert the USB memory into the printer's USB memory slot.

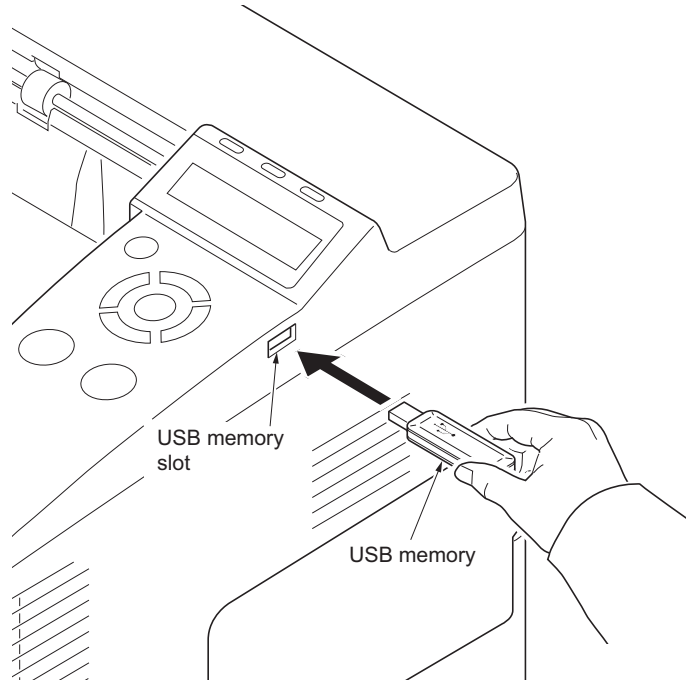

**Figure 1-6-2**

6. Turn printer power on.
7. When message display (1) is displayed to detect firmware in the USB memory.
8. Message display (2) is displayed during downloading.
9. When message display (3) is displayed to indicate downloading is finished.

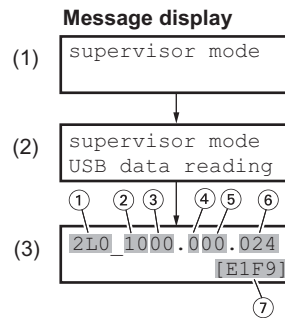

- ① Product code  
2L0: This printer
- ② Firmware category  
10: Engine  
30: System (Main)  
31: System (BROM)
- ③ Supplement (Normally: 00)
- ④ Classification (Normally: 0)
- ⑤ Update history
- ⑥ Build number
- ⑦ Checksum

**Figure 1-6-3**



10. Turn printer power off.
11. Remove the USB memory from USB memory slot.
12. Turn printer power on.
13. Print the service status page to check that the firmware version has been updated.  
(See page 1-3-7)

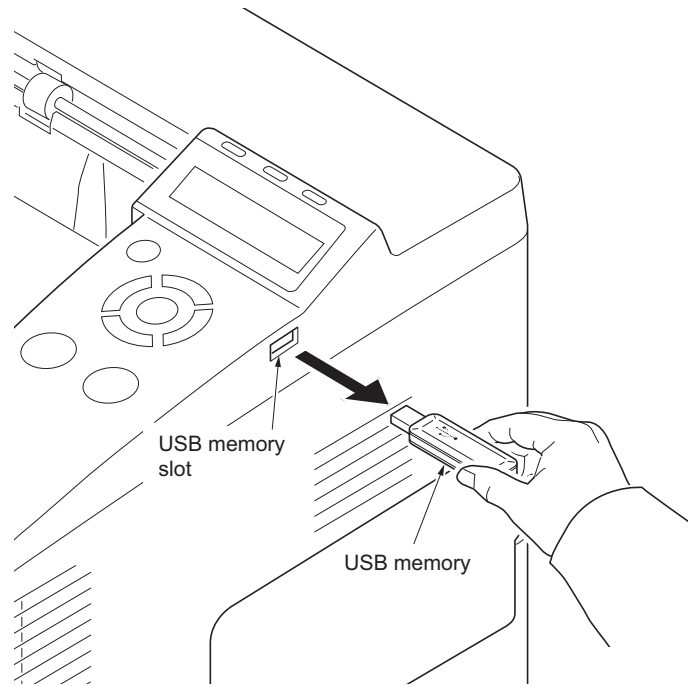

**Figure 1-6-4**

**(3) Downloading the firmware from the memory card**

To download data written in a memory card (CompactFlash) to the printer, proceed as explained in this section.

**CAUTION**

Downloading firmware takes several minutes. Do not turn power off during downloading. If downloading is interrupted by an accidental power failure, etc., the control PWB may have to be replaced.

**Procedure**

1. Turn printer power off.
2. Open the rear cover.
3. Remove two screws and then remove the optional interface slot cover.
4. Insert the memory card into the memory card slot.

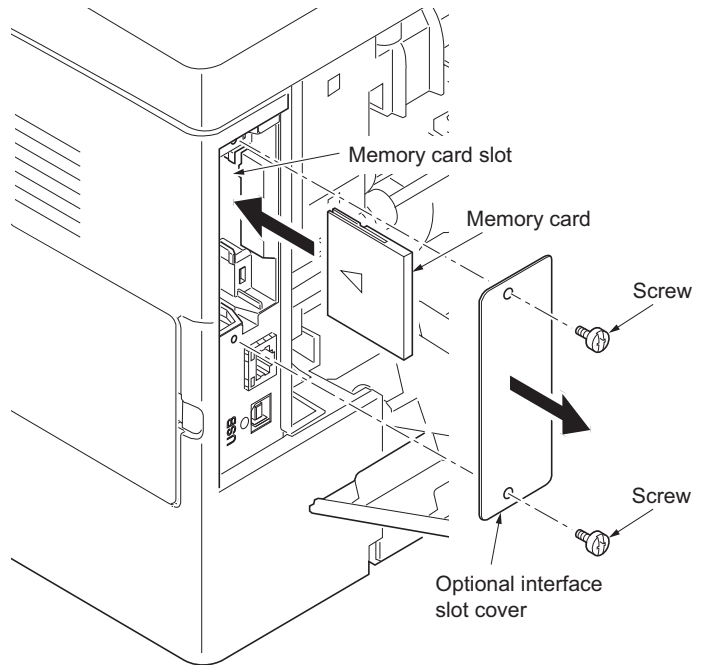

**Figure 1-6-5**

5. Turn printer power on.
6. Press MENU key on the printer's operation panel and carry out the memory card formatting procedure (1).
7. When formatting is complete, turn printer power off.

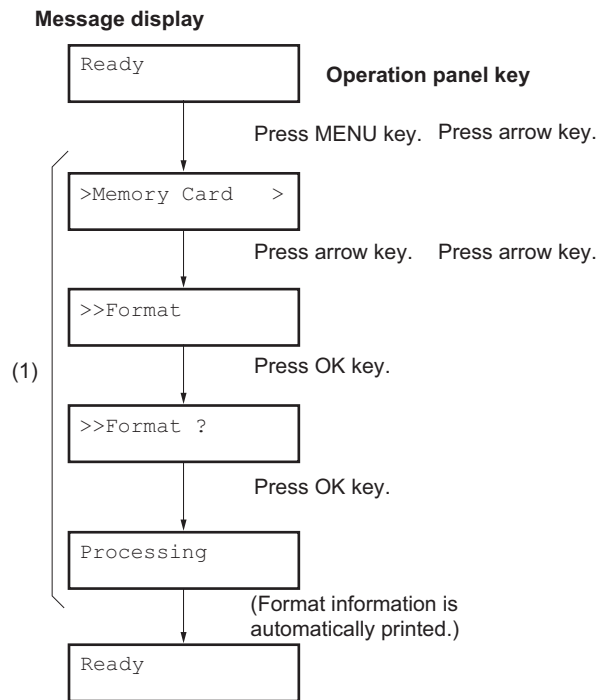

**Figure 1-6-6**

8. Remove the formatted memory card from the memory card slot.

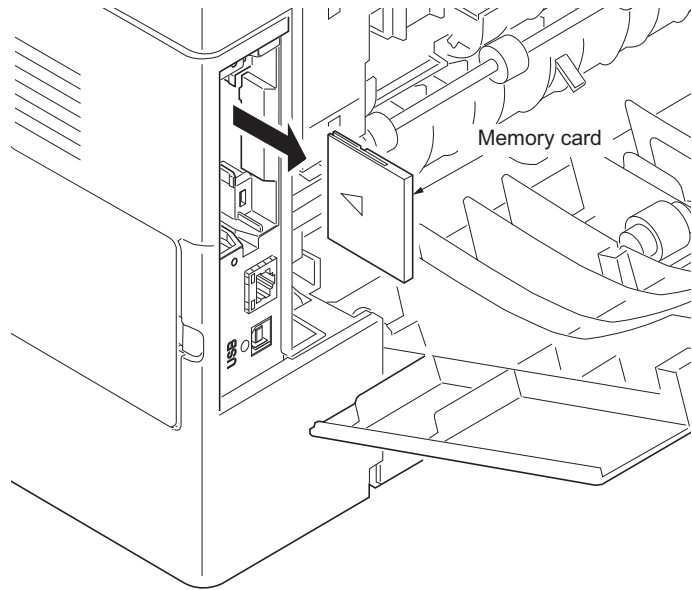

**Figure 1-6-7**

9. Insert the memory card to the PC's slot or to the adaptor.
10. Copy the firmware files to download to the root directory of the memory card.
11. Remove the memory card from the PC's slot or the adaptor.

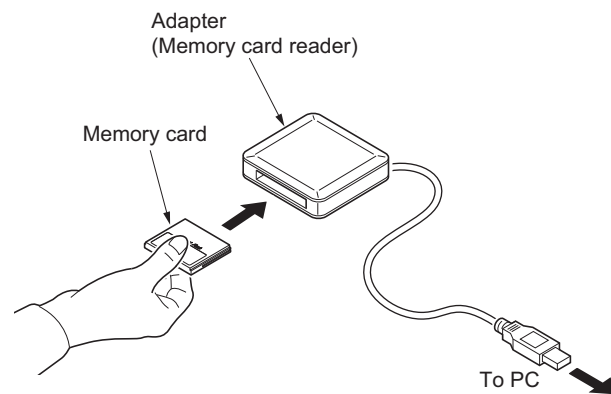

**Figure 1-6-8**

12. Insert the memory card into the memory card slot.

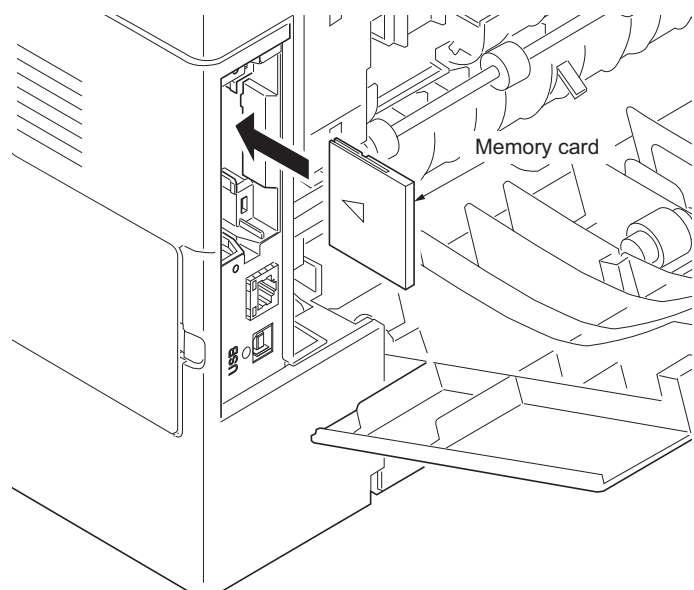

**Figure 1-6-9**

- 13. Turn printer power on.
- 14. When message display (1) is displayed to detect firmware in the memory card.
- 15. Message display (2) is displayed during downloading.
- 16. When message display (3) is displayed to indicate downloading is finished.

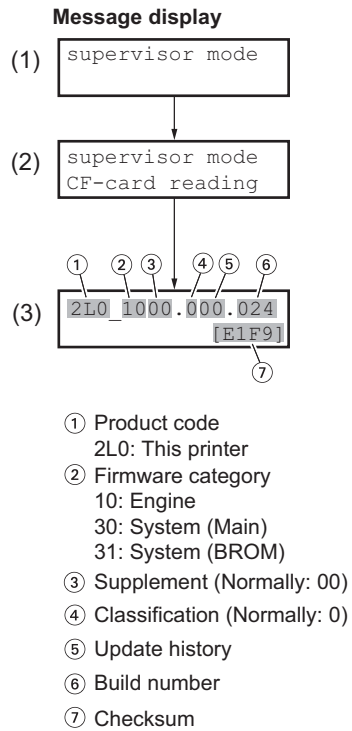

**Figure 1-6-10**

- 17. Turn printer power off.
- 18. Remove the memory card from memory card slot.
- 19. Refit the optional interface slot cover.
- 20. Turn printer power on.
- 21. Print the status page to check that the firmware version has been updated.  
(See page 1-3-7)

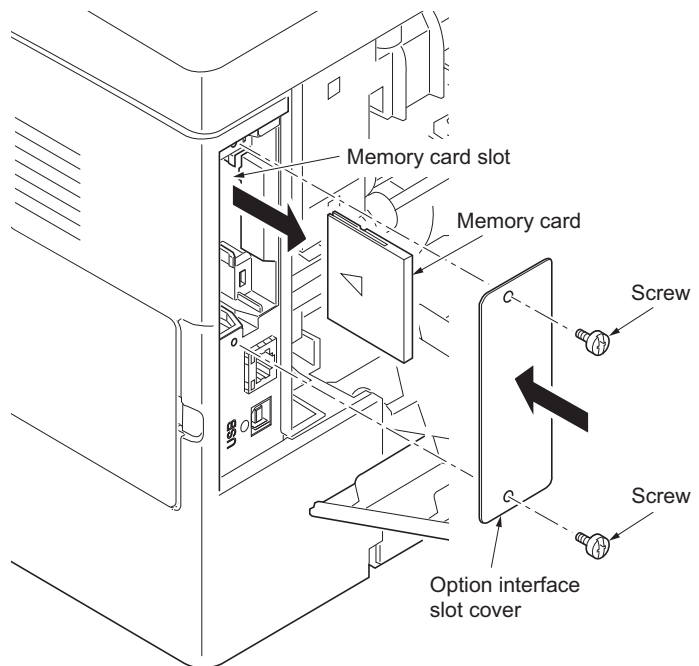
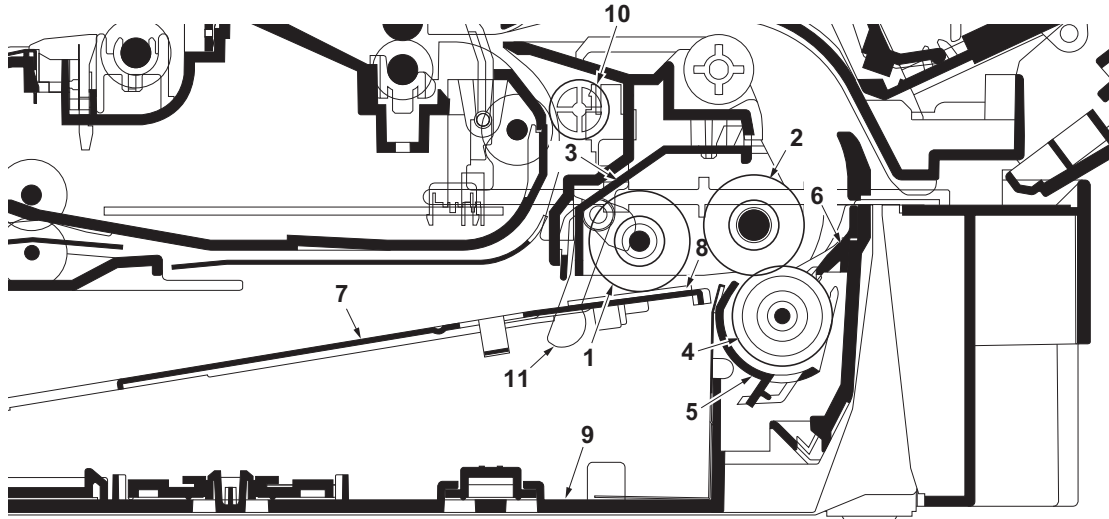

**Figure 1-6-11**

**2-1-1 Paper feed/conveying section**

Paper feed/conveying section consists of the paper feed unit that feeds paper from the cassette and the MP tray paper feed unit that feeds paper from the MP tray, and the paper conveying section that conveys the fed paper to the transfer/separation section.

**(1) Cassette paper feed section**



**Figure 2-1-1 Cassette paper feed section**

- |                       |                              |
|-----------------------|------------------------------|
| (1) Pickup roller     | (7) Bottom plate             |
| (2) Paper feed roller | (8) Bottom pad               |
| (3) Feed holder       | (9) Cassette base            |
| (4) Retard roller     | (10) Paper sensor            |
| (5) Retard holder     | (11) Actuator (paper sensor) |
| (6) Retard guide      |                              |

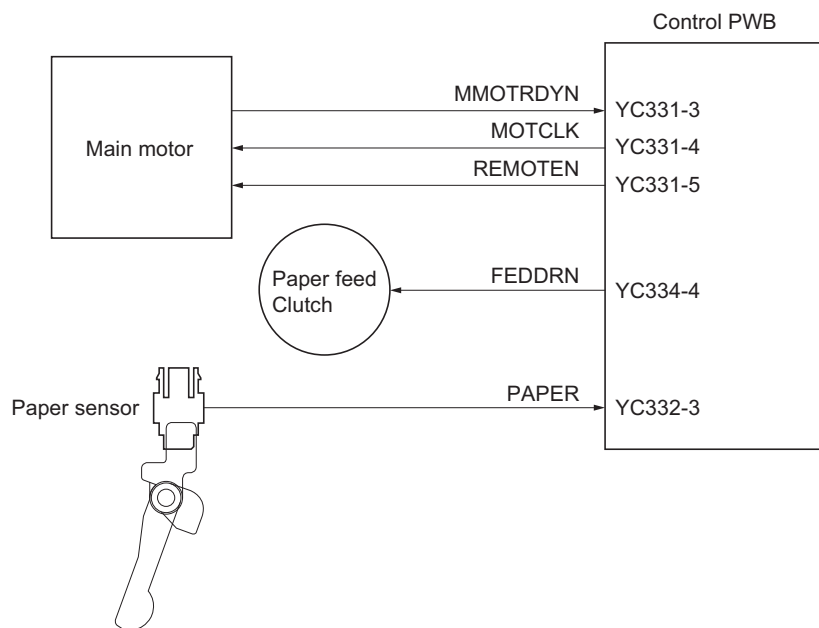

**Figure 2-1-2Cassette paper feed section block diagram**

(2) MP tray paper feed section

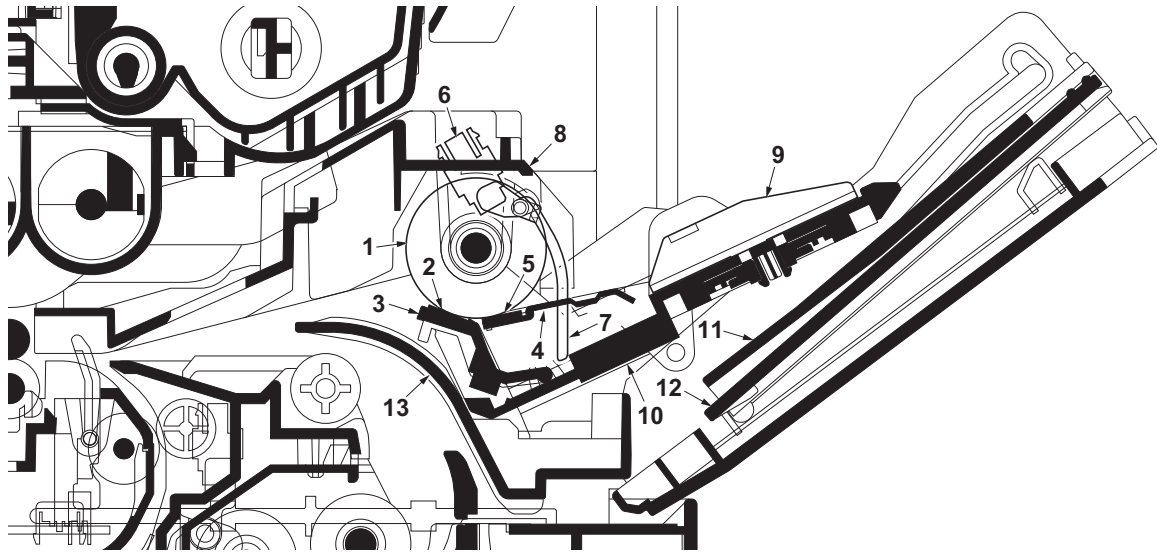

Figure 2-1-3 MP tray paper feed section

- |                                |                      |
|--------------------------------|----------------------|
| (1) MP paper feed roller       | (8) MPF frame        |
| (2) MPF separation pad         | (9) MPF guide R/L    |
| (3) MPF separator              | (10) MPF base        |
| (4) MPF bottom plate           | (11) MPF middle tray |
| (5) MPF friction pad           | (12) MPF upper tray  |
| (6) MP paper sensor            | (13) MPF turn guide  |
| (7) Actuator (MP paper sensor) |                      |

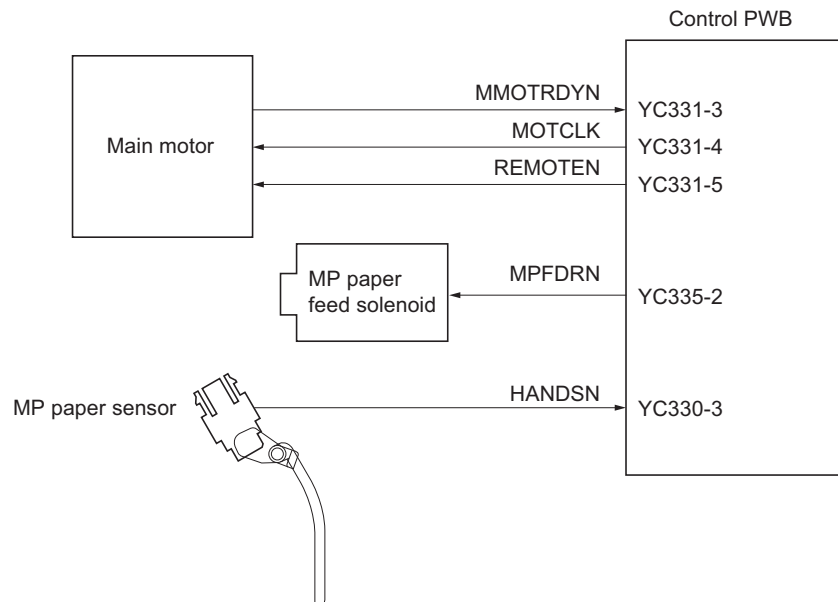

Figure 2-1-4 MP tray paper feed section block diagram

(3) Paper conveying section

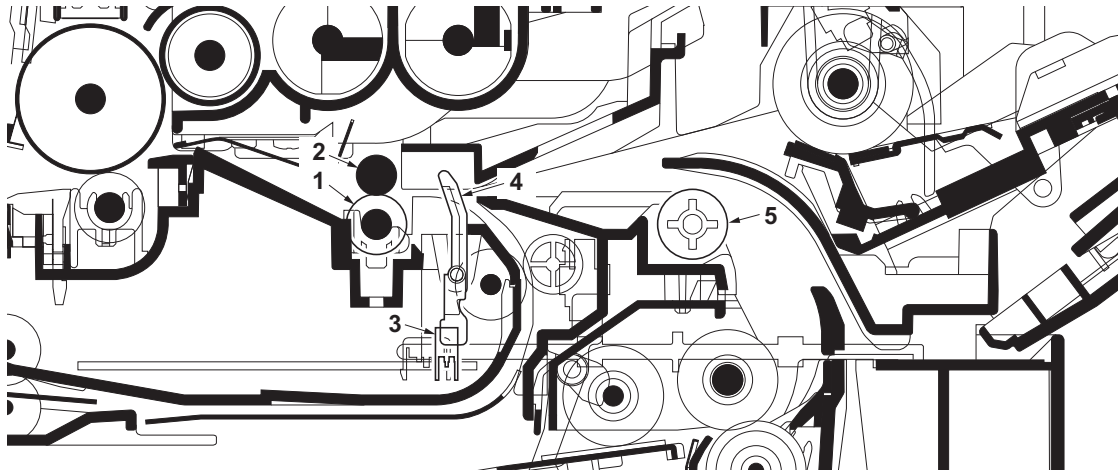

Figure 2-1-5 Paper conveying section

- (1) Lower registration roller
- (2) Upper registration roller
- (3) Registration sensor
- (4) Actuator (registration sensor)
- (5) Feed pulley

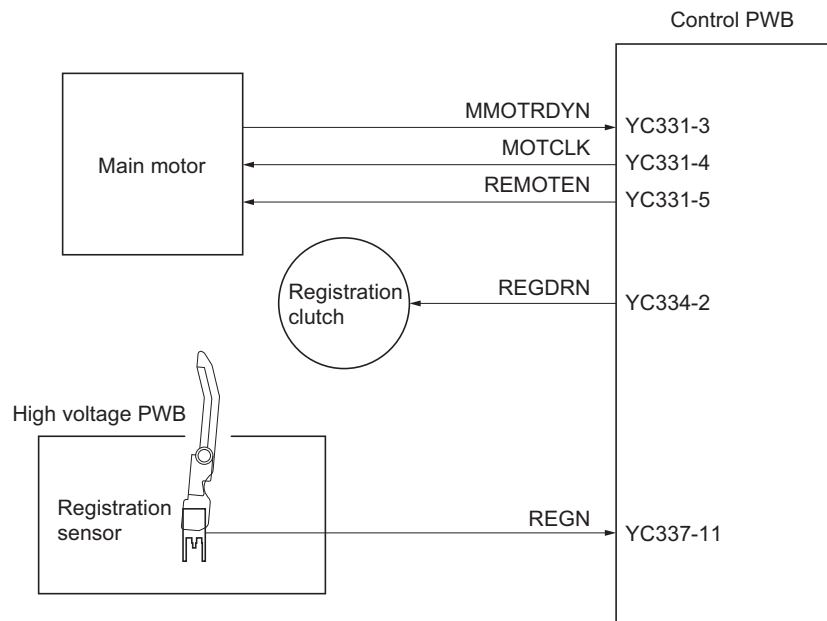

Figure 2-1-6 Paper conveying section block diagram

## 2-1-2 Drum section

### (1) Drum section

The durable layer of organic photoconductor (OPC) is coated over the aluminum cylinder base. The OPC tend to reduce its own electrical conductance when exposed to light. After a cyclic process of charging, exposure, and development, the electrostatic image is constituted over the OPC layer.

Since the OPC is materialized by resin, it is susceptible to damage caused by sharp edges such as a screwdriver, etc., resulting in a print quality problem. Also, finger prints can cause deterioration of the OPC layer, therefore, the drum (in the drum unit) must be handled with care. Substances like water, alcohol, organic solvent, etc., should be strictly avoided.

As with all other OPC drums, the exposure to a strong light source for a prolonged period can cause a print quality problem. The limit is approximately 500 lux for less than five minutes. If the drum (drum unit) remains removed from the printer, it should be stored in a cool, dark place.

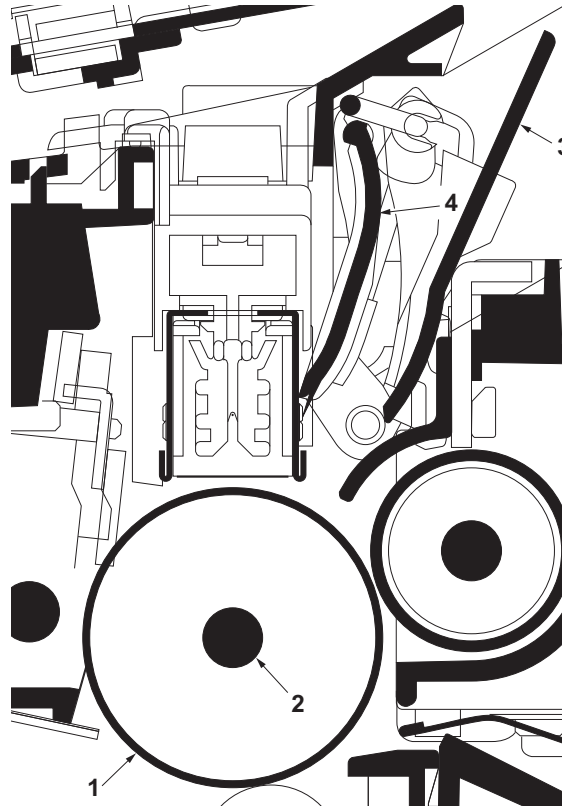

Figure 2-1-7 Drum section

- (1) Drum
- (2) Drum shaft
- (3) Drum cover A
- (4) Drum cover B



## (2) Main charger unit

As the drum rotates in a “clean (neutral)” state, its photoconductive layer is given a uniform, positive (+) corona charge dispersed by the main charger wire. Due to high-voltage scorotron charging, the charging wire can get contaminated by oxidation after a long run. Therefore, the charger wire must be cleaned at a specific interval. Cleaning the charging wire prevents print quality problems such as black streaks.

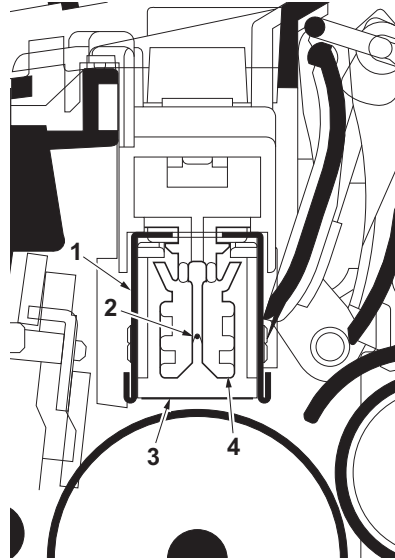

**Figure 2-1-8 Main charger unit**

- (1) Main charger shield
- (2) Main charger wire
- (3) Main charger grid
- (4) Main charger wire cleaner

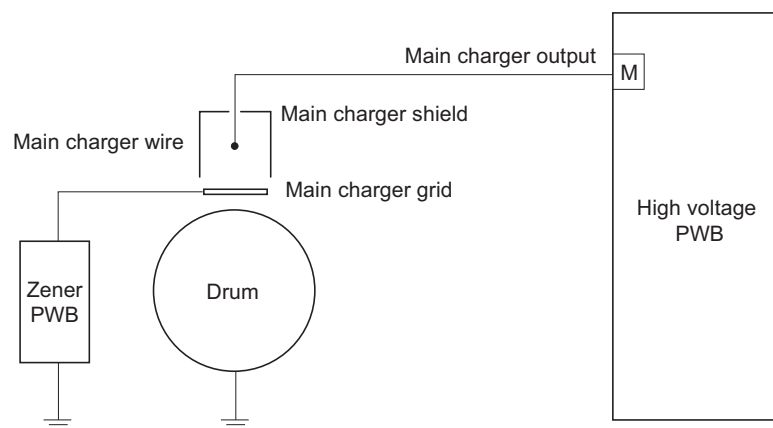

**Figure 2-1-9 Drum unit and main charger unit block diagram**

### 2-1-3 Optical section

#### (1) Laser scanner unit

The charged surface of the drum is then scanned by the laser beam from the laser scanner unit.

The laser beam (780 nm wavelength) beam is dispersed as the polygon motor revolves to reflect the laser beam over the drum. Various lenses and mirror are housed in the laser scanner unit, adjust the diameter of the laser beam, and focalize it at the drum surface.

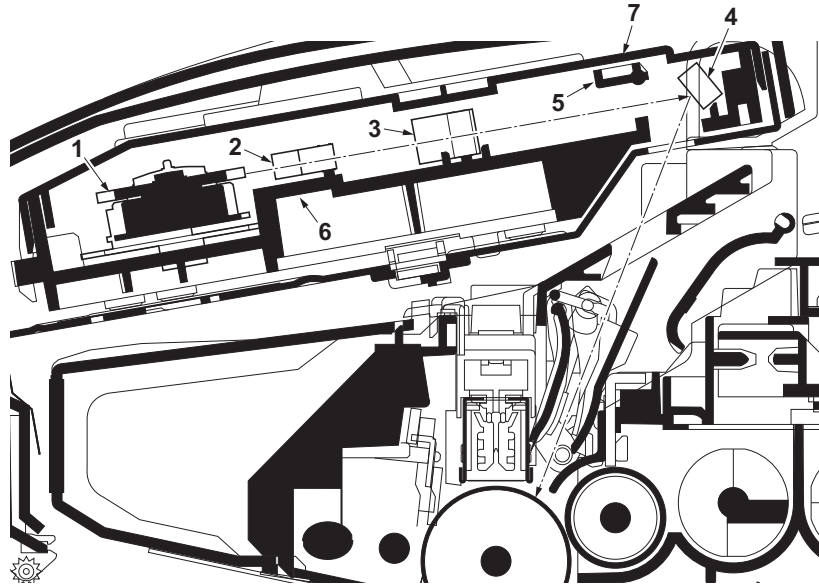

**Figure 2-1-10 Laser scanner unit**

- (1) Polygon motor (mirror)
- (2) F- $\theta$  lens
- (3) F- $\theta$  lens
- (4) LSU mirror
- (5) LSU shutter
- (6) LSU frame
- (7) LSU cover

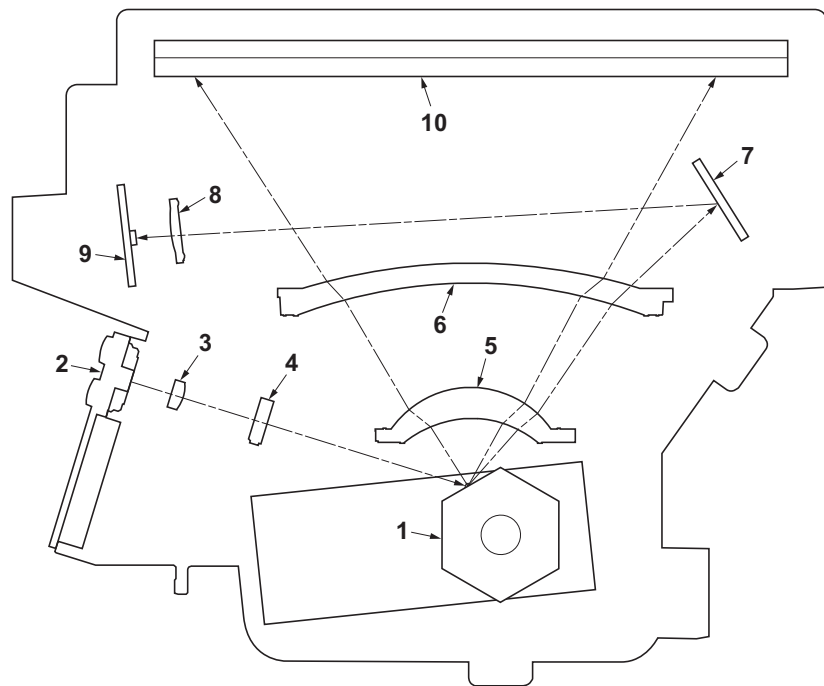

**Figure 2-1-11 Laser scanner unit**

- (1) Polygon motor (mirror)
- (2) Laser diode (APC PWB)
- (3) Collimator lens
- (4) Cylindrical lens
- (5) F-θ lens
- (6) F-θ lens
- (7) PD mirror
- (8) SOS lens
- (9) Pin photo diode sensor (PD PWB)
- (10) LSU mirror

**2-1-4 Developing section**

The latent image constituted on the drum is developed into a visible image. The developing roller contains a 3-pole (S-N-S) magnet roller and an aluminum cylinder rotating around the magnet roller. Toner attracts to the magnet sleeve since it is powdery ink made of black resin bound to iron particles. Developing blade, magnetized by magnet, is positioned approximately 0.3 mm above the magnet sleeve to constitute a smooth layer of toner in accordance with the magnet sleeve revolution.

The developing roller is applied with the AC-weighted, positive DC power source. Toner on the magnet sleeve is given a positive charge. The positively charged toner is then attracted to the areas of the drum which was exposed to the laser light. (The gap between the drum and the magnet sleeve is approximately 0.32 mm.) The non-exposed areas of the drum repel the positively charged toner as these areas maintain the positive charge.

The developing roller is also AC-biased to ensure contrast in yielding by compensating the toner's attraction and repelling action during development.

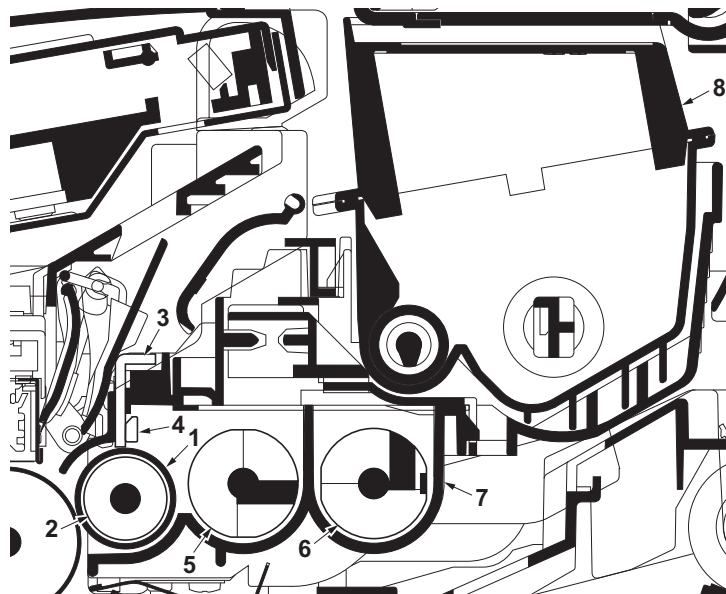

**Figure 2-1-12 Developing unit and toner container**

- |                      |                     |
|----------------------|---------------------|
| (1) Magnet sleeve    | (5) DLP screw A     |
| (2) Magnet roller    | (6) DLP screw B     |
| (3) Developing blade | (7) DLP case        |
| (4) Blade magnet     | (8) Toner container |

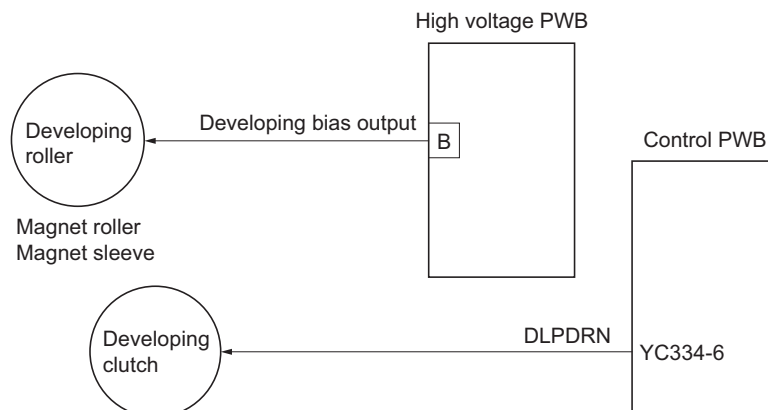

**Figure 2-1-13 Developing section block diagram**

### 2-1-5 Transfer/separation section

The transfer/separation section consists of the transfer roller, discharger brush and paper chute guide. A high voltage generated by the high voltage PWB is applied to the transfer roller for transfer charging. Paper after transfer is separated from the drum.

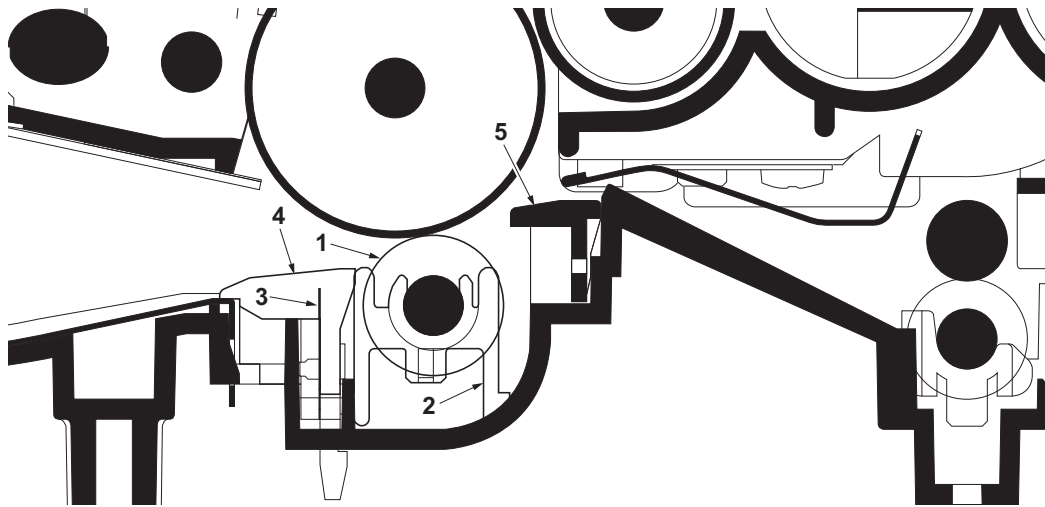

**Figure 2-1-14 Transfer/separation section**

- (1) Transfer roller
- (2) Transfer bushes
- (3) Discharger brush
- (4) DC brush holder
- (5) Paper chute guide

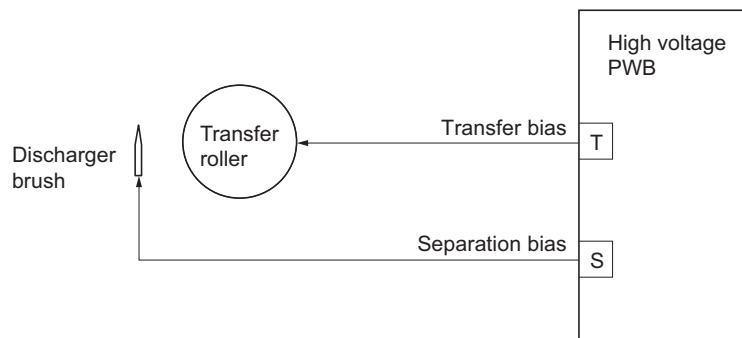
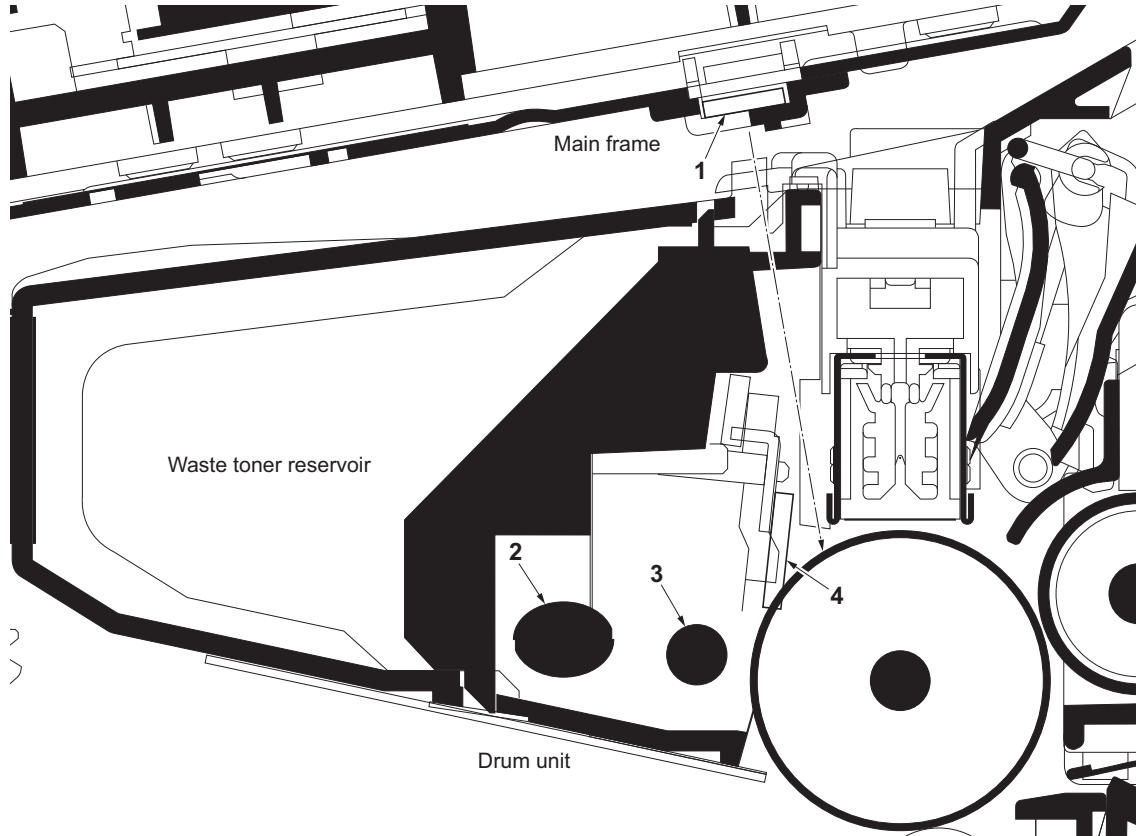

**Figure 2-1-15 Transfer/separation section block diagram**

**2-1-6 Cleaning section**

After the transferring process, the drum needs to be physically cleaned of toner which is residual after the development process. The cleaning blade is constantly pressed against the drum and scrapes the residual toner off to the sweep roller. The waste toner is collected at the output end of the sweep roller and sent back to the toner container, into the waste toner reservoir.

After the drum is physically cleaned, it then must be cleaned to the electrically neutral state. This is necessary to erase any residual positive charge, ready to accept the uniform charge for the next print process. The residual charge is canceled by exposing the drum to the light emitted from the eraser lamp (PWB). This lowers the electrical conductivity of the drum surface making the residual charge on the drum surface escape to the ground.



**Figure 2-1-16 Cleaning section**

- (1) Eraser lamp (PWB)
- (2) Sweep roller
- (3) Toner conveying roller
- (4) Cleaning blade

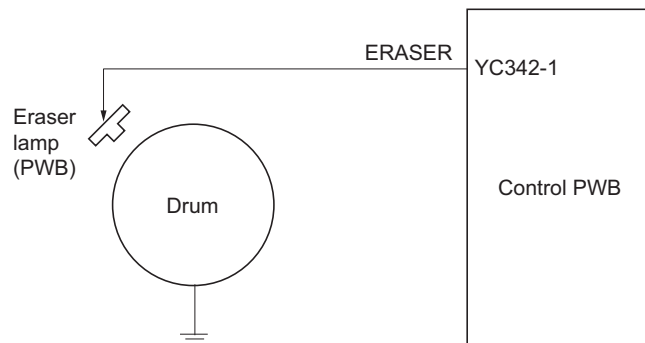

**Figure 2-1-17 Cleaning section block diagram**

### 2-1-7 Fuser section

The toner on the paper is molten and pressed into the paper as it passes between the heat roller and the press roller in the fuser unit. The heat roller has a heater lamp inside which continuously turns on and off by the fuser thermistor to maintain the constant temperature onto the heat roller surface. The heat roller is resin coated by fluorin to prevent toner from accumulating on the roller after a long run. Care must be taken while handling the heat roller not to scratch the roller surface as doing so may result in print problems. Fuser temperature is optimized to the paper type. The heat roller has four separators (claws) which are continuously in contact with its surface. These separators (claws) prevent the paper on which toner has been fused from being wound around the heat roller causing paper jam. The press roller is made of the heat-resistant silicon rubber. This roller is used to strongly press the paper towards the heat roller by means of press springs. The temperature of the heat roller is constantly monitored by the control PWB using the fuser thermistor. Should the temperature of the heat roller exceed the predetermined value, the fuser thermal cutout is activated to effectively disconnect the heater lamp from power.

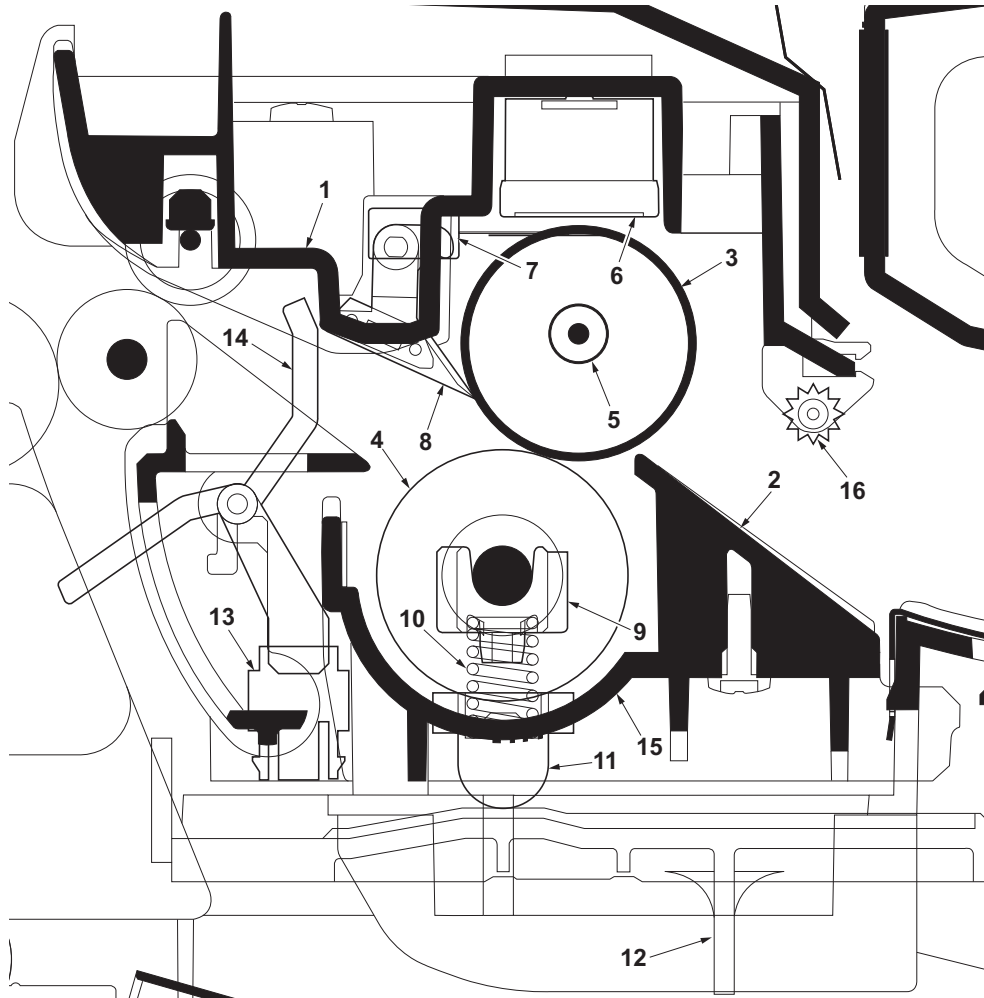

Figure 2-1-18 Fuser section

- |                          |                             |
|--------------------------|-----------------------------|
| (1) Upper fuser frame    | (9) Fuser bushes            |
| (2) Lower fuser frame    | (10) Press springs          |
| (3) Heat roller          | (11) Press spring holders   |
| (4) Press roller         | (12) Fuser lever L (R)      |
| (5) Fuser heater lamp    | (13) Exit sensor            |
| (6) Fuser thermal cutout | (14) Actuator (exit sensor) |
| (7) Fuser thermistor     | (15) Fuser guide            |
| (8) Separators           | (16) Fuser guide pulley     |

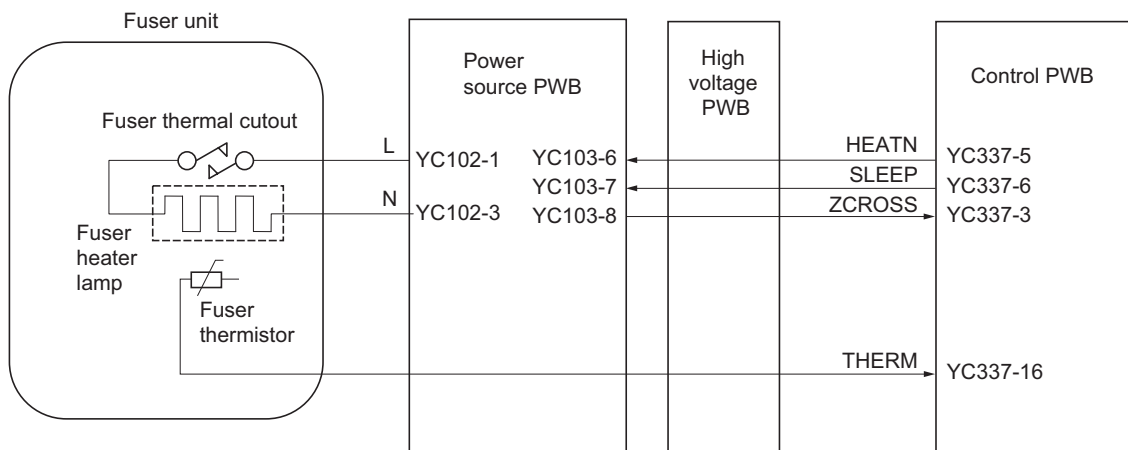
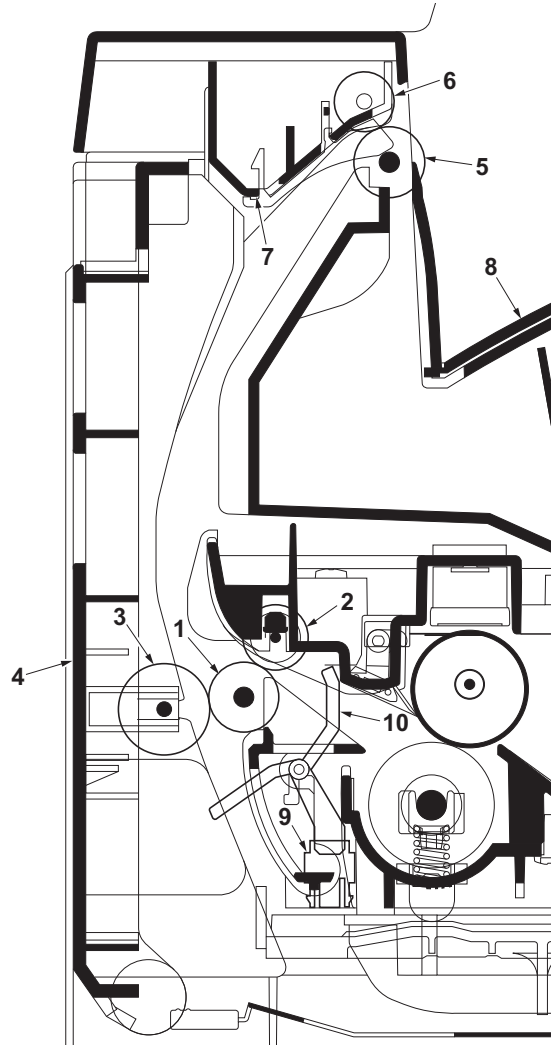

Figure 2-1-19 Fuser section block diagram



### 2-1-8 Paper exit section

The paper exit section transports the paper which passed the fuser unit towards the top tray. The paper which passed through the fuser unit turns on the actuator (exit sensor) in the fuser unit, and is led by the guide comprised of the rear cover, frame and the FD cover guide, finally reaching the FD roller. The paper is delivered to the top tray by the rotation of the FD roller.



**Figure 2-1-20 Paper exit section**

- (1) Exit roller
- (2) Fuser exit pulley
- (3) Middle pulley
- (4) Rear cover
- (5) FD roller
- (6) Exit pulley
- (7) FD cover
- (8) Top tray
- (9) Exit sensor
- (10) Actuator (exit sensor)

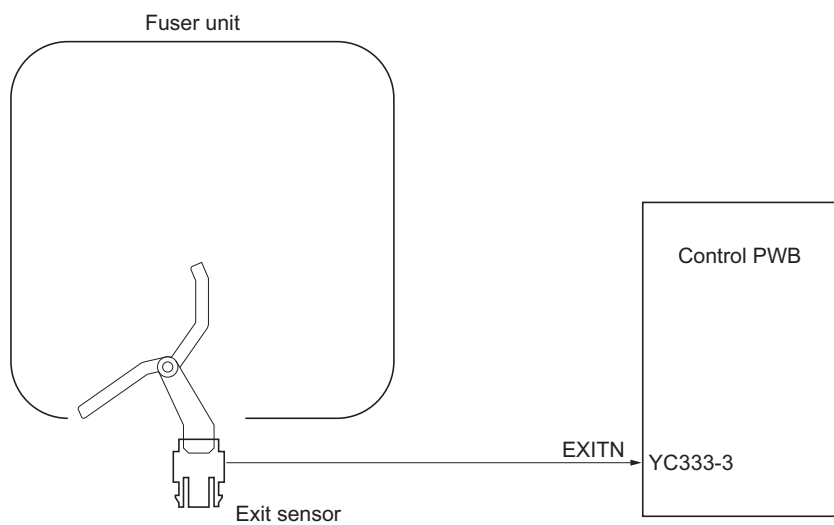

**Figure 2-1-21 Paper exit section block diagram**

### 2-1-9 Duplex/conveying section

The duplex/conveying section consists of conveying path which sends the paper sent from the paper exit section to the paper feed/conveying section when duplex printing.

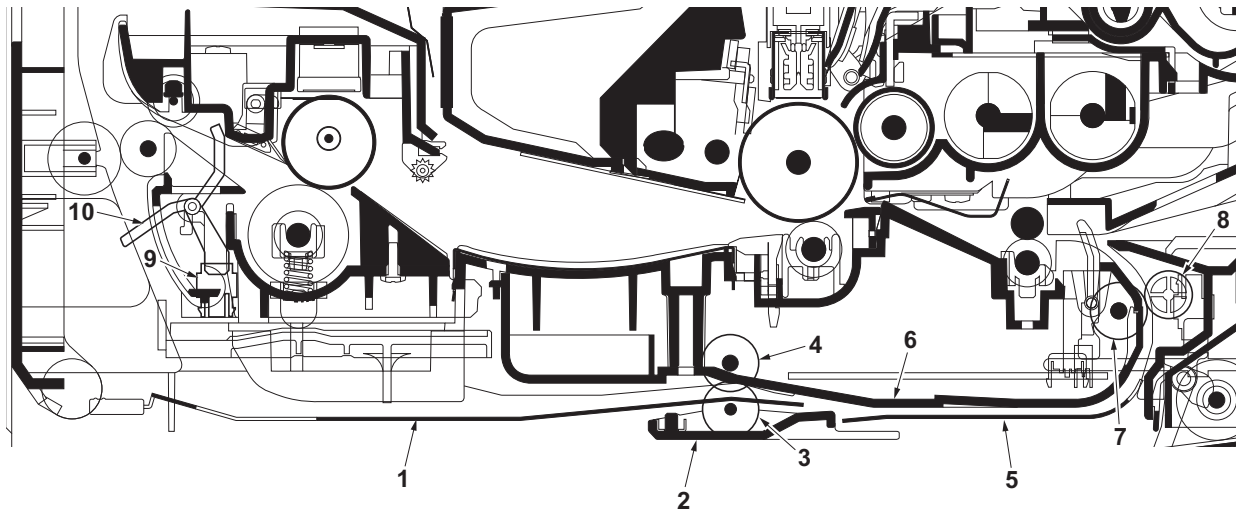

**Figure 2-1-22 Duplex/conveying section**

- (1) DU cover B
- (2) DU holder
- (3) Middle pulley B
- (4) DU roller
- (5) DU cover A
- (6) Lower base cover
- (7) Feed roller
- (8) Feed pulley
- (9) Exit sensor
- (10) Actuator (exit sensor)

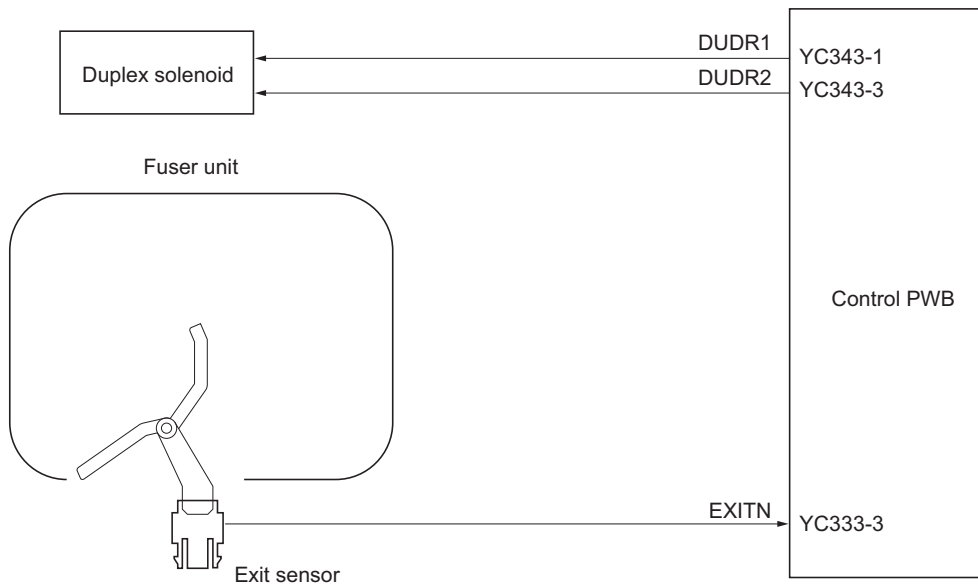
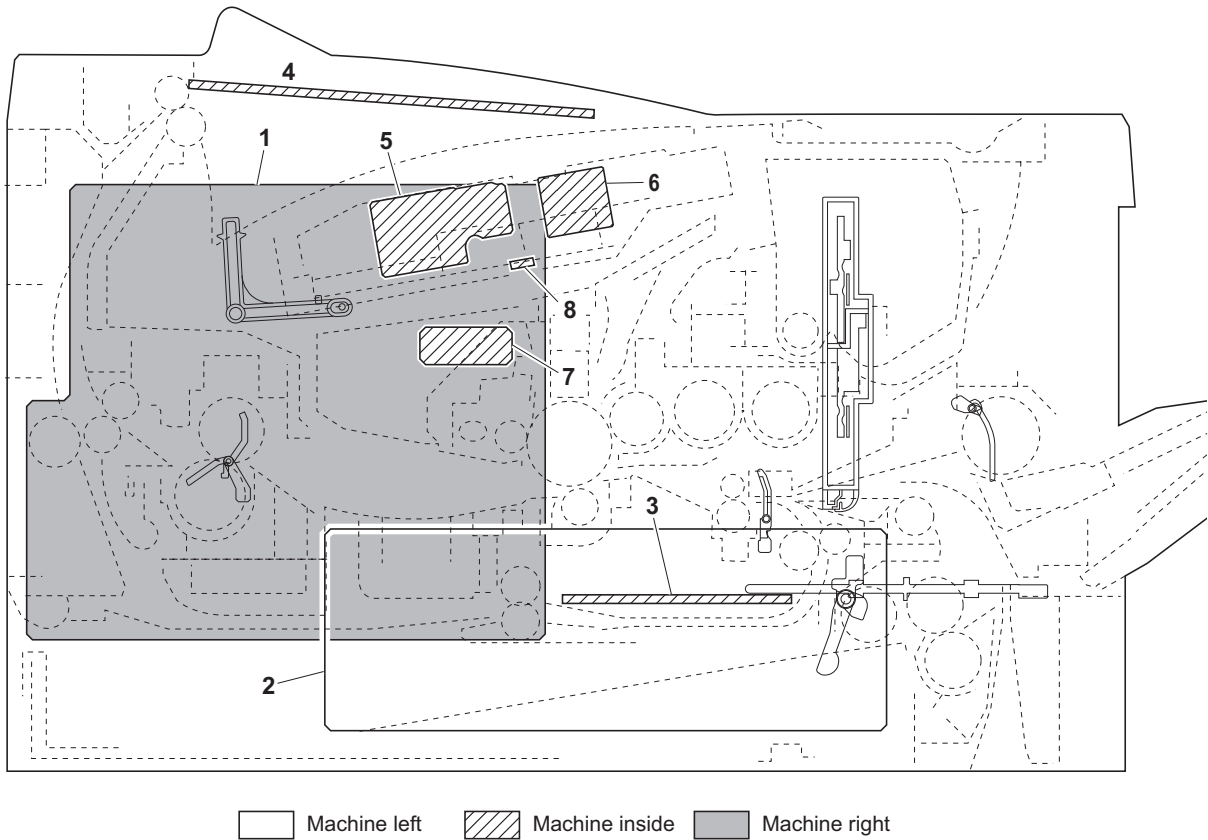

**Figure 2-1-23 Duplex/paper conveying section block diagram**

This page is intentionally left blank.

### 2-2-1 Electrical parts layout

#### (1) PWBs



**Figure 2-2-1 PWBs**

- |                              |  |
|------------------------------|--|
| 1. Control PWB .....         | Main controller: Controls the software such as the print data processing and provides the interface with computers.<br>Engine: Controls printer hardware such as high voltage/bias output control, paper conveying system control, and fuser temperature control, etc. |
| 2. Power source PWB .....    | After full-wave rectification of AC power source input, switching for converting to 24 V DC for output. Controls the fuser heater lamp.  |
| 3. High voltage PWB .....    | Generates main charging, developing bias, transfer bias and separation charger bias.   |
| 4. Operation panel PWB ..... | Consists the LCD, LED indicators and key switches.   |
| 5. APC PWB .....             | Generates and controls the laser beam.   |
| 6. PD PWB .....              | Controls horizontal synchronizing timing of laser beam.  |
| 7. Zener PWB .....           | Adjusts the drum surface potential.  |
| 8. Eraser lamp PWB .....     | Eliminates the residual electrostatic charge on the drum.  |

**List of correspondences of PWB names**

<b>No.</b>	<b>Name used in service manual</b>	<b>Name used in parts list</b>
1	Control PWB	PARTS PWB CONTROL SP
2	Power source PWB	SWITCHING REGULATOR 120V SWITCHING REGULATOR 230V
3	High voltage PWB	PARTS HIGH VOLTAGE UNIT SP
4	Operation panel PWB	PARTS PWB LCD SP
5	APC PWB	-
6	PD PWB	-
7	Zener PWB	-
8	Eraser lamp PWB	-

(2) Switches and sensors

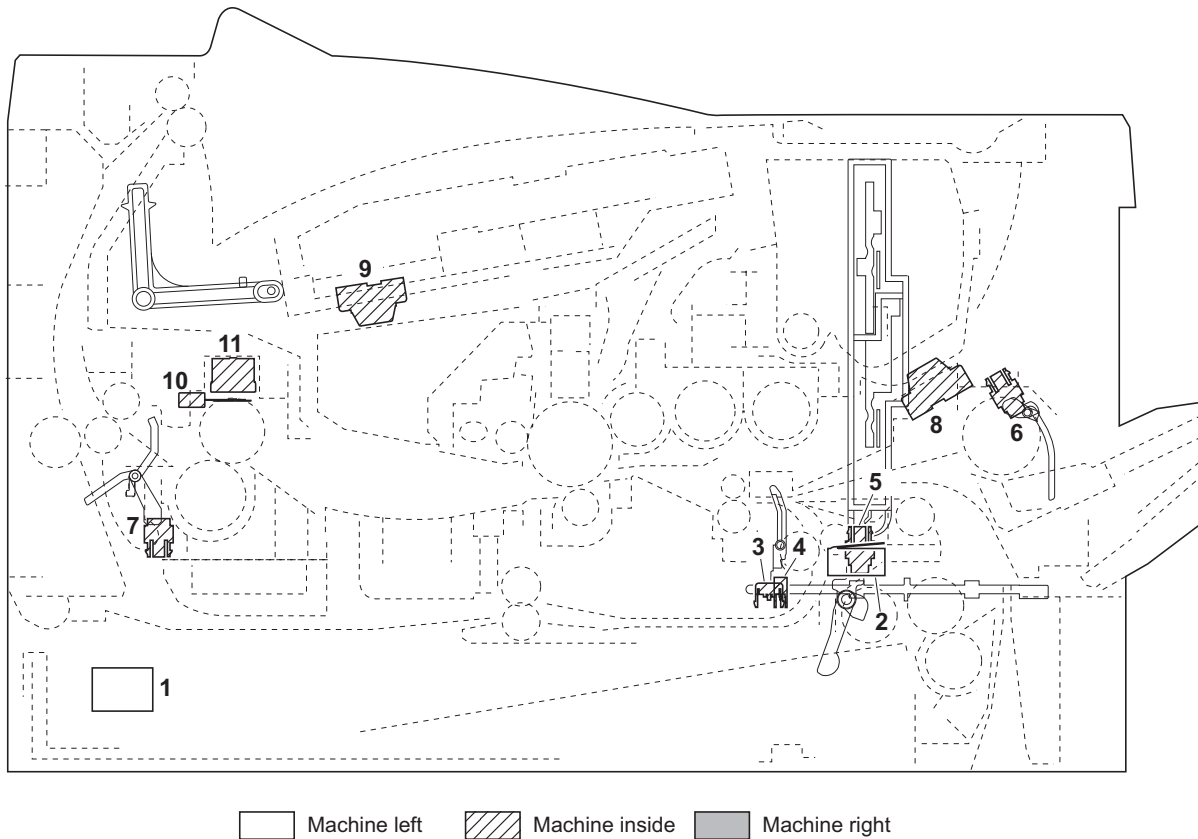

**Figure 2-2-2 Switches and sensors**

- |   |  |
|---|--|
| <ol style="list-style-type: none"> <li>1. Power switch.....</li> <li>2. Interlock switch .....</li> <li>3. Cassette switch.....</li> <li>4. Registration sensor.....</li> <li>5. Paper sensor.....</li> <li>6. MP paper sensor.....</li> <li>7. Exit sensor .....</li> <li>8. Toner sensor .....</li> <li>9. Waste toner sensor.....</li> <li>10. Fuser thermistor.....</li> <li>11. Fuser thermal cutout.....</li> </ol> | <p>Turns ON/OFF the AC power source.</p> <p>Shuts off 24 V DC power line when the top cover is opened.</p> <p>Detects open/close cassette.</p> <p>Detects the timing of primary paper feed.</p> <p>Detects the presence of paper in the cassette.</p> <p>Detects the presence of paper on the MP tray.</p> <p>Detects paper jam in the fuser or duplex conveying section.</p> <p>Detects the quantity of toner in a toner container.</p> <p>Detects when the waste toner reservoir (Drum unit) is full.</p> <p>Measures the heat roller temperature.</p> <p>Shuts off the power source to the fuser heater lamp when the heat roller reaches extremely high temperature.</p> |
|---|--|

**(3) Other electrical components**

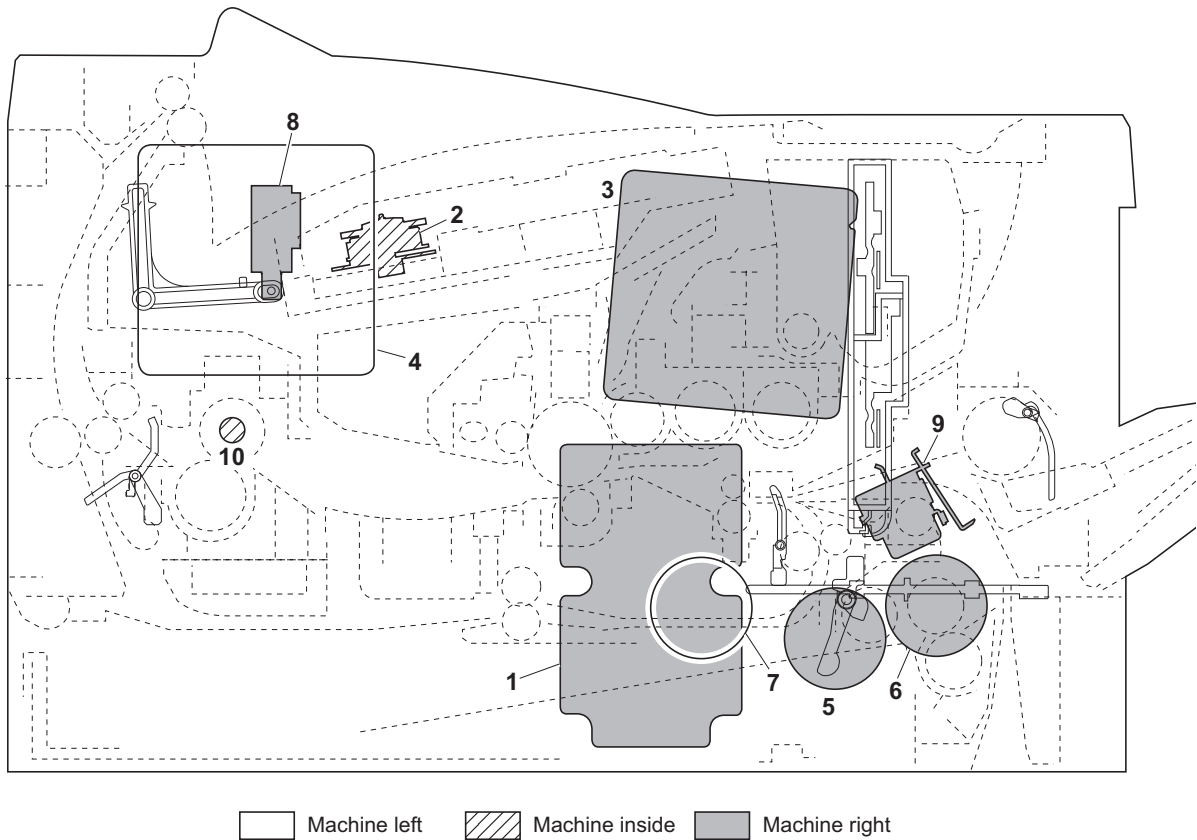

**Figure 2-2-3 Other electrical components**

- 1. Main motor ..... Drives the paper feed/conveying section and fuser unit.
- 2. Polygon motor ..... Drives the polygon mirror.
- 3. Right cooling fan motor ..... Cools the interior of machine.
- 4. Left cooling fan motor ..... Cools the interior of machine.
- 5. Registration clutch ..... Controls the secondary paper feed.
- 6. Paper feed clutch ..... Controls the paper cassette paper feed.
- 7. Developing clutch ..... Controls the toner feed.
- 8. Duplex solenoid ..... Controls the paper conveying at the duplex conveying section.
- 9. MP paper feed solenoid ..... Controls the MPF bottom plate of the MP tray.
- 10. Fuser heater lamp ..... Heats the heat roller.



2-3-1 Power source PWB

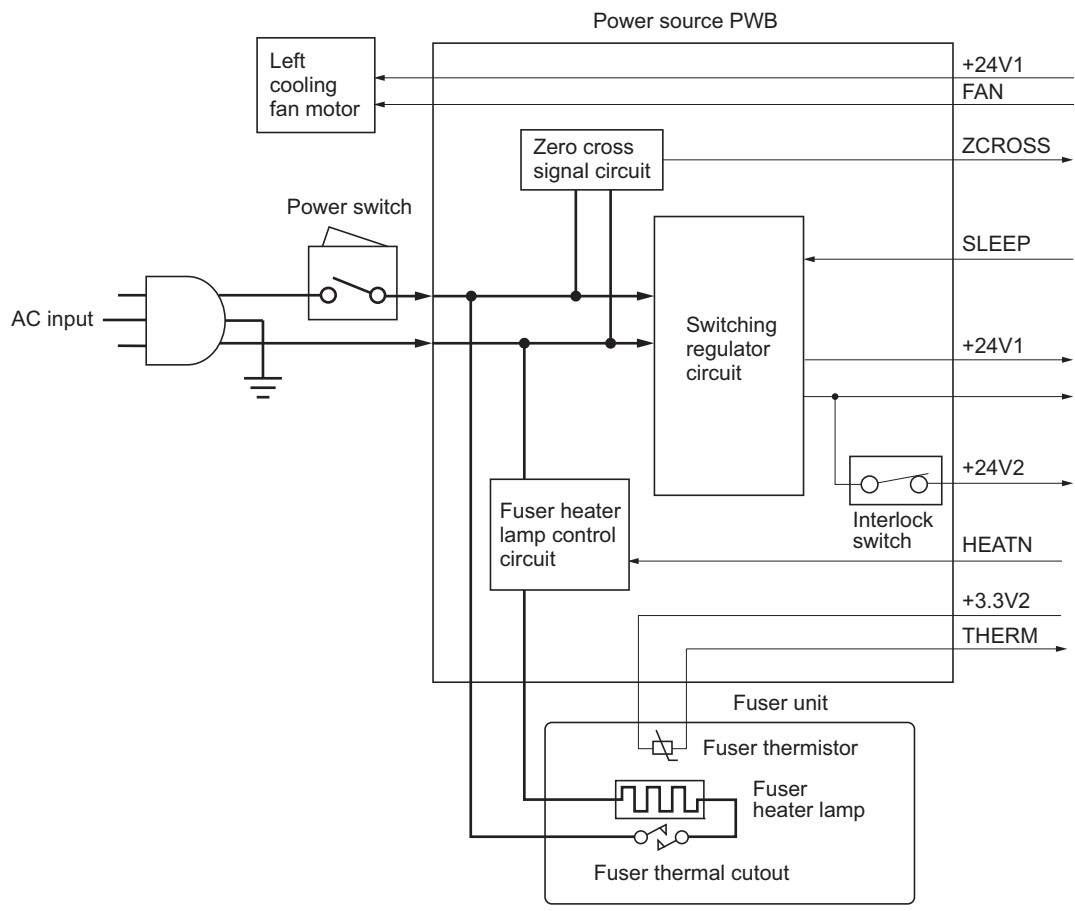

Figure 2-3-1 Power source PWB block diagram

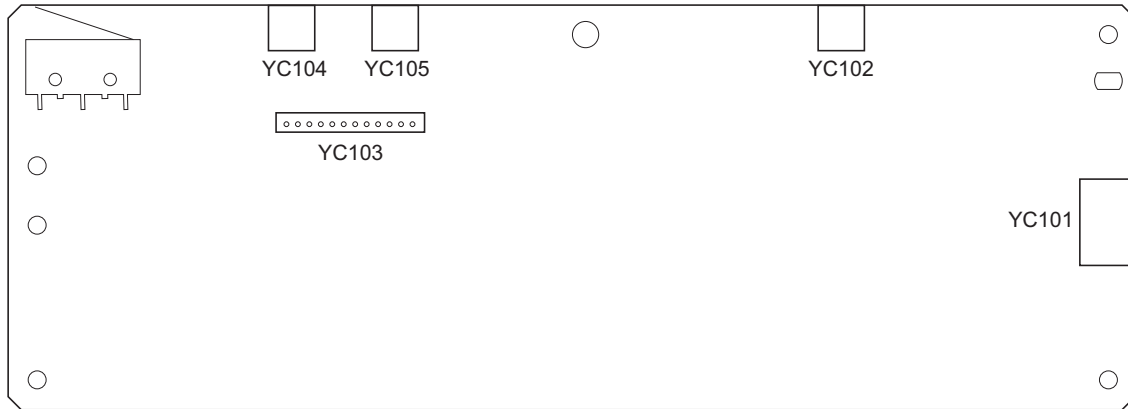

Figure 2-3-2 Power source PWB silk-screen diagram

Connector	Pin	Signal	I/O	Voltage	Description
YC101	1	LIVE	I	120 V AC 220 - 240 V AC	AC power input
Connected to the AC inlet	2	NEUTRAL	I	120 V AC 220 - 240 V AC	AC power input
YC102	1	HEATER COM	O	120 V AC 220 - 240 V AC	Fuser heater lamp output
Connected to the fuser heater lamp	2	N.C.	-	-	Not used
	3	HEATER LIVE	O	120 V AC 220 - 240 V AC	Fuser heater lamp output
YC103	1	+24V1	O	24 V DC	24 V DC power source
Connected to the high voltage PWB	2	SGND	-	-	Ground
	3	FAN	I	0/24 V DC	Left cooling fan motor: On/Off
	4	THERM	O	Analog	Fuser thermistor detection voltage
	5	+3.3V2	I	3.3 V DC	3.3 V DC power source
	6	HEATN	I	0/3.3 V DC	Fuser heater lamp: On/Off
	7	SLEEP	I	0/3.3 V DC	Sleep mode signal: On/Off
	8	ZCROSS	O	0/3.3 V DC (pulse)	Zero cross signal
	9	+24V2	O	24 V DC	24 V DC power source (via interlock switch)
	10	+24V2	O	24 V DC	24 V DC power source (via interlock switch)
	11	PGND	-	-	Ground
	12	PGND	-	-	Ground
YC104	1	+24V1	O	24 V DC	24 V DC power source
Connected to the left cooling fan motor	2	FAN	O	0/24 V DC	Left cooling fan motor: On/Off
YC105	1	+3.3V2	O	3.3 V DC	3.3 V DC power source
Connected to the fuser thermistor	2	THERM	I	Analog	Fuser thermistor detection voltage

2-3-2 Control PWB

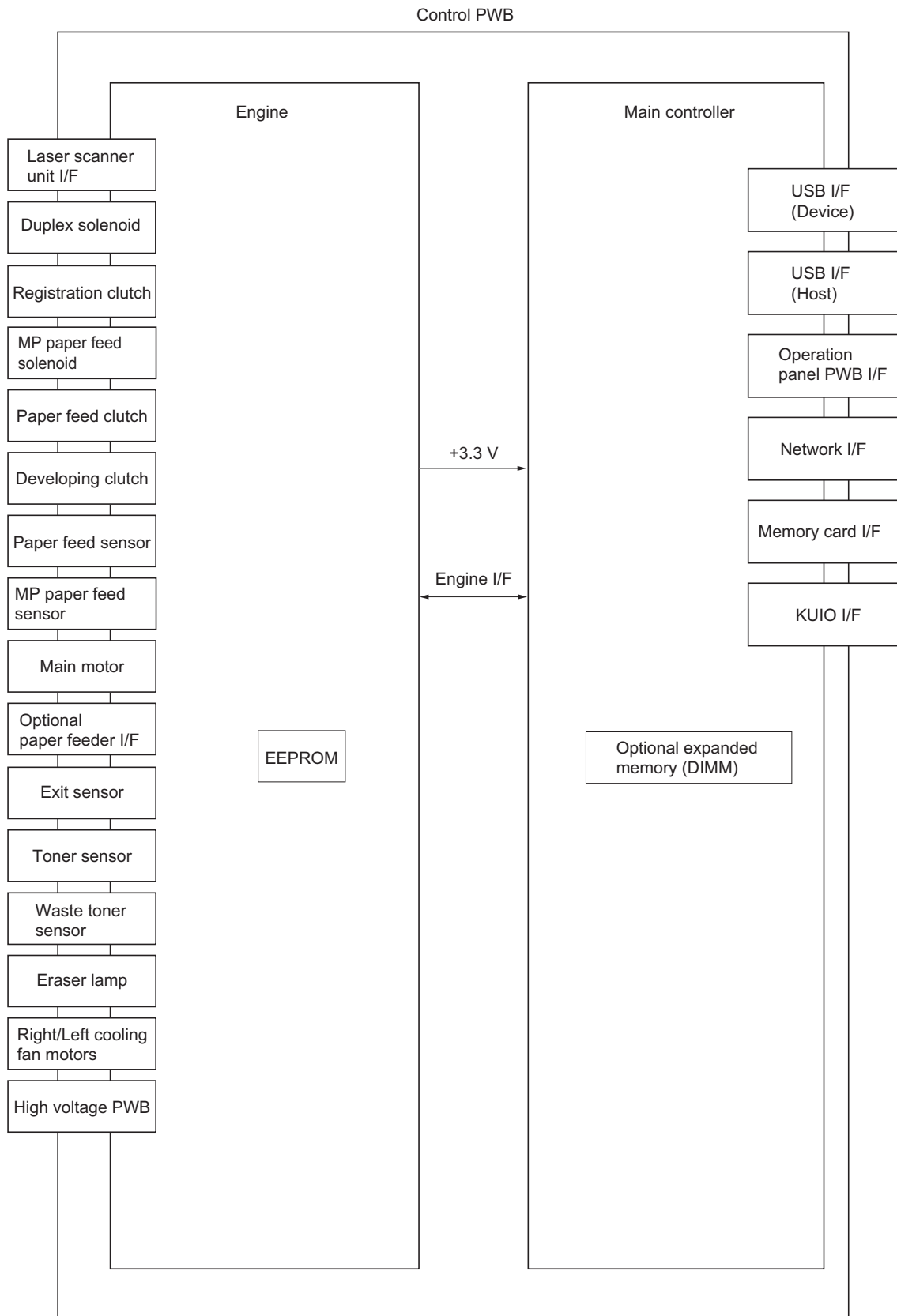

Figure 2-3-3 Control PWB block diagram

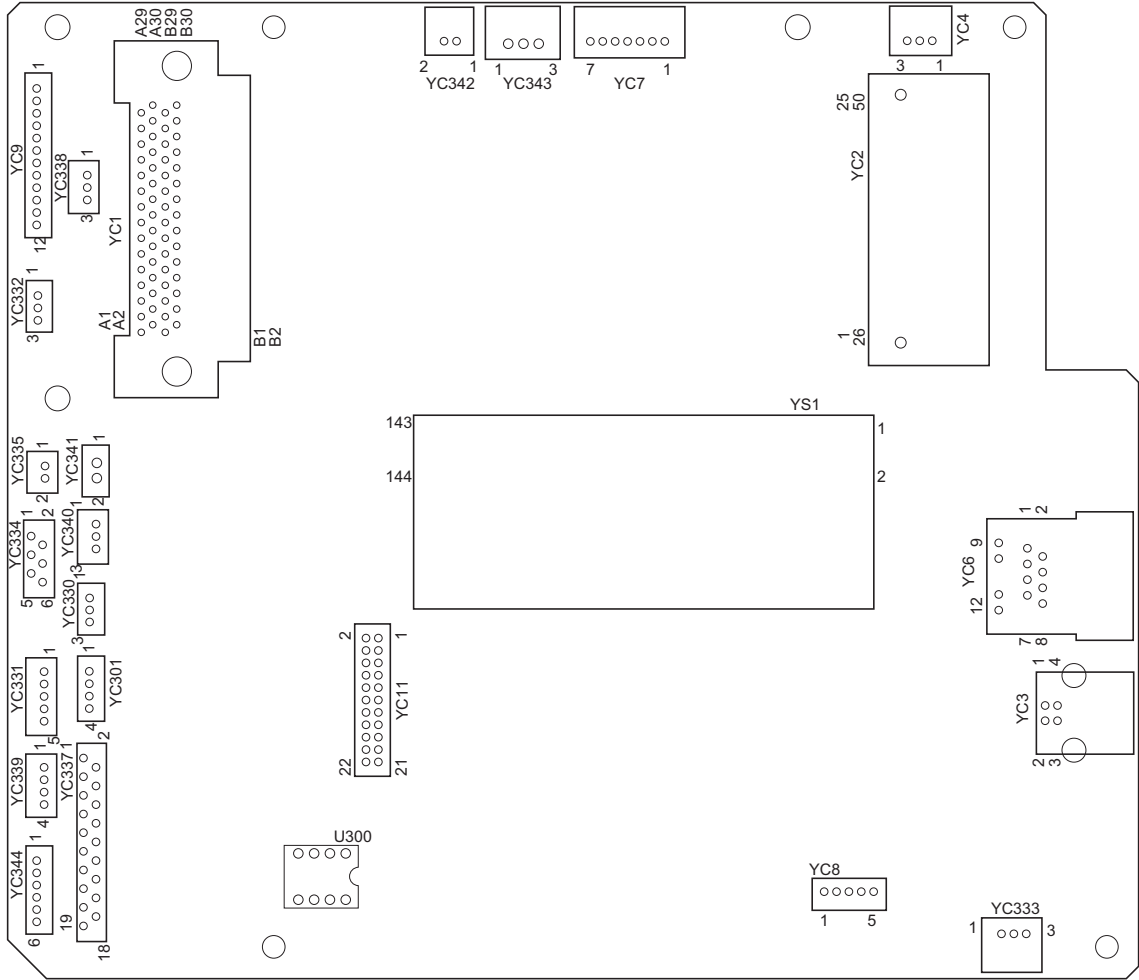

Figure 2-3-4 Control PWB silk-screen diagram

Connector	Pin	Signal	I/O	Voltage	Description
YC4 Connected to the operation panel PWB	1	VBUS	O	5 V DC	5 V DC power source
	2	HUSBDN	I/O	(Differential signal)	Data signal
	3	HUSBDP	I/O	(Differential signal)	Data signal
YC7 Connected to the operation panel PWB	1	+5V	O	5 V DC	5 V DC power source
	2	+3.3V1	O	3.3 V DC	3.3 V DC power source
	3	FPTXD	O	0/3.3 V DC (pulse)	Operation panel PWB transmitting data
	4	FPCTS	I	3.3/0 V DC (pulse)	Transmitting enable signal
	5	FPRXD	I	0/3.3 V DC (pulse)	Operation panel PWB receiving data
	6	SGND	-	-	Ground
	7	FPRSTN	O	3.3/0 V DC	Operation panel PWB reset signal
YC9 Connected to the laser scanner unit	1	+24V3	O	24 V DC	24 V DC power source
	2	PGND	-	-	Ground
	3	PLGDRN	O	0/3.3 V DC	Polygon motor: On/Off
	4	PLGRDYN	I	0/3.3 V DC	Polygon motor ready signal
	5	PLGCLK	O	0/3.3 V DC (pulse)	Polygon motor clock signal
	6	PDN	I	0/3.3 V DC (pulse)	Horizontal synchronizing signal
	7	SGND	-	-	Ground
	8	VDON	O	0/3.3 V DC (pulse)	Video data signal (+)
	9	VDOP	O	0/3.3 V DC (pulse)	Video data signal (-)
	10	OUTPEN	O	0/3.3 V DC	Laser output enable signal
	11	SAMPLEN	O	0/3.3 V DC	Sample/hold timing switching signal
	12	+3.3V2	O	3.3 V DC	3.3 V DC power source
YC330 Connected to the MP paper sensor	1	+3.3V2	O	3.3 V DC	3.3 V DC power source
	2	SGND	-	-	Ground
	3	HANDSN	I	0/3.3 V DC	MP paper sensor: On/Off
YC331 Connected to the main motor	1	+24V3	O	24 V DC	24 V DC power source
	2	PGND	-	-	Ground
	3	MMOTRDYN	I	0/3.3 V DC	Main motor ready signal
	4	MMOTCLK	O	0/3.3 V DC (pulse)	Main motor clock signal
	5	REMOTEN	O	0/3.3 V DC	Main motor: On/Off
YC332 Connected to the paper sensor	1	+3.3V2	O	3.3 V DC	3.3 V DC power source
	2	SGND	-	-	Ground
	3	PAPER	I	0/3.3 V DC	Paper sensor: On/Off
YC333 Connected to the exit sensor	1	+3.3V2	O	3.3 V DC	3.3 V DC power source
	2	SGND	-	-	Ground
	3	EXITN	I	0/3.3 V DC	Exit sensor: On/Off

Connector	Pin	Signal	I/O	Voltage	Description
YC334	1	+24V3	O	24 V DC	24 V DC power source
Connected to the registration clutch, paper feed clutch and developing clutch	2	REGDRN	O	0/24 V DC	Registration clutch: On/Off
	3	+24V3	O	24 V DC	24 V DC power source
	4	FEDDRN	O	0/24 V DC	Paper feed clutch: On/Off
	5	+24V3	O	24 V DC	24 V DC power source
	6	DLPDRN	O	0/24 V DC	Developing clutch: On/Off
YC335	1	+24V3	O	24 V DC	24 V DC power source
Connected to the MP paper feed solenoid	2	MPFDRN	O	0/24 V DC	MP paper feed solenoid: On/Off
YC337	1	+24V1	I	24 V DC	24 V DC power source
Connected to the high voltage PWB	2	+3.3V2	O	3.3 V DC	3.3 V DC power source
	3	ZCROSS	I	0/3.3 V DC (pulse)	Zero cross signal
	4	FAN	O	0/24 V DC	Left cooling fan motor: On/Off
	5	HEATN	O	0/3.3 V DC	Fuser heater lamp: On/Off
	6	SLEEP	O	0/3.3 V DC	Sleep mode signal: On/Off
	7	MHVDR	O	0/3.3 V DC	Main charger output signal: On/Off
	8	RTHVDR	O	0/3.3 V DC	Transfer (reverse) bias output signal: On/Off
	9	PSEL1	O	0/3.3 V DC	Transfer (reverse) bias control signal: On/Off
	10	HVCLK	O	0/3.3 V DC (pulse)	Developing bias clock signal
	11	REGN	I	0/3.3 V DC	Registration sensor: On/Off
	12	TCNT	O	PWM	Transfer current control signal
	13	MCNT	O	PWM	Main charger output control signal
	14	THVDR	O	0/3.3 V DC	Transfer bias output signal: On/Off
	15	CASE	I	Analog	Cassette switch: On/Off
	16	THERM	I	Analog	Fuser thermistor detection voltage
	17	+24V3	O	24 V DC	24 V DC power source
	18	SGND	-	-	Ground
	19	SEPA	O	0/3.3 V DC	Separation bias output signal: On/Off
YC338	1	+3.3V2	O	3.3 V DC	3.3 V DC power source
Connected to the waste toner sensor	2	TNFULL	I	0/3.3 V DC	Waste toner full detection signal
	3	SGND	-	-	Ground
YC339	1	+24V2	I	24 V DC	24 V DC power source
Connected to the high voltage PWB	2	+24V2	I	24 V DC	24 V DC power source
	3	PGND	-	-	Ground
	4	PGND	-	-	Ground
YC340	1	+3.3V2	O	3.3 V DC	3.3 V DC power source
Connected to the toner sensor	2	EMPTY	I	0/3.3 V DC	Toner quantity detection signal
	3	SGND	-	-	Ground

Connector	Pin	Signal	I/O	Voltage	Description
YC341	1	+24V1	O	24 V DC	24 V DC power source
Connected to the right cooling fan motor	2	FAN	O	0/24 V DC	Right cooling fan motor: On/Off
YC342	1	ERASER	O	0/24 V DC	Eraser lamp: On/Off
Connected to the eraser lamp	2	ERASRW	O	24 V DC	24 V DC power source
YC343	1	DUDR1	O	0/24 V DC	Duplex solenoid (activate): On/Off
Connected to the duplex solenoid	2	COMMON	O	24 V DC	24 V DC power source
	3	DUDR2	O	0/24 V DC	Duplex solenoid (return): On/Off
YC344	1	+24V3	O	24 V DC	24 V DC power source
Connected to the optional paperfeeder 1	2	PGND	-	-	Ground
	3	PFSI	I	0/3.3 V DC (pulse)	Serial communication data input signal
	4	PFSO	O	0/3.3 V DC (pulse)	Serial communication data output signal
	5	PFSEL	O	0/3.3 V DC	Paper feeder selection signal
	6	+3.3V1	O	3.3 V DC	3.3 V DC power source

This page is intentionally left blank.



# 2-4-1 Appendixes

## (1) Wiring diagram

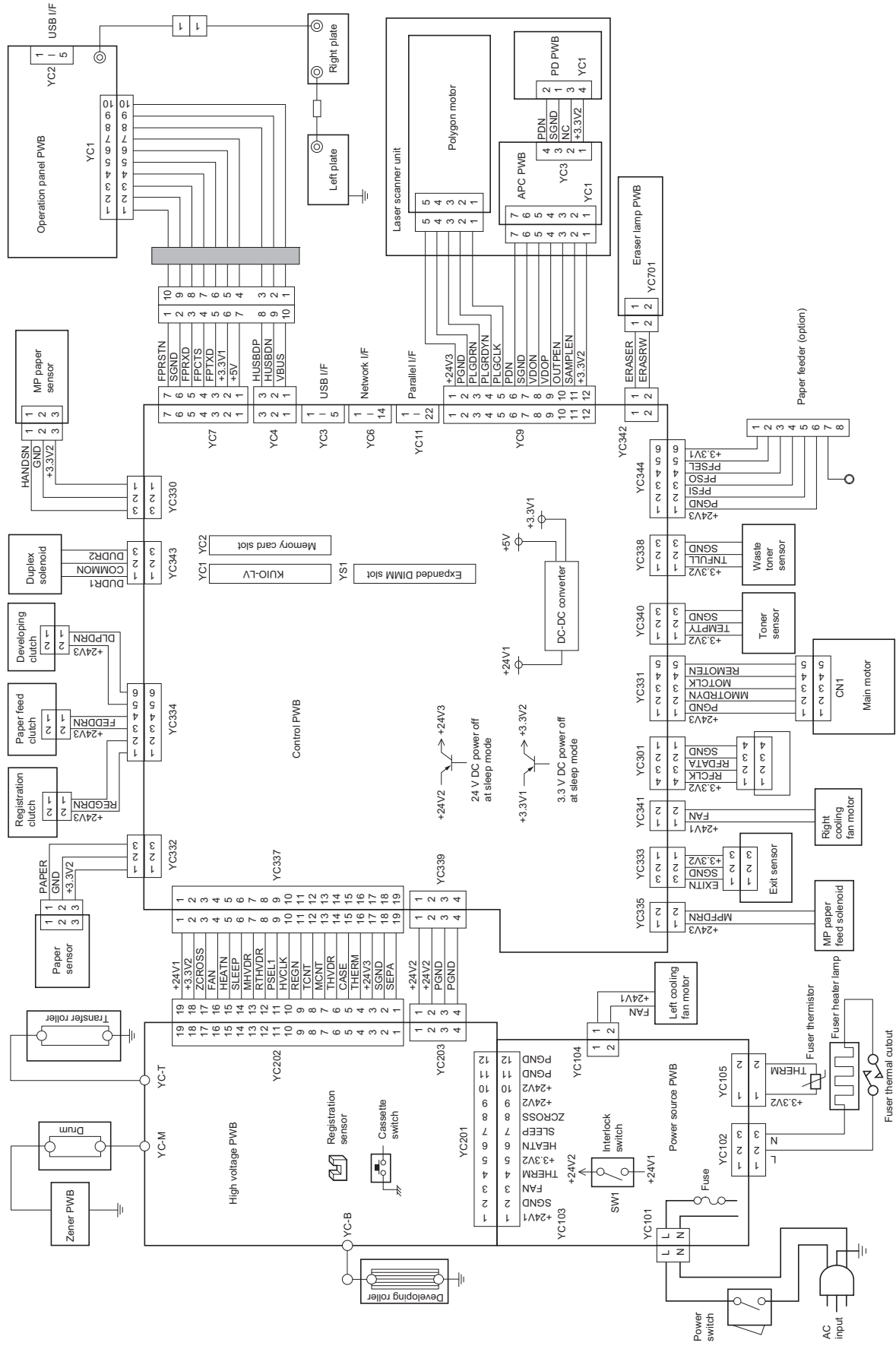

**(2) Repetitive defects gauge**

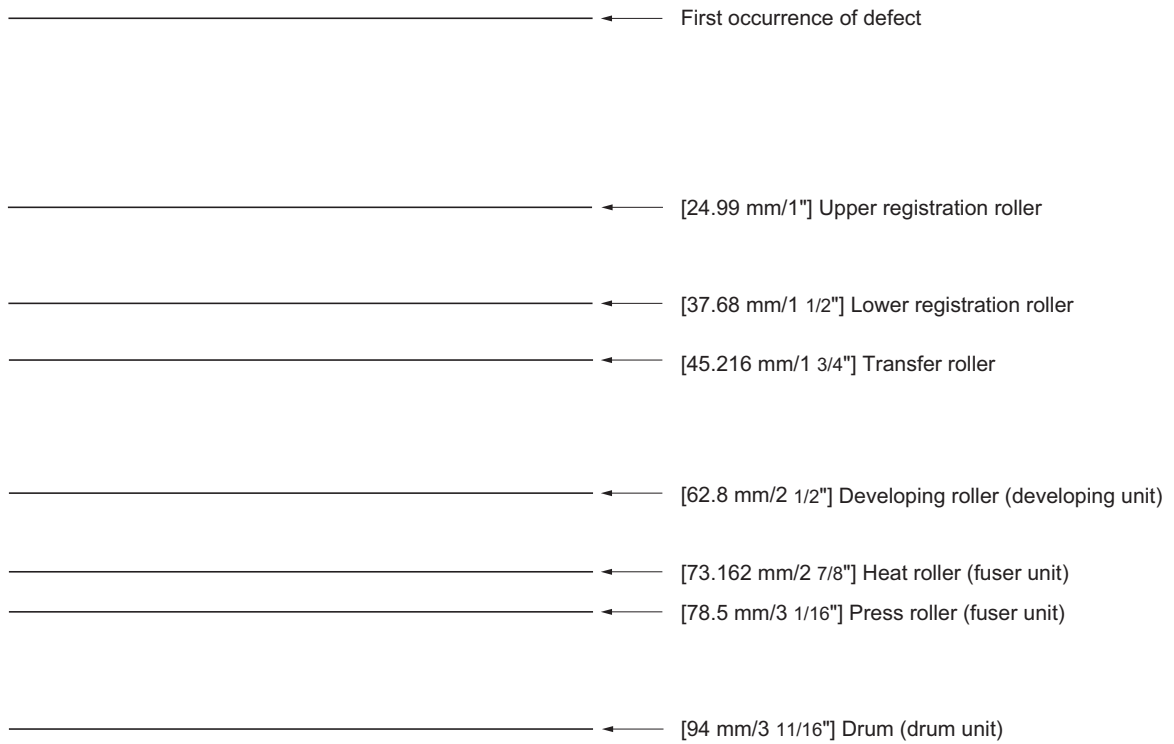

**(3) Maintenance parts list**

<b>Maintenance part name</b>		<b>Part No.</b>	<b>Alternative part No.</b>
<b>Name used in service manual</b>	<b>Name used in parts list</b>		
Maintenance kit (120 V specifications)	MK-172/MAINTENANCE KIT DK-170 DV-172(U)	1702LZ7US0	072LZ7US
Maintenance kit (230 V specifications)	MK-170/MAINTENANCE KIT DK-170 DV-170(E)	1702LZ8NL0	072LZ8NL
Maintenance kit (240 V specifications)	MK-174/MAINTENANCE KIT DK-170 DV-174(AO)	1702LZ8AS0	072LZ8AS

This page is intentionally left blank.

## **KYOCERA MITA EUROPE B.V.**

Bloemlaan 4, 2132 NP Hoofddorp,  
The Netherlands  
Phone: +31.20.654.0000  
Home page: <http://www.kyoceramita-europe.com>  
Email: [info@kyoceramita-europe.com](mailto:info@kyoceramita-europe.com)

**KYOCERA MITA NEDERLAND B.V.**  
Beechavenue 25, 1119RA Schiphol-Rijk  
The Netherlands  
Phone: +31.20.58.77.200

**KYOCERA MITA (UK) LTD**  
8 Beacontree Plaza  
Gillette Way Reading Berks RG2 OBS,  
U.K.  
Phone: +44.1189.311.500

**KYOCERA MITA ITALIA S.p.A.**  
Via G. Verdi, 89 / 91, 20063 Cernusco s/N  
Milano, Italy  
Phone: +39.02.92179.1

**S.A. KYOCERA MITA BELGIUM N.V.**  
Sint-Martinusweg 199-201, 1930 Zaventem,  
Belgium  
Phone: +32.2.720.9270

**KYOCERA MITA FRANCE S.A.**  
Parc Les Algorithmes Saint Aubin  
91194 GIF-SUR-YVETTE,  
France  
Phone: +33.1.6985.2600

**KYOCERA MITA ESPAÑA S.A.**  
Edificio Kyocera, Avda de Manacor No. 2,  
28290 Las Matas (Madrid),  
Spain  
Phone: +34.91.631.8392

**KYOCERA MITA FINLAND OY**  
Atomitie 5C, 00370 Helsinki,  
Finland  
Phone: +358.9.4780.5200

**KYOCERA MITA (SCHWEIZ)**  
Hohlstrasse 614, 8048 Zürich  
Switzerland  
Phone: +41.44.908.4949

**KYOCERA MITA DEUTSCHLAND GMBH**  
Otto-Hahn-Str. 12 D-40670 Meerbusch,  
Germany  
Phone: +49.2159.918.0

**KYOCERA MITA GMBH AUSTRIA**  
Eduard-Kittenberger-Gasse 95,  
1230 Wien,  
Austria  
Phone: +43.1.86338

**KYOCERA MITA SVENSKA AB**  
Esbogatan 16B 164 75 Kista,  
Sweden  
Phone: +46.8.546.55000

**KYOCERA MITA NORGE**  
Postboks 150 Oppsal, NO 0619 Oslo  
Olaf Helsetsvetvei 6, NO 0694 Oslo,  
Norway  
Phone: +47.22.62.73.00

**KYOCERA MITA DANMARK A/S**  
Ejby Industrivej 1, DK-2600 Glostrup,  
Denmark  
Phone: +45.7022.3880

**KYOCERA MITA PORTUGAL LDA.**  
Rua do Centro Cultural, 41 (Alvalade) 1700-106 Lisboa,  
Portugal  
Phone: +351.21.843.6780

**KYOCERA MITA SOUTH AFRICA (PTY) LTD.**  
49 Kyalami Boulevard,  
Kyalami Business Park Midrand,  
South Africa  
Phone: +27.(0)11.540.2600

## **KYOCERA MITA AMERICA, INC.**

**Headquarters:**  
225 Sand Road,  
Fairfield, New Jersey 07004-0008,  
U.S.A.  
Phone: (973) 808-8444

**KYOCERA MITA AUSTRALIA PTY. LTD.**  
Level 3, 6-10 Talavera Road, North Ryde,  
N.S.W. 2113 Australia  
Phone: (02) 9888-9999

**KYOCERA MITA NEW ZEALAND LTD.**  
1-3 Parkhead Place, Albany  
P.O. Box 302 125 NHPC, Auckland,  
New Zealand  
Phone: (09) 415-4517

**KYOCERA MITA (THAILAND) CORP., LTD.**  
9/209 Ratchada-Prachachem Road,  
Bang Sue, Bangkok 10800, Thailand  
Phone: (02) 586-0333

**KYOCERA MITA SINGAPORE PTE LTD.**  
121 Genting Lane, 3rd Level,  
Singapore 349572  
Phone: 67418733

**KYOCERA MITA HONG KONG LIMITED**  
16/F., Mita Centre,  
552-566, Castle Peak Road,  
Tsuen Wan, New Territories,  
Hong Kong  
Phone: 24297422

**KYOCERA MITA TAIWAN Corporation.**  
6F., No.37, Sec. 3, Minquan E. Rd.,  
Zhongshan Dist., Taipei 104, Taiwan R.O.C.  
Phone: (02) 25076709

## **KYOCERA MITA Corporation**

2-28, 1-chome, Tamatsukuri, Chuo-ku  
Osaka 540-8585, Japan  
Phone: (06) 6764-3555  
<http://www.kyoceramita.com>

## KYOCERA MITA AMERICA, INC.

### **Headquarters:**

225 Sand Road,  
Fairfield, New Jersey 07004-0008  
TEL : (973) 808-8444  
FAX : (973) 882-6000

### **New York Branch:**

1410 Broadway 23rd floor  
New York, NY 10018  
TEL : (917) 286-5400  
FAX : (917) 286-5402

### **Northeastern Region:**

225 Sand Road,  
Fairfield, New Jersey 07004-0008  
TEL : (973) 808-8444  
FAX : (973) 882-4401

### **Midwestern Region:**

201 Hansen Court Suite 119  
Wood Dale, Illinois 60191  
TEL : (630) 238-9982  
FAX : (630) 238-9487

### **Western Region:**

14101 Alton Parkway,  
Irvine, California 92618-7006  
TEL : (949) 457-9000  
FAX : (949) 457-9119

### **Southeastern Region:**

1500 Oakbrook Drive,  
Norcross, Georgia 30093  
TEL : (770) 729-9786  
FAX : (770) 729-9873

### **Southwestern Region:**

2825 West Story Road,  
Irving, Texas 75038-5299  
TEL : (972) 550-8987  
FAX : (972) 252-9786

### **National Operation Center & National Training Center:**

2825 West Story Road,  
Irving, Texas 75038-5299  
TEL : (972) 659-0055  
FAX : (972) 570-5816

### **Latin America Division:**

8240 N.W. 52nd. Terrace Dawson Building,  
Suite 108 Miami, Florida 33166  
TEL : (305) 421-6640  
FAX : (305) 421-6666

## KYOCERA MITA CANADA, LTD.

6120 Kestrel Road, Mississauga,  
Ontario L5T 1S8, Canada  
TEL : (905) 670-4425  
FAX : (905) 670-8116

## KYOCERA MITA MEXICO, S.A. DE C.V.

Av. 16 de Septiembre #407  
Col. Santa Inés,  
Azcapotzalco México,  
D.F. 02130, México  
TEL : (55) 5383-2741  
FAX : (55) 5383-7804

©2010 KYOCERA MITA Corporation

<http://www.kyoceramita.com>

 **KYOCERA** is a trademark of Kyocera Corporation

Printed in U.S.A.



---

# PF-100

# SERVICE MANUAL

Published in March 2008  
Rev.1

## **CAUTION**

RISK OF EXPLOSION IF BATTERY IS REPLACED BY AN INCORRECT TYPE. DISPOSE OF USED BATTERIES ACCORDING TO THE INSTRUCTIONS.

It may be illegal to dispose of this battery into the municipal waste stream. Check with your local solid waste officials for details in your area for proper disposal.

## **ATTENTION**

IL Y A UN RISQUE D'EXPLOSION SI LA BATTERIE EST REMPLACÉE PAR UN MODÈLE DE TYPE INCORRECT. METTRE AU REBUT LES BATTERIES UTILISÉES SELON LES INSTRUCTIONS DONNÉES.

Il peut être illégal de jeter les batteries dans des eaux d'égout municipales. Vérifiez avec les fonctionnaires municipaux de votre région pour les détails concernant des déchets solides et une mise au rebut appropriée.



**Revision history**

<b>Revision</b>	<b>Date</b>	<b>Replaced pages</b>	<b>Remarks</b>
1	13 March 2008	1-2-1, 1-2-2	

This page is intentionally left blank.

---

# Safety precautions

---

This booklet provides safety warnings and precautions for our service personnel to ensure the safety of their customers, their machines as well as themselves during maintenance activities. Service personnel are advised to read this booklet carefully to familiarize themselves with the warnings and precautions described here before engaging in maintenance activities.

## Safety warnings and precautions

Various symbols are used to protect our service personnel and customers from physical danger and to prevent damage to their property. These symbols are described below:

 **DANGER:** High risk of serious bodily injury or death may result from insufficient attention to or incorrect compliance with warning messages using this symbol.

 **WARNING:** Serious bodily injury or death may result from insufficient attention to or incorrect compliance with warning messages using this symbol.

 **CAUTION:** Bodily injury or damage to property may result from insufficient attention to or incorrect compliance with warning messages using this symbol.

### Symbols

The triangle ( $\triangle$ ) symbol indicates a warning including danger and caution. The specific point of attention is shown inside the symbol.



General warning.



Warning of risk of electric shock.



Warning of high temperature.

 indicates a prohibited action. The specific prohibition is shown inside the symbol.



General prohibited action.



Disassembly prohibited.

 indicates that action is required. The specific action required is shown inside the symbol.



General action required.





Remove the power plug from the wall outlet.











Always ground the copier.

# 1. Installation Precautions

## WARNING











- Do not use a power supply with a voltage other than that specified. Avoid multiple connections to one outlet: they may cause fire or electric shock. When using an extension cable, always check that it is adequate for the rated current. .... 
- Connect the ground wire to a suitable grounding point. Not grounding the copier may cause fire or electric shock. Connecting the earth wire to an object not approved for the purpose may cause explosion or electric shock. Never connect the ground cable to any of the following: gas pipes, lightning rods, ground cables for telephone lines and water pipes or faucets not approved by the proper authorities. .... 

## CAUTION:





- Do not place the copier on an infirm or angled surface: the copier may tip over, causing injury. .... 
- Do not install the copier in a humid or dusty place. This may cause fire or electric shock. .... 
- Do not install the copier near a radiator, heater, other heat source or near flammable material.  
  
This may cause fire. .... 
- Allow sufficient space around the copier to allow the ventilation grills to keep the machine as cool as possible. Insufficient ventilation may cause heat buildup and poor copying performance. .... 
- Always handle the machine by the correct locations when moving it. .... 
- Always use anti-toppling and locking devices on copiers so equipped. Failure to do this may cause the copier to move unexpectedly or topple, leading to injury. .... 
- Avoid inhaling toner or developer excessively. Protect the eyes. If toner or developer is accidentally ingested, drink a lot of water to dilute it in the stomach and obtain medical attention immediately. If it gets into the eyes, rinse immediately with copious amounts of water and obtain medical attention. .... 
- Advise customers that they must always follow the safety warnings and precautions in the copier's instruction handbook. .... 

## 2. Precautions for Maintenance

### WARNING

- Always remove the power plug from the wall outlet before starting machine disassembly. .... 
- Always follow the procedures for maintenance described in the service manual and other related brochures. .... 
- Under no circumstances attempt to bypass or disable safety features including safety mechanisms and protective circuits. .... 
- Always use parts having the correct specifications. .... 
- Always use the thermostat or thermal fuse specified in the service manual or other related brochure when replacing them. Using a piece of wire, for example, could lead to fire or other serious accident. .... 
- When the service manual or other serious brochure specifies a distance or gap for installation of a part, always use the correct scale and measure carefully. .... 
- Always check that the copier is correctly connected to an outlet with a ground connection. .... 
- Check that the power cable covering is free of damage. Check that the power plug is dust-free. If it is dirty, clean it to remove the risk of fire or electric shock. .... 
- Never attempt to disassemble the optical unit in machines using lasers. Leaking laser light may damage eyesight. .... 
- Handle the charger sections with care. They are charged to high potentials and may cause electric shock if handled improperly. .... 

### CAUTION

- Wear safe clothing. If wearing loose clothing or accessories such as ties, make sure they are safely secured so they will not be caught in rotating sections. .... 
- Use utmost caution when working on a powered machine. Keep away from chains and belts. .... 
- Handle the fixing section with care to avoid burns as it can be extremely hot. .... 
- Check that the fixing unit thermistor, heat and press rollers are clean. Dirt on them can cause abnormally high temperatures. .... 

• Do not remove the ozone filter, if any, from the copier except for routine replacement. ....



• Do not pull on the AC power cord or connector wires on high-voltage components when removing them; always hold the plug itself. ....



• Do not route the power cable where it may be stood on or trapped. If necessary, protect it with a cable cover or other appropriate item. ....



• Treat the ends of the wire carefully when installing a new charger wire to avoid electric leaks. ....



• Remove toner completely from electronic components. ....



• Run wire harnesses carefully so that wires will not be trapped or damaged. ....



• After maintenance, always check that all the parts, screws, connectors and wires that were removed, have been refitted correctly. Special attention should be paid to any forgotten connector, trapped wire and missing screws. ....



• Check that all the caution labels that should be present on the machine according to the instruction handbook are clean and not peeling. Replace with new ones if necessary. ....



• Handle greases and solvents with care by following the instructions below: .....



Use only a small amount of solvent at a time, being careful not to spill. Wipe spills off completely. Ventilate the room well while using grease or solvents.

Allow applied solvents to evaporate completely before refitting the covers or turning the power switch on. Always wash hands afterwards.

• Never dispose of toner or toner bottles in fire. Toner may cause sparks when exposed directly to fire in a furnace, etc. ....



• Should smoke be seen coming from the copier, remove the power plug from the wall outlet immediately. ....



### 3.Miscellaneous

#### WARNING

• Never attempt to heat the drum or expose it to any organic solvents such as alcohol, other than the specified refiner; it may generate toxic gas. ....



This page is intentionally left blank.



# CONTENTS

<b>1-1 Specifications</b>	
1-1-1 Specifications .....	1-1-1
1-1-2 Parts names .....	1-1-2
1-1-3 Machine cross section .....	1-1-3
<b>1-2 Installation</b>	
1-2-1 Installation environment .....	1-2-1
1-2-2 Unpacking .....	1-2-2
(1) Unpacking .....	1-2-2
(2) Removing the cassette spacer .....	1-2-3
<b>1-3 Troubleshooting</b>	
1-3-1 Paper misfeed detection .....	1-3-1
(1) Paper misfeed indication .....	1-3-1
(2) Paper misfeed detection .....	1-3-2
1-3-2 Self-diagnostic function .....	1-3-3
(1) Self-diagnostic function .....	1-3-3
(2) Self diagnostic codes indication .....	1-3-3
(3) Self diagnostic codes .....	1-3-5
1-3-3 Electric problems .....	1-3-6
1-3-4 Mechanical problems .....	1-3-7
<b>1-4 Assembly and Disassembly</b>	
1-4-1 Precautions for assembly and disassembly .....	1-4-1
(1) Precautions .....	1-4-1
1-4-2 Paper feed section .....	1-4-2
(1) Detaching and refitting the middle roller/feed bracket assembly (paper feed roller and pickup roller) .....	1-4-2
(2) Detaching and refitting the retard roller assembly (retard roller) .....	1-4-4
1-4-3 PWB .....	1-4-6
(1) Detaching and refitting the PF main PWB .....	1-4-6
<b>2-1 Mechanical Construction</b>	
2-1-1 Paper feed section .....	2-1-1
(1) Paper feed section .....	2-1-1
<b>2-2 Electrical Parts Layout</b>	
2-2-1 Electrical parts layout .....	2-2-1
(1) Electrical parts layout .....	2-2-1
<b>2-3 Operation of the PWBs</b>	
2-3-1 PF main PWB .....	2-3-1
<b>2-4 Appendixes</b>	
2-4-1 Appendixes .....	2-4-1
(1) Wiring diagram .....	2-4-1

This page is intentionally left blank.

**1-1-1 Specifications**

Paper size .....	A4, A5, B5, Letter, Legal, Folio, Oficio II
Paper capacity .....	250 sheets (80 g/m <sup>2</sup> )
Dimensions .....	375 mm (W) × 390 mm (D) × 100 mm (H) 14 3/4" (W) × 15 3/8" (D) × 3 15/16" (H)
Weight.....	3.5 kg or less/7.7 lbs or less
Power source.....	Electrically connected to the printer (24 V DC, 3.3 V DC)

Note: These specifications are subject to change without notice.

1-1-2 Parts names

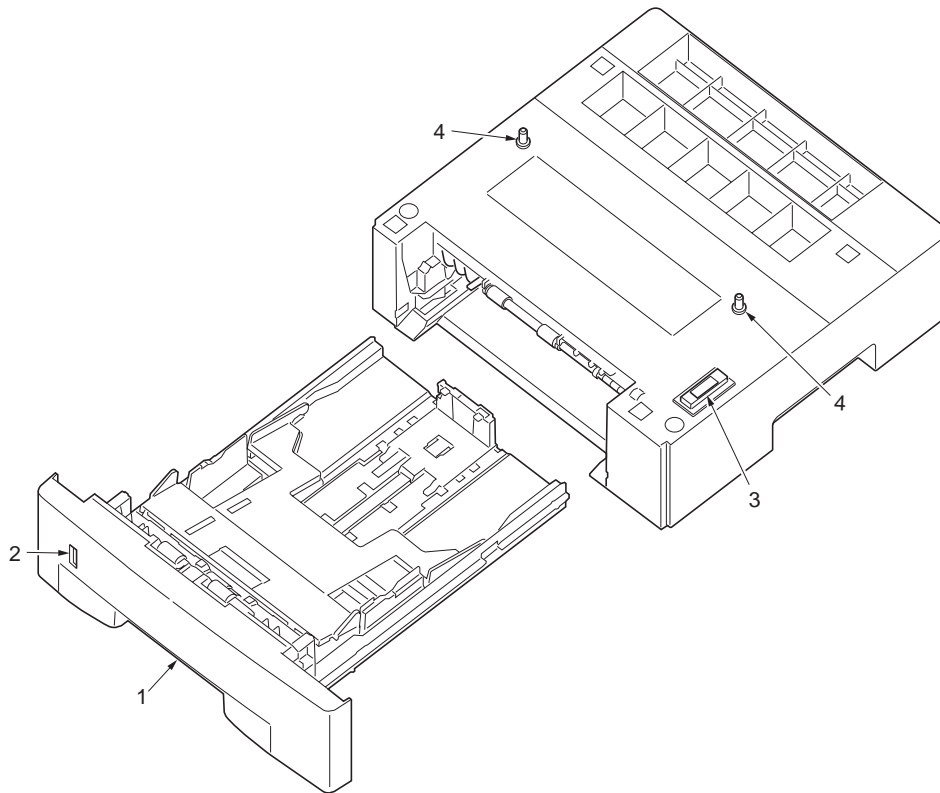

Figure 1-1-1

- 1. Cassette
- 2. Paper gauge
- 3. Interface connector
- 4. Positioning pins

1-1-3 Machine cross section

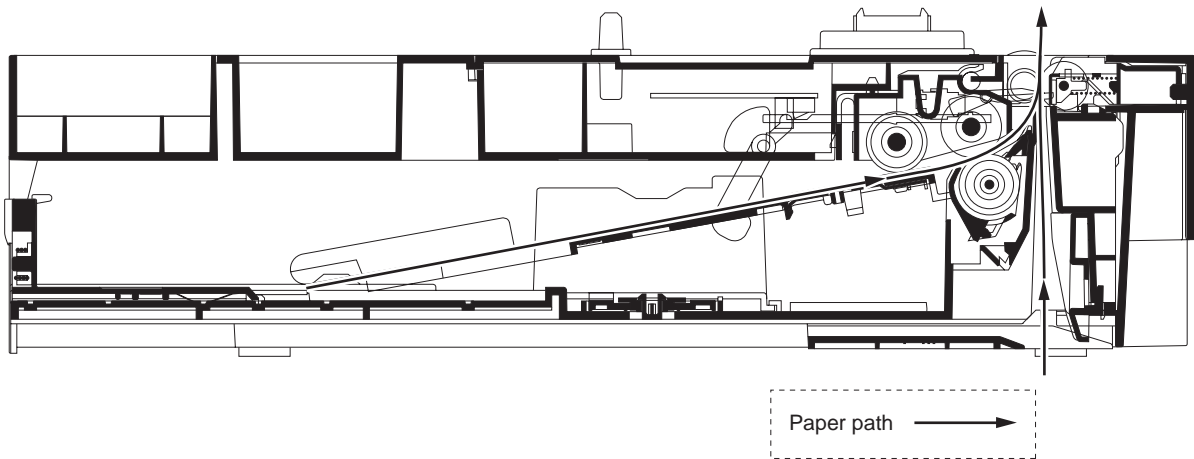

Figure 1-1-2

This page is intentionally left blank.

### **1-2-1 Installation environment**

#### **Installation location (Must comply with the same environment as the main unit installation.)**

Avoid direct sunlight or bright lighting. Ensure that the photo-conductor will not be exposed to direct sunlight or other strong light when removing paper jams.

Avoid locations subject to high temperature and high humidity or low temperature and low humidity; an abrupt change in the environmental temperature; and cool or hot, direct air.

Avoid places subject to dust and vibrations.

Choose a surface capable of supporting the weight of the machine.

Place the machine on a level surface (maximum allowance inclination: 1°).

Avoid air-borne substances that may adversely affect the machine or degrade the photo-conductor, such as mercury, acidic or alkaline vapors, inorganic gasses, NO<sub>x</sub>, SO<sub>x</sub> gases and chlorine-based organic solvents.

Select a well-ventilated location.

## 1-2-2 Unpacking

### (1) Unpacking

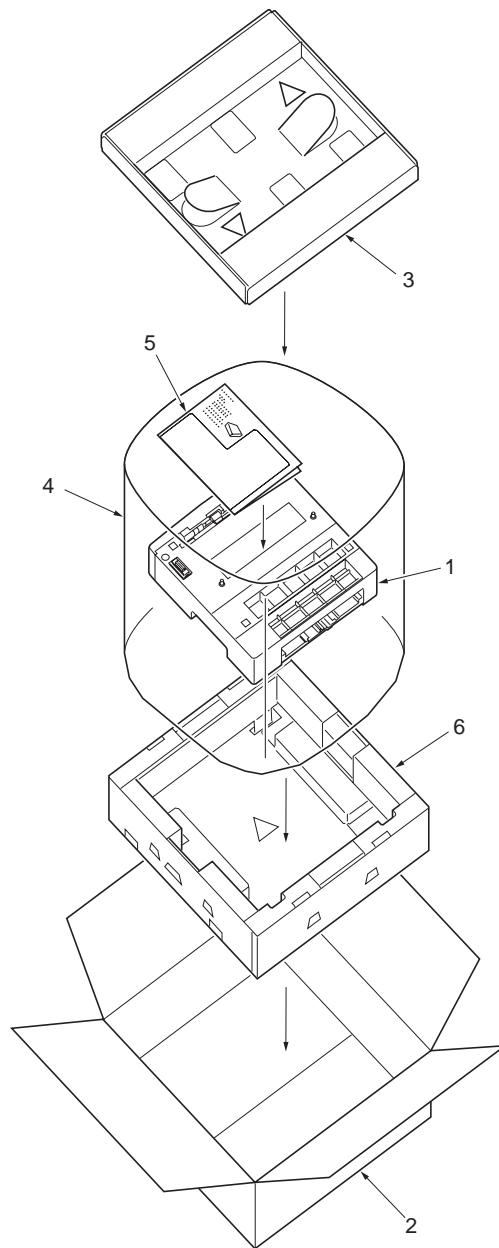

**Figure 1-2-1**

1. Paper feeder
2. Outer case
3. Top pad
4. Plastic sheet
5. Installation Guide
6. Front /rear pad assembly

Caution: Place the machine on a level surface. See the Installation Guide for installation.



**(2) Removing the cassette spacer****Procedure**

1. Pull the cassette out.
2. Remove the cassette spacer.
3. Push the cassette back in.

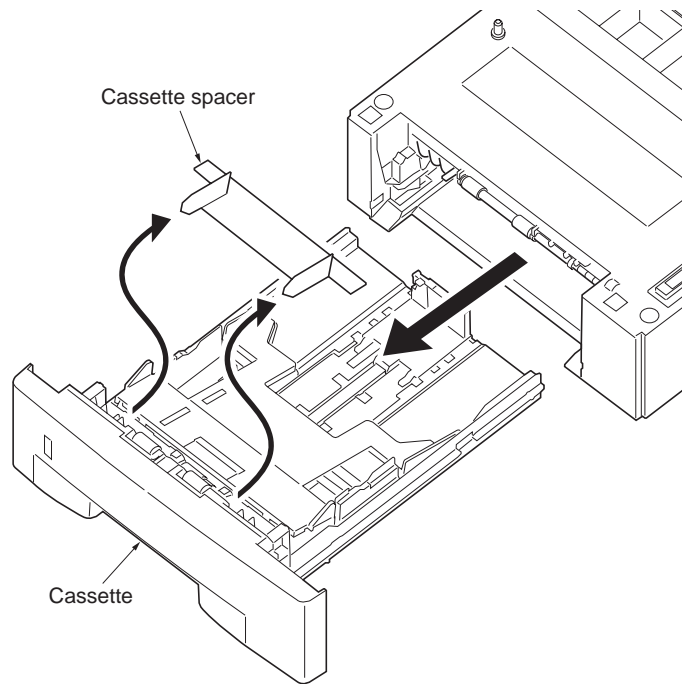
**Figure 1-2-2**

This page is intentionally left blank.

## 1-3-1 Paper misfeed detection

### (1) Paper misfeed indication

If paper jams in the paper feeder, the printer automatically goes offline, and the Jam indicator will flash rapidly. Status Monitor or COMMAND CENTER can indicate the location of the paper jam (the component where the paper jam has occurred). After removing the jammed paper, the printer will resume printing.

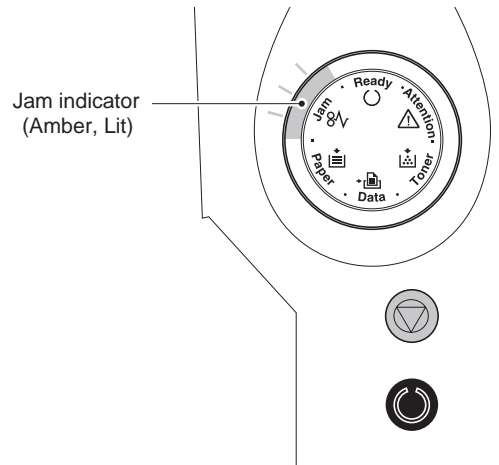
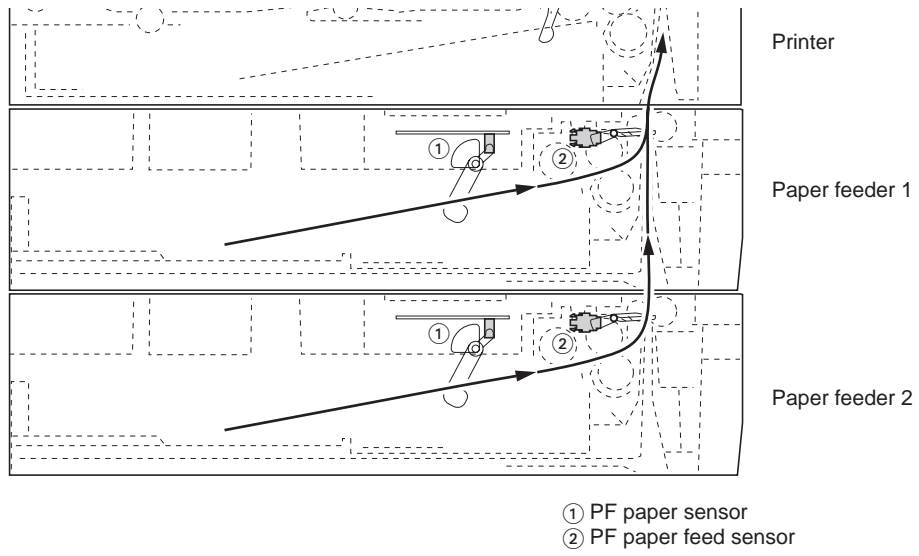

Figure 1-3-1

**(2) Paper misfeed detection**



**Figure 1-3-2**

## 1-3-2 Self-diagnostic function

### (1) Self-diagnostic function

The printer is equipped with self-diagnostic function which automatically halts the printer when an error is detected. The four indicators (Jam, Paper, Attention, Toner) are simultaneously lit, then indicate a specific error by the combination of the four indicators.

### (2) Self diagnostic codes indication

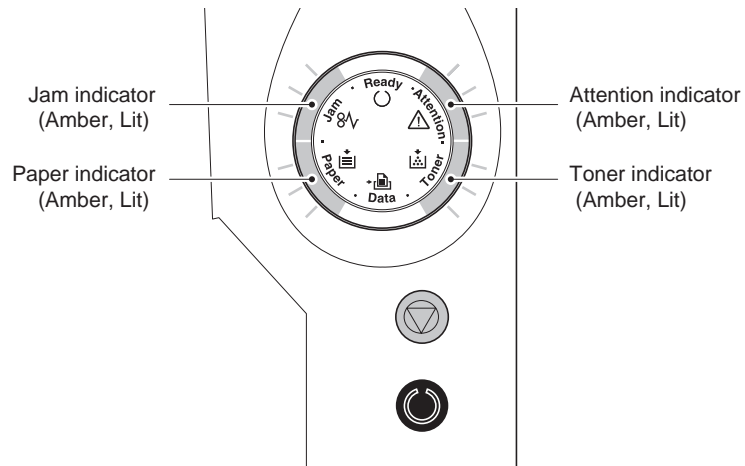
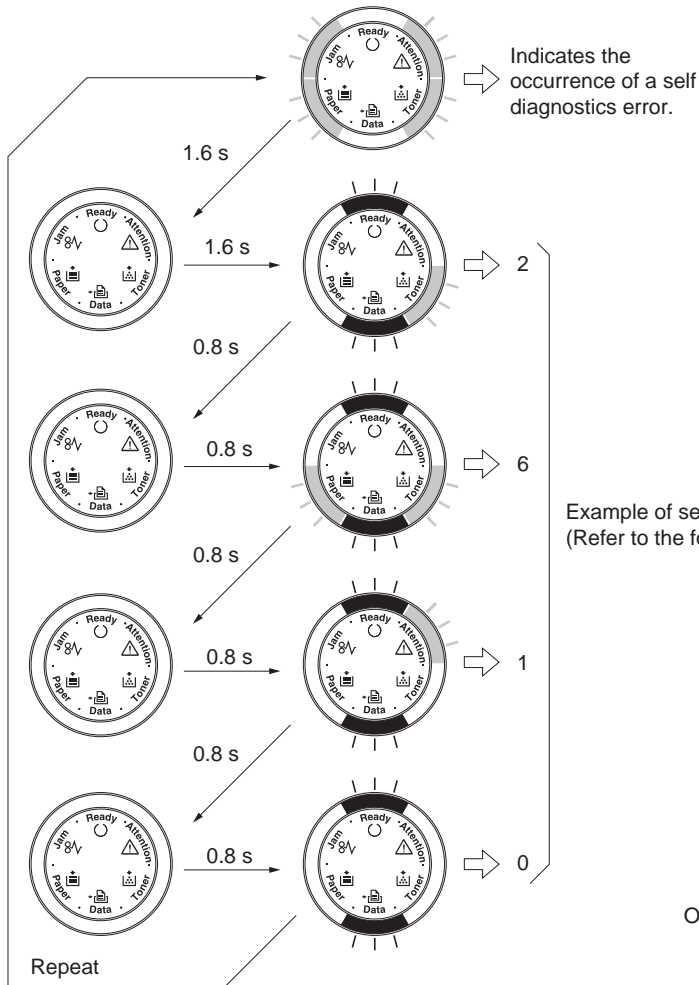

Figure 1-3-3

**Sequence of display**



Example of self-diagnostic code: 2610  
(Refer to the following code conversion table)

**Indication example**

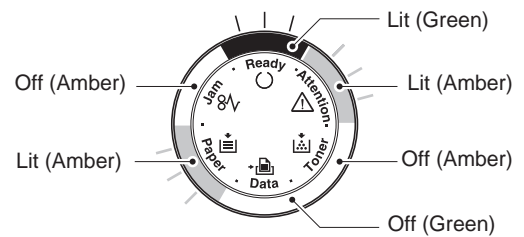

**Code conversion table**

Code	1	2	3	4	5	
Indicator						
Code	6	7	8	9	0	F
Indicator						

## (3) Self diagnostic codes

Code	Contents	Remarks	
		Causes	Check procedures/corrective measures
0420	<b>Paper feeder communication error</b> Communication error between printer's control PWB and paper feeder.	Improper installation paper feeder.	Follow installation instruction carefully again.
		Defective harness between paper feeder interface connector and control PWB (YC318), or improper connector insertion.	Reinsert the connector. Also check for continuity within the connector harness. If none, remedy or replace the harness (Refer to the service manual for the printer).
		Defective control PWB.	Replace the control PWB (Refer to the service manual for the printer).
		Defective harness between PF main PWB (YC5) and paper feeder interface connector, or improper connector insertion.	Reinsert the connector. Also check for continuity within the connector harness. If none, remedy or replace the harness (See page P.1-4-6).
		Defective PF mainPWB.	Replace the PF main PWB (See page P.1-4-6).
2610	<b>PF paper feed motor error (Paper feeder 1)</b> The PF paper feed motor of paper feeder 1 ready input is not given for 2 s during the PF paper feed motor is ON.	Defective harness between PF paper feed motor and PF main PWB (YC4), or improper connector insertion.	Reinsert the connector. Also check for continuity within the connector harness. If none, remedy or replace the harness (See page P.1-4-6).
		Defective PF paper feed motor drive transmission system.	Check if the gears rotate smoothly. If not, grease the bushings and gears. Check for broken gears and replace if any.
		Defective PF main motor.	Replace the PF main motor.
		Defective control PWB.	Replace the control PWB (Refer to the service manual for the printer).
2620	<b>PF paper feed motor error (Paper feeder 2)</b> The PF paper feed motor of paper feeder 2 ready input is not given for 2 s during the PF paper feed motor is ON.	Defective harness between PF paper feed motor and PF main PWB (YC4), or improper connector insertion.	Reinsert the connector. Also check for continuity within the connector harness. If none, remedy or replace the harness (See page P.1-4-6).
		Defective PF paper feed motor drive transmission system.	Check if the gears rotate smoothly. If not, grease the bushings and gears. Check for broken gears and replace if any.
		Defective PF main motor.	Replace the PF main motor.
		Defective control PWB.	Replace the control PWB (Refer to the service manual for the printer).

**1-3-3 Electric problems**

<b>Problem</b>	<b>Causes</b>	<b>Check procedures/corrective measures</b>
(1) Defective paper jam detecting.	Actuators of PF paper feed sensor does not operate smoothly.	Repair or replace.
	A piece of paper torn from a sheet is caught around actuator of PF paper feed sensor.	Check visually and remove it, if any.
	Defective PF paper feed sensor.	Replace the PF paper feed sensor.
	Defective PF main PWB.	Replace the PF main PWB (See page 1-4-6).
	Defective printer's control PWB.	Replace the control PWB (Refer to the service manual for the printer).



### 1-3-4 Mechanical problems

Problem	Causes/check procedures	Corrective measures
(1) No primary paper feed.	Check if the surfaces of the following rollers are dirty with paper powder: pickup roller and paper feed roller.	Clean with isopropyl alcohol.
	Check if the pickup roller and paper feed roller are deformed.	Check visually and replace any deformed rollers (See page 1-4-2).
	Defective installation position of drive unit.	Check visually and remedy if necessary.
	Defective PF paper feed motor.	Replace the PF paper feed motor.
	Defective installation position of retard roller spring.	Check visually and remedy if necessary.
(2) Skewed paper feed.	Check if the paper is curled.	Replace the paper.
	Misadjust the paper length guide or position of the width guides of the cassette.	Check visually and remedy if necessary.
(3) Multiple sheets of paper are fed at one time.	Check if the paper is excessively curled.	Replace the paper.
	Deformed retard roller.	Check visually and replace the retard roller assembly (retard roller) if it is deformed (See page 1-4-4).
(4) Paper jams.	Check if the contact between the pickup roller, paper feed roller and retard roller is correct.	Check visually and remedy if necessary.
(5) Abnormal noise is heard.	Check if the pulleys, rollers and gears operate smoothly.	Grease the bearings and gears.
	Check if the drive unit are installed correctly.	Check visually and remedy if necessary.

This page is intentionally left blank.

## **1-4-1 Precautions for assembly and disassembly**

### **(1) Precautions**

Be sure to turn the power switch of the machine off and disconnect the power plug before starting disassembly of the paper feeder.

When handling PWBs, do not touch connectors with bare hands or damage the PWB.

Do not touch any PWB containing ICs with bare hands or any object prone to static charge.

When removing the hook of the connector, be sure to release the hook.

Take care not to get the wire caught.

### 1-4-2 Paper feed section

#### (1) Detaching and refitting the middle roller/feed bracket assembly (paper feed roller and pickup roller)

##### Procedure

1. Remove the cassette from the paper feeder.

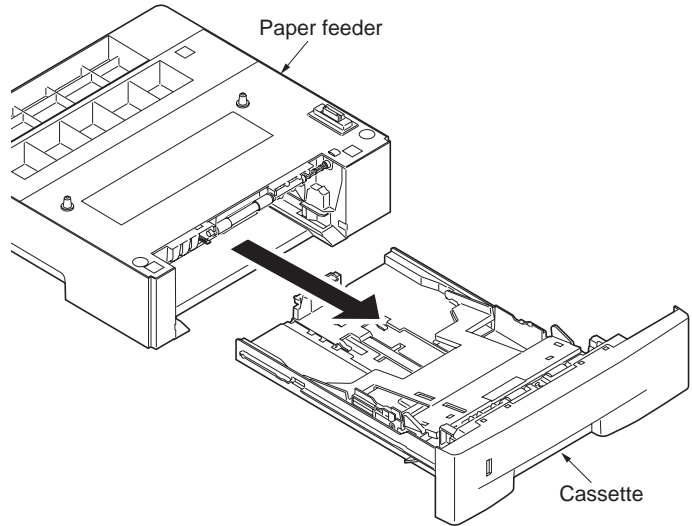

Figure 1-4-1

2. Remove the middle roller assembly from the middle C shaft and holders.
3. Remove two bearings from the middle roller.

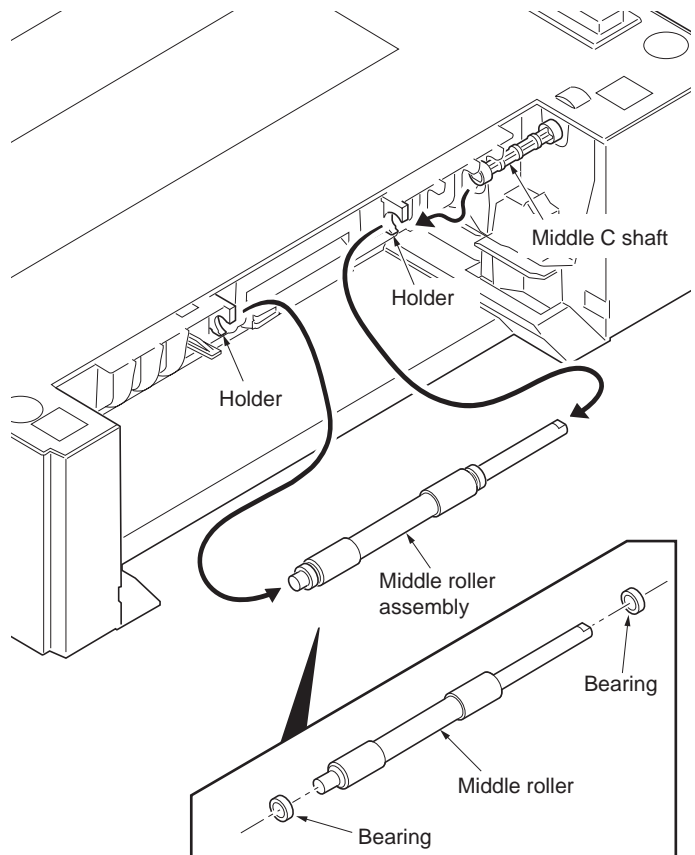
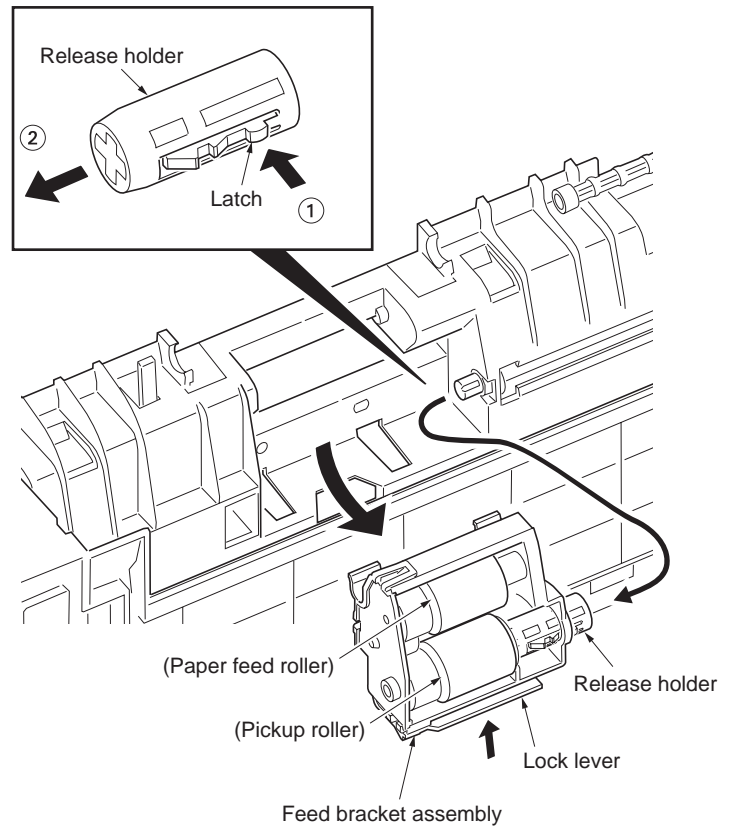

Figure 1-4-2

4. While pressing the latch and slide the release holder.
5. Push the lock lever and then remove the feed bracket assembly.
6. Check or replace the feed bracket assembly (paper feed roller and pickup roller) and refit all the removed parts.

**Figure 1-4-3**

**(2) Detaching and refitting the retard roller assembly (retard roller)****Procedure**

1. Remove the cassette from the paper feeder.
2. Push the cassette holder down until it locks.

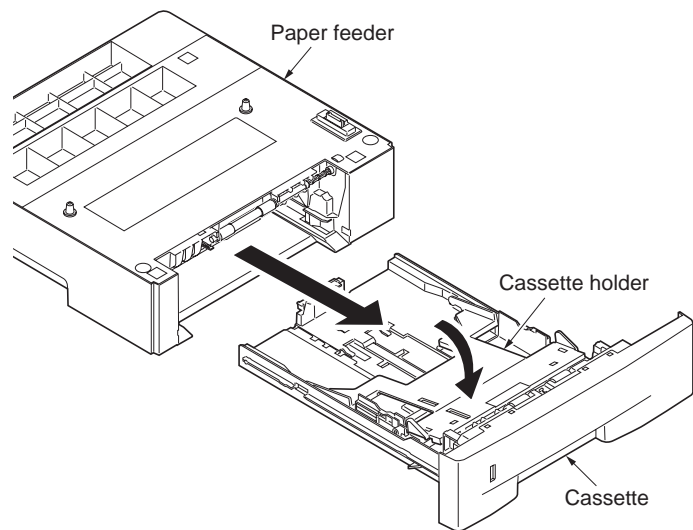
**Figure 1-4-4**

3. Unhook two hooks and then remove the retard guide.

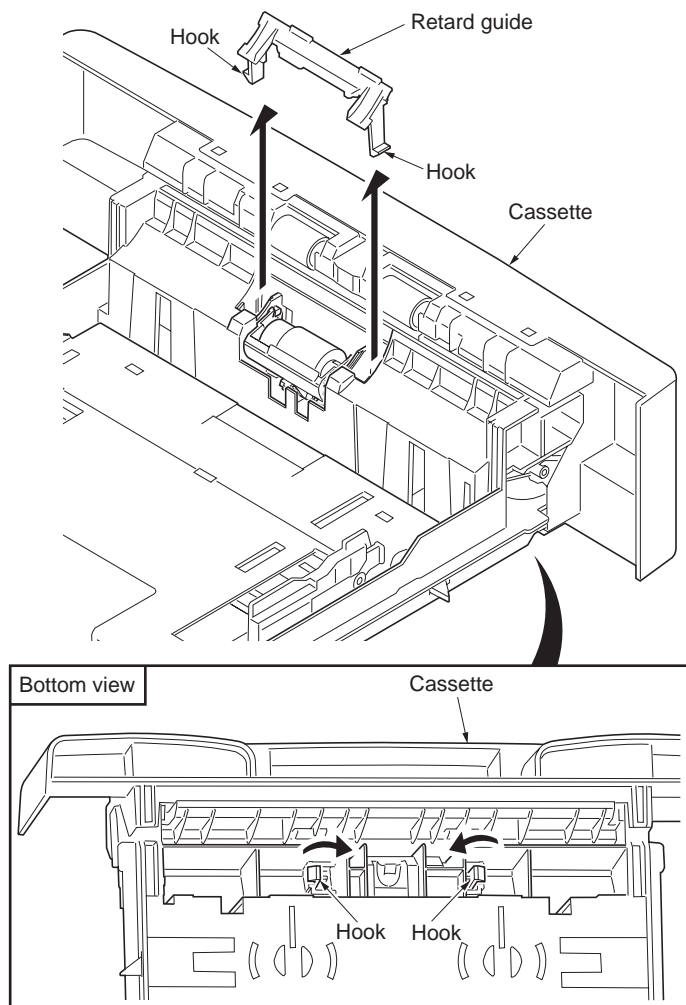
**Figure 1-4-5**

- 4. Remove the retard roller assembly from the projections.

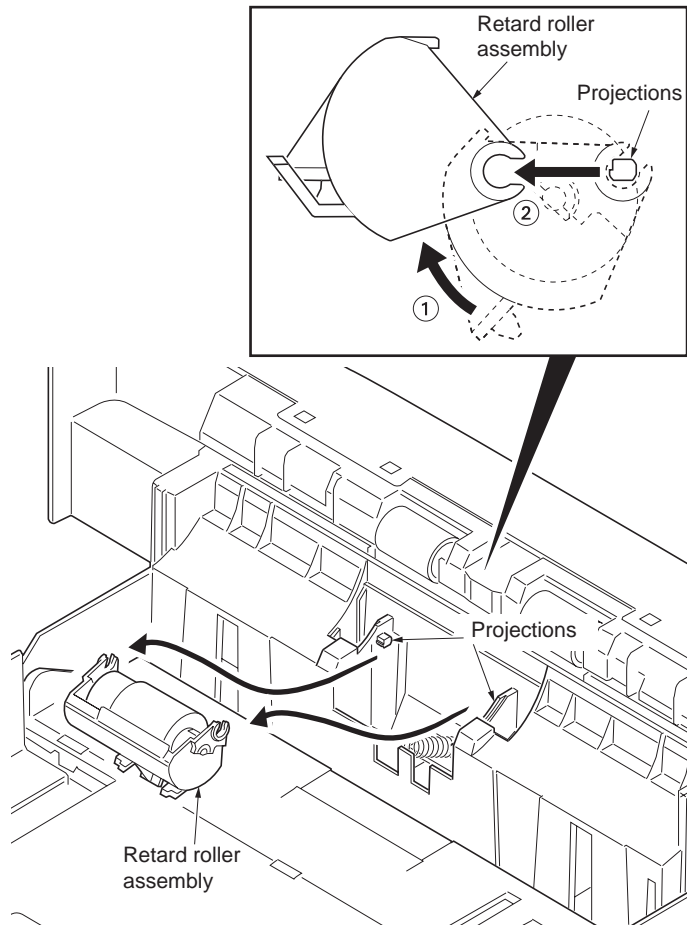

Figure 1-4-6

- 5. Check or replace the retard roller assembly (retard roller) and refit all the removed parts. Caution: Before refitting the retard roller assembly, firmly install the spring onto the projection of the retard roller assembly.

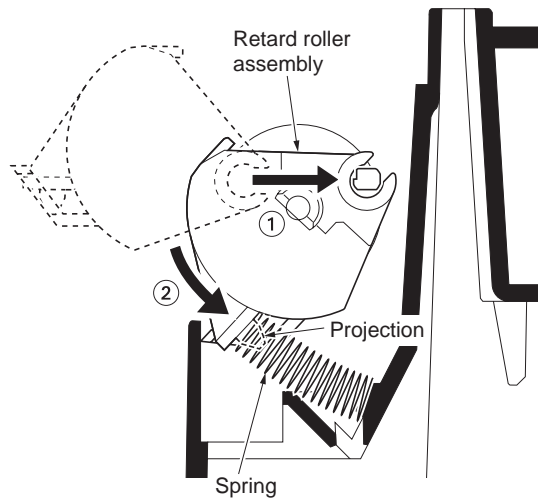

Figure 1-4-7

### 1-4-3 PWB

#### (1) Detaching and refitting the PF main PWB

##### Procedure

1. Remove the paper feeder from the printer.
2. Remove two screws and then remove the top cover.

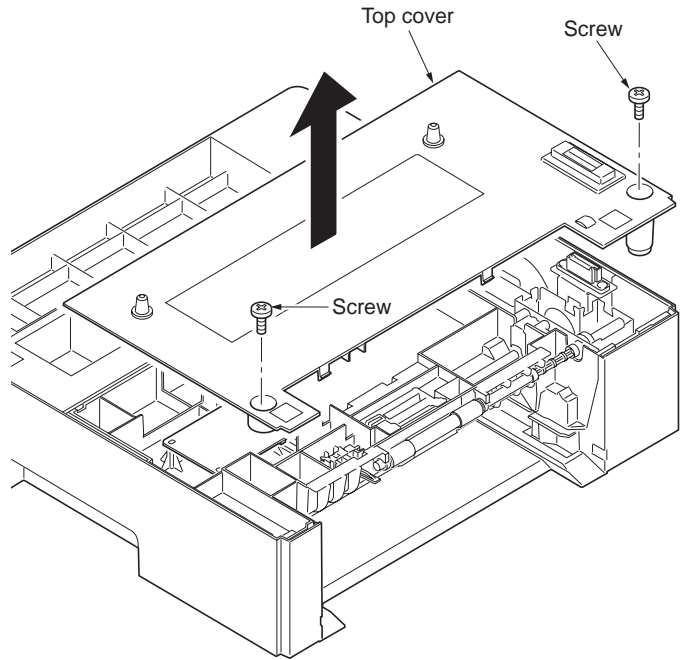

Figure 1-4-8

3. Remove two screws.
4. Remove the terminal of the ground wire.
5. Remove five connectors and then remove the PF main PWB.
6. Check or replace the PF main PWB and refit all the removed parts.

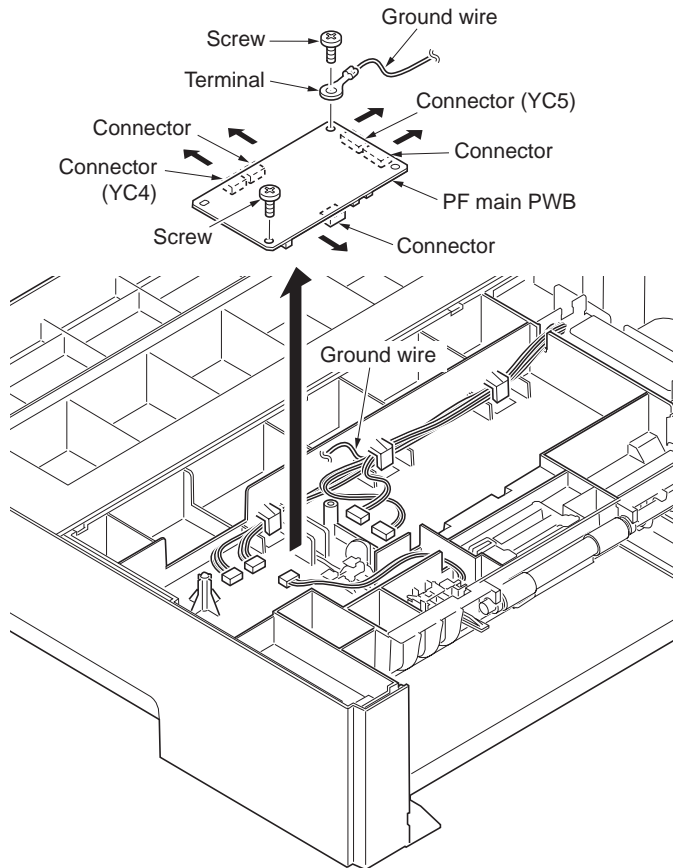

Figure 1-4-9



## 2-1-1 Paper feed section

### (1) Paper feed section

The paper feeder conveys paper from the cassette to the printer. Cassette can hold up to 250 sheets of paper. Paper is fed from the paper feeder by the rotation of the pickup roller and paper feed roller. The retard roller prevents multiple sheets from being fed at one time, via the torque limiter.

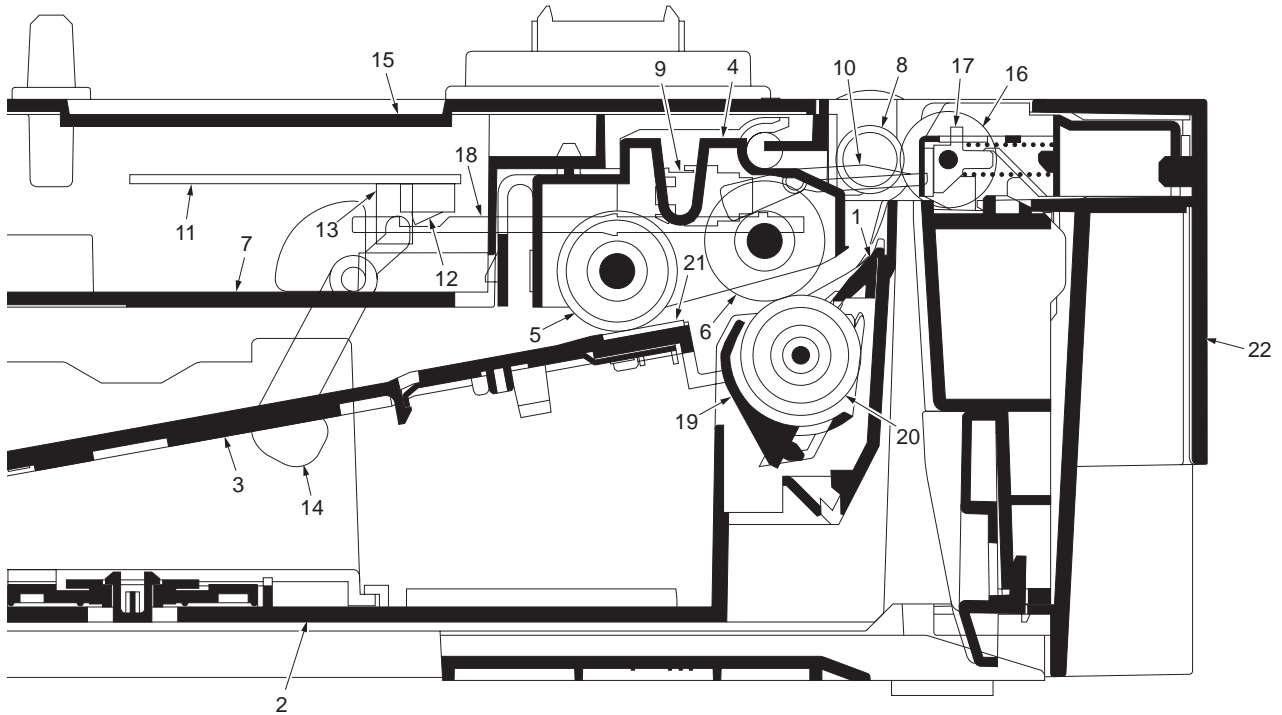

Figure 2-1-1 Paper feed section

- |                                      |                                 |
|--------------------------------------|---------------------------------|
| (1) Retard guide                     | (12) PF cassette switch         |
| (2) Cassette base                    | (13) PF paper sensor            |
| (3) Bottom plate                     | (14) Actuator (PF paper sensor) |
| (4) Feed bracket                     | (15) Top cover                  |
| (5) Pickup roller                    | (16) PF middle pulley           |
| (6) Paper feed roller                | (17) Cassette holder            |
| (7) Top frame                        | (18) Feeder pin                 |
| (8) Middle roller                    | (19) Retard holder              |
| (9) PF paper feed sensor             | (20) Retard roller              |
| (10) Actuator (PF paper feed sensor) | (21) Bottom pad                 |
| (11) PF main PWB                     | (22) Cassette cover             |

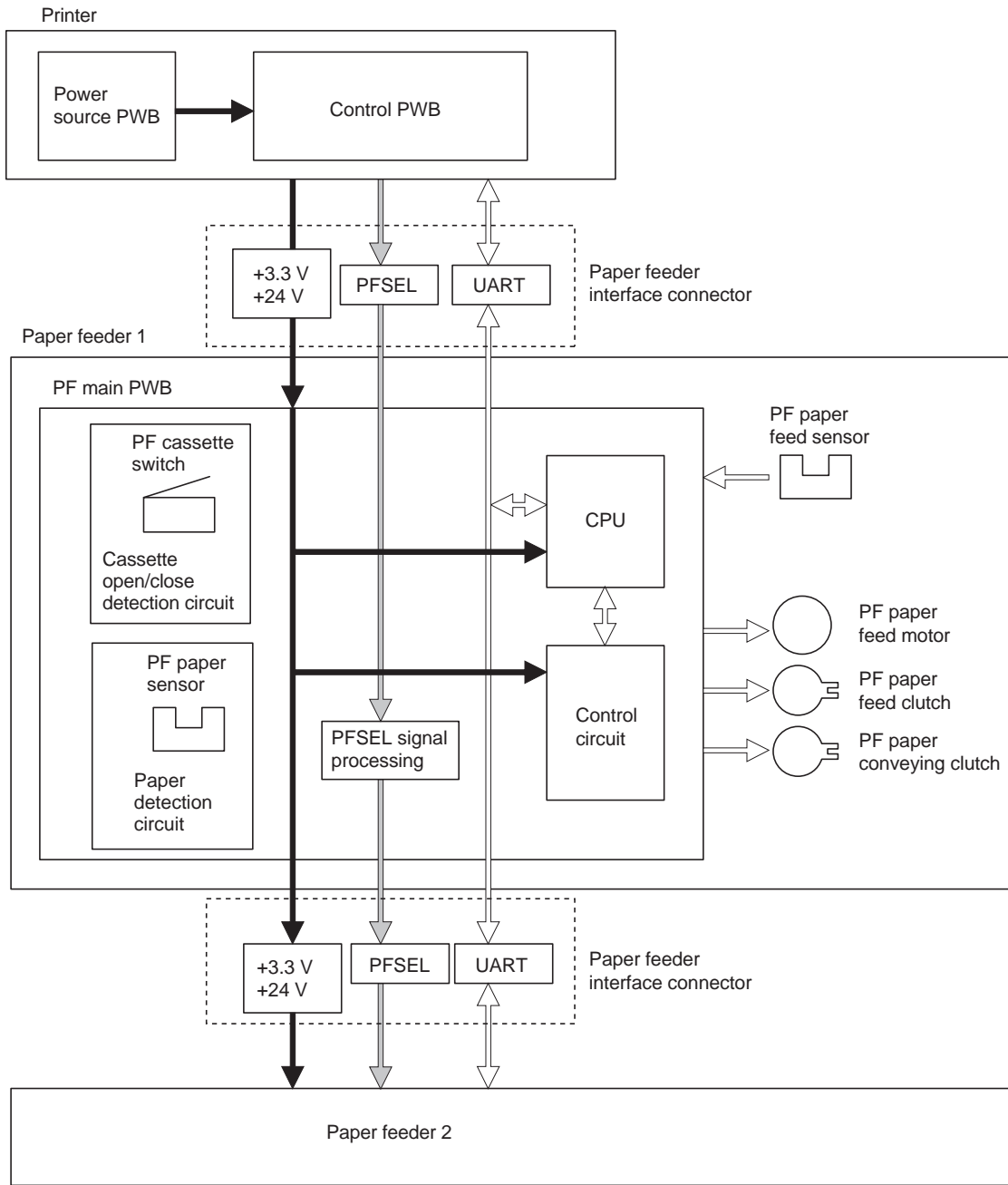
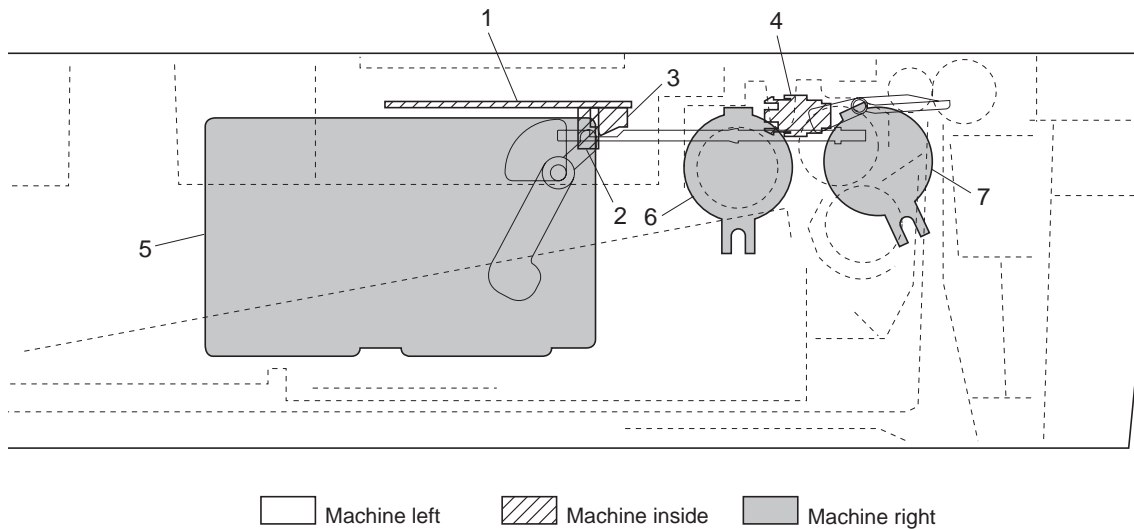

Figure 2-1-2 Paper feeder block diagram

## 2-2-1 Electrical parts layout

### (1) Electrical parts layout



**Figure 2-2-1 Electrical parts layout**

- |    |                                |  |
|----|--------------------------------|--|
| 1. | PF main PWB .....              | Controls electrical components in the paper feeder and serial communications with the printer. |
| 2. | PF paper sensor .....          | Detects the presence of paper in the cassette.   |
| 3. | PF cassette switch .....       | Detects the existence of the cassette.   |
| 4. | PF paper feed sensor .....     | Detects paper jam in the paper feeder.   |
| 5. | PF paper feed motor .....      | Drives the paper feed mechanism in the paper feeder.   |
| 6. | PF paper feed clutch .....     | Controls the drive of the paper feed roller.   |
| 7. | PF paper conveying clutch..... | Controls the drive of the middle roller.   |

This page is intentionally left blank.

2-3-1 PF main PWB

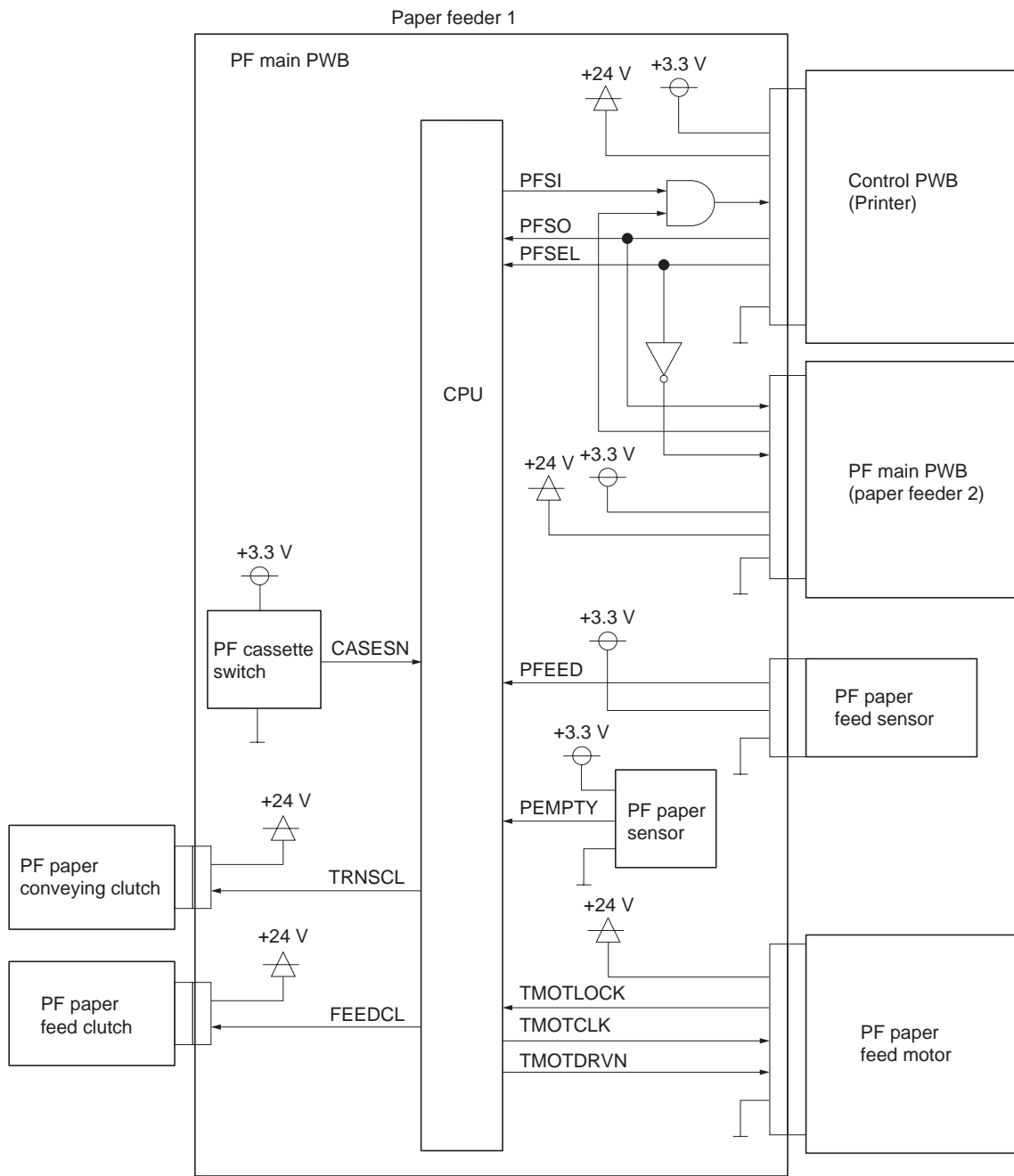

Figure 2-3-1 PF main PWB block diagram

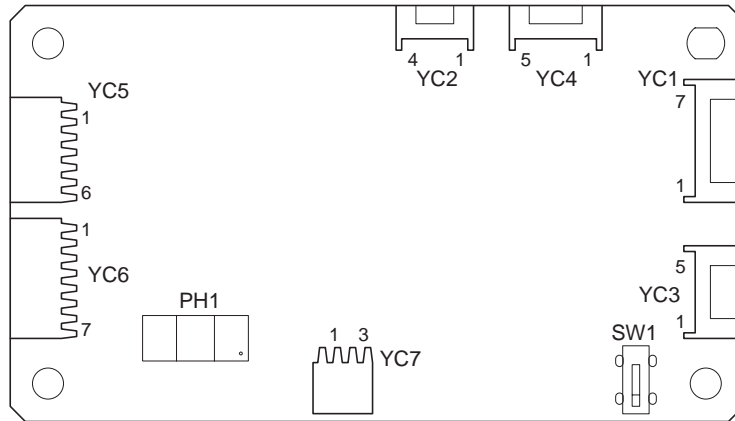
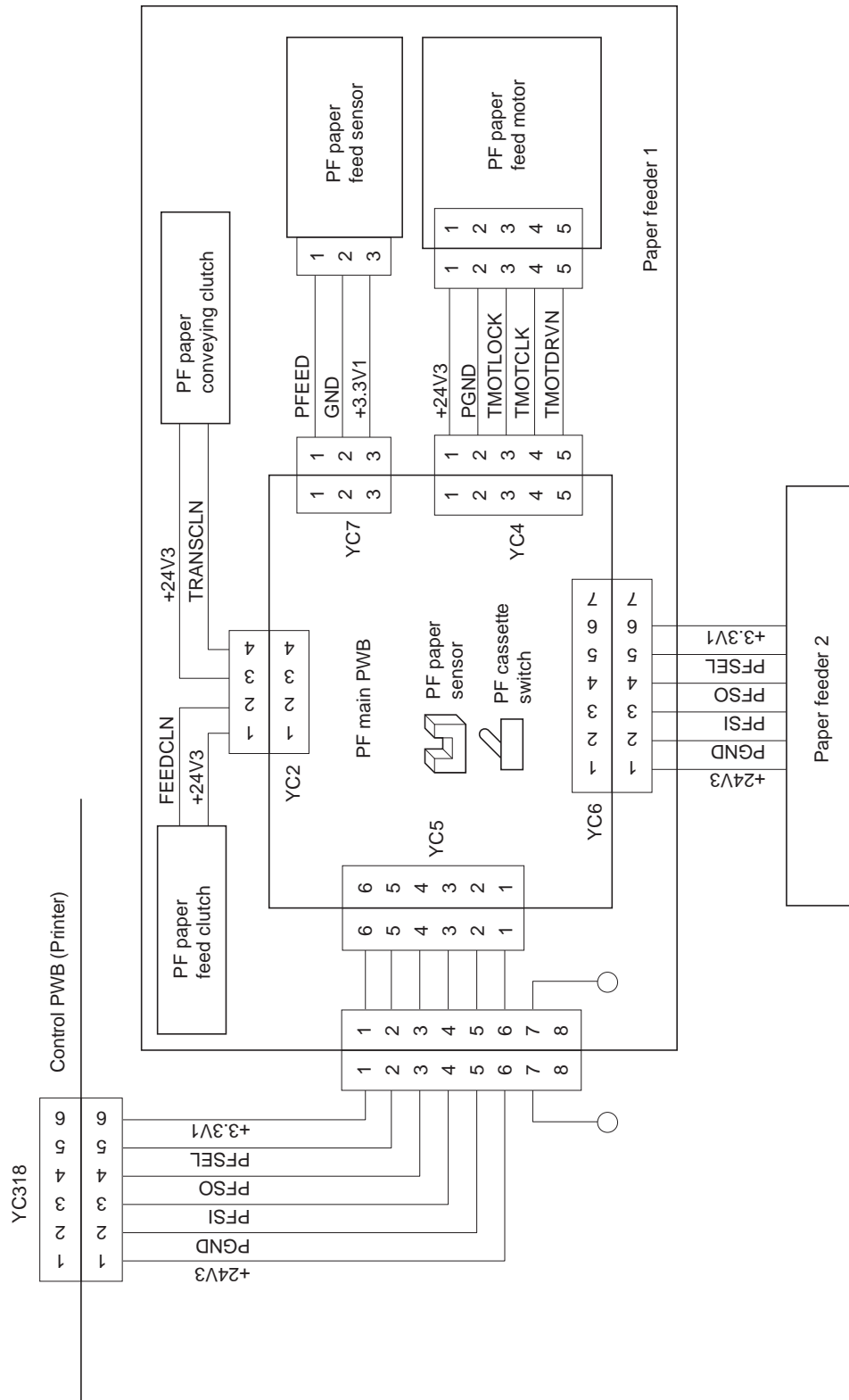

Figure 2-3-2 PF main PWB silk-screen diagram

Connector	Pin	Signal	I/O	Voltage	Description
YC2 Connected to the PF paper feed clutch and PF paper conveying clutch	1	+24V3	O	24 V DC	24 V DC power source
	2	FEEDCLN	O	0/24 V DC	PF paper feed clutch: On/Off
	3	+24V3	O	24 V DC	24 V DC power source
	4	TRANSCLN	O	0/24 V DC	PF paper conveying clutch: On/Off
YC4 Connected to the PF paper feed motor	1	+24V3	O	24 V DC	24 V DC power source
	2	GND	-	-	Ground
	3	TMOTLOCK	I	0/3.3 V DC	PF paper feed motor lock signal
	4	TMOTCLK	O	0/3.3 V DC (pulse)	PF paper feed motor drive clock signal
	5	TMOTDRVN	O	0/24 V DC	PF paper feed motor: On/Off
YC5 Connected to the control PWB (printer) or PF main PWB (paper feeder 1)	1	+24V3	I	24 V DC	24 V DC power source
	2	GND	-	-	Ground
	3	PFSI	I	0/3.3 V DC (pulse)	Serial communication data input signal
	4	PFSO	O	0/3.3 V DC (pulse)	Serial communication data output signal
	5	PFSEL	I	0/3.3 V DC (pulse)	Paper feeder selection signal
	6	+3.3V1	I	3.3 V DC	3.3 V DC power source
YC6 Connected to the PF main PWB (paper feeder 2)	1	+24V3	O	24 V DC	24 V DC power source
	2	PGND	-	-	Ground
	3	PFSI	O	0/3.3 V DC (pulse)	Paper feeder 2 serial communication data input signal
	4	PFSO	I	0/3.3 V DC (pulse)	Paper feeder 2 serial communication data output signal
	5	PFSEL	I	0/3.3 V DC (pulse)	Paper feeder selection signal
	6	+3.3V1	I	3.3 V DC	3.3 V DC power source
	7	NC	-	-	Not used
YC7 Connected to the PF paper feed sensor	1	PFEED	I	0/3.3 V DC	PF paper feed switch: On/Off
	2	GND	-	-	Ground
	3	+3.3V1	O	3.3 V DC	3.3 V DC power source

2-4-1 Appendixes

(1) Wiring diagram



This page is intentionally left blank.



## **KYOCERA MITA EUROPE B.V.**

Hoeksteen 40, 2132 MS Hoofddorp,  
The Netherlands  
Phone: +31.20.654.0000  
Home page: <http://www.kyoceramita-europe.com>  
Email: [info@kyoceramita-europe.com](mailto:info@kyoceramita-europe.com)

**KYOCERA MITA NEDERLAND B.V.**  
Beechavenue 25, 1119RA Schiphol-Rijk  
The Netherlands  
Phone: +31.20.58.77.200

**KYOCERA MITA (UK) LTD**  
8 Beacontree Plaza  
Gillette Way Reading Berks RG2 OBS,  
U.K.  
Phone: +44.1189.311.500

**KYOCERA MITA ITALIA S.p.A.**  
Via G. Verdi, 89 / 91, 20063 Cernusco s/N  
Milano, Italy  
Phone: +39.02.92179.1

**S.A. KYOCERA MITA BELGIUM N.V.**  
Hermesstraat 8A, 1930 Zaventem,  
Belgium  
Phone: +32.2.720.9270

**KYOCERA MITA FRANCE S.A.**  
Parc Les Algorithmes Saint Aubin  
91194 GIF-SUR-YVETTE,  
France  
Phone: +33.1.6985.2600

**KYOCERA MITA ESPAÑA S.A.**  
Edificio Kyocera, Avda de Manacor No. 2,  
28290 Las Matas (Madrid),  
Spain  
Phone: +34.91.631.8392

**KYOCERA MITA FINLAND OY**  
Kirvesmiehenkatu 4, 00880 Helsinki,  
Finland  
Phone: +358.9.4780.5200

**KYOCERA MITA (SCHWEIZ)**  
Hohlstrasse 614, 8048 Zürich  
Switzerland  
Phone: +41.1.908.4949

**KYOCERA MITA DEUTSCHLAND GMBH**  
Otto-Hahn-Str. 12 D-40670 Meerbusch,  
Germany  
Phone: +49.2159.918.0

**KYOCERA MITA GMBH AUSTRIA**  
Eduard-Kittenberger-Gasse 95,  
1230 Wien,  
Austria  
Phone: +43.1.86338.210

**KYOCERA MITA SVENSKA AB**  
Esbogatan 16B 164 75 Kista,  
Sweden  
Phone: +46.8.546.55000

**KYOCERA MITA NORGE**  
Postboks 150 Oppsal, NO 0619 Oslo  
Olaf Helsetsvai 6, NO 0694 Oslo,  
Norway  
Phone: +47.22.62.73.00

**KYOCERA MITA DANMARK A/S**  
Ejby Industrivej 1, DK-2600 Glostrup,  
Denmark  
Phone: +45.5687.1100

**KYOCERA MITA PORTUGAL LDA.**  
Rua do Centro Cultural, 41 (Alvalade) 1700-106 Lisbon,  
Portugal  
Phone: +351.21.842.9100

**KYOCERA MITA SOUTH AFRICA (PTY) LTD.**  
527 Kyalami Boulevard,  
Kyalami Business Park Midrand,  
South Africa  
Phone: +27.(0)11.540.2600

## **KYOCERA MITA AMERICA, INC.**

**Headquarters:**  
225 Sand Road,  
Fairfield, New Jersey 07004-0008,  
U.S.A.  
Phone: (973) 808-8444

**KYOCERA MITA AUSTRALIA PTY. LTD.**  
Level 3, 6-10 Talavera Road, North Ryde,  
N.S.W. 2113 Australia  
Phone: (02) 9888-9999

**KYOCERA MITA NEW ZEALAND LTD.**  
1-3 Parkhead Place, Albany  
P.O. Box 302 125 NHPC, Auckland,  
New Zealand  
Phone: (09) 415-4517

**KYOCERA MITA (THAILAND) CORP., LTD.**  
9/209 Ratchada-Prachachem Road,  
Bang Sue, Bangkok 10800, Thailand  
Phone: (02) 586-0320

**KYOCERA MITA SINGAPORE PTE LTD.**  
121 Genting Lane, 3rd Level,  
Singapore 349572  
Phone: 67418733

**KYOCERA MITA HONG KONG LIMITED**  
11/F., Mita Centre,  
552-566, Castle Peak Road,  
Tsuen Wan, New Territories,  
Hong Kong  
Phone: 24297422

**KYOCERA MITA TAIWAN Corporation.**  
7F-1~2, No.41, Lane 221, Gangchi Rd.  
Neihu District, Taipei, Taiwan, 114. R.O.C.  
Phone: (02) 87511560

## **KYOCERA MITA Corporation**

2-28, 1-chome, Tamatsukuri, Chuo-ku  
Osaka 540-8585, Japan  
Phone: (06) 6764-3555  
<http://www.kyoceramita.com>

## KYOCERA MITA AMERICA, INC.

### **Headquarters:**

225 Sand Road,  
Fairfield, New Jersey 07004-0008  
TEL : (973) 808-8444  
FAX : (973) 882-6000

### **New York Branch:**

1410 Broadway 23rd floor  
New York, NY 10018  
TEL : (917) 286-5400  
FAX : (917) 286-5402

### **Northeastern Region:**

225 Sand Road,  
Fairfield, New Jersey 07004-0008  
TEL : (973) 808-8444  
FAX : (973) 882-4401

### **Midwestern Region:**

201 Hansen Court Suite 119  
Wood Dale, Illinois 60191  
TEL : (630) 238-9982  
FAX : (630) 238-9487

### **Western Region:**

14101 Alton Parkway,  
Irvine, California 92618-7006  
TEL : (949) 457-9000  
FAX : (949) 457-9119

### **Southeastern Region:**

1500 Oakbrook Drive,  
Norcross, Georgia 30093  
TEL : (770) 729-9786  
FAX : (770) 729-9873

### **Southwestern Region:**

2825 West Story Road,  
Irving, Texas 75038-5299  
TEL : (972) 550-8987  
FAX : (972) 252-9786

### **National Operation Center & National Training Center:**

2825 West Story Road,  
Irving, Texas 75038-5299  
TEL : (972) 659-0055  
FAX : (972) 570-5816

### **Latin America Division:**

8240 N.W. 52nd. Terrace Dawson Building,  
Suite 108 Miami, Florida 33166  
TEL : (305) 421-6640  
FAX : (305) 421-6666

## KYOCERA MITA CANADA, LTD.

6120 Kestrel Road, Mississauga,  
Ontario L5T 1S8, Canada  
TEL : (905) 670-4425  
FAX : (905) 670-8116

## KYOCERA MITA MEXICO, S.A. DE C.V.

Av. 16 de Septiembre #407  
Col. Santa Inés,  
Azcapotzalco México,  
D.F. 02130, México  
TEL : (55) 5383-2741  
FAX : (55) 5383-7804

©2008 KYOCERA MITA Corporation

<http://www.kyoceramita.com>

 **KYOCERA** is a trademark of Kyocera Corporation

Printed in U.S.A.